



10.4 inch LCD color
ECHO SOUNDER

ES-1080

OPERATION MANUAL

SUZUKI FISH FINDER CO., LTD.

HEAD OFFICE: 12-1 MAMIZUKACHO, TOYOHASHI, AICHI, 441-8007 JAPAN

PHONE: (81) 532-32-7511 FAX: (81) 532-32-7500
e mail address: sales@suzukiff.co.jp URL: <http://www.suzukiff.co.jp/>

CONTENTS

Chapter 1	INTRODUCTION	2
	BEFORE OPERATION	3
	FOR YOUR SAFETY	5
	SUPPLIED COMPONENTS	7
	INSTALLATION	8
	CONTROL PANEL	11
	MODE EXAMPLE	12
Chapter 2	INITIAL SETTINGS	13
	INITIAL SETTINGS	14
Chapter 3	FUNCTION SETTINGS	17
	MENU 1	19
	MENU 2	21
Chapter 4	FUNCTION DIALS and KEYS	59
	DIAL OPERATION	60
	KEY OPERATION	68
	AUTO RANGE / AUTO SHIFT	74
	SPECIFICATIONS	75

Chapter 1

INTRODUCTION

Thank you for purchasing the ES-1080.

This operation manual provides complete information on safely operating **the COLOR LCD ECHO SOUNDER MODEL ES-1080** to its full potential.

Before operating this equipment, please read this manual thoroughly to understand the operation to avoid any trouble and possible injury in advance.

BEFORE OPERATION	SYMBOLS -----	3
	CAUTION NOTE -----	3
	POWER ON/OFF -----	4
	KEY OPERATION -----	4
	TFT LCD -----	4
FOR YOUR SAFETY	ENVIRONMENTAL -----	5
	CONDITIONS	
	CONVENIENT LOCATION -----	5
	POWER REQUIREMENTS -----	6
	HANDLING -----	6
SUPPLIED COMPONENTS	COMPOSITION -----	7
INSTALLATION	DIMENSIONS -----	8
	CONNECTIONS to REAR PANEL -----	8
	MAIN UNIT MOUNTING -----	9
	ELECTRICAL CONNECTIONS -----	10
CONTROL PANEL -----		11
MODE EXAMPLE	DISPLAY -----	12

BEFORE OPERATION

SYMBOLS

The following conventions are used in this manual.

Before using this unit, make sure to understand the following, which are used throughout this manual.



: indicates an imminently hazardous situation which, if not avoided, will result in death or serious injury.



: indicates a potentially hazardous situation which, if not avoided, will result in death or serious injury.



: indicates precautionary measures to avoid potential problems.

NOTE !

: indicates contents for the user's reference.

cf

: see the page.

CAUTION NOTE

This manual contains important information about the ES-1080.

In order to fully understand the operation, and know detailed information for your safety, please read this manual carefully.

Keep this operation manual in a safe place where it is easy to find.



When you give this unit to someone else, make sure to give this manual, too.

Any use other than that mentioned in this manual is not guaranteed.

The contents in this manual are subject to change without notice or obligation.

Please contact us if you should have any questions regarding the use of this equipment.

POWER ON/OFF

Press and hold the  key to turn on the power. After one beep the echo sounder display appears on the screen. Hold the  key to turn the power off.

KEY OPERATION

One beep will advise you when a right function is performed.

Three beeps will advise you when a wrong operation or a wrong key is pressed.

TFT LCD

The high quality TFT (Thin Film Transistor) LCD displays 99.99% of its picture elements. The remaining 0.01% may drop out or light, however this is an inherent property of the LCD. It is not a sign of malfunction.

ENVIRONMENTAL CONDITIONS



Keep the unit away from flammable gas.
It will cause fire.



Pay attention to the following environmental conditions on mounting, otherwise the unit may become heated causing trouble and malfunction.

- It is recommended that it will be mounted in a location which provides protection from spray or heavy vibration.
 - Do not bring any other heated object close to the equipment.
 - Do not bring any magnetic object close to the equipment.
-

CONVENIENT LOCATION



Find a convenient location. The ES-1080 may be mounted upright on any level surface and tighten securely.

Make sure the following on wiring. Otherwise damage or fire may occur.

- Take care of connecting the cables not to be disturbed the operation.
 - Do not use the cables bent, twisted or stretched by force.
 - Do not put heavy objects on the cables.
-



When removing/plugging in cables, make sure to turn the power off.
Never pull cables, otherwise it may damage the unit and result in fire or electrical shock.

POWER REQUIREMENTS



Operating voltage: 10.5 to 40 volts DC

Please use correct voltage, otherwise, it will lead to fire or electric shock, or damage to the unit.



Make sure to turn off the power by the power "ON/OFF" keys on the control panel. Turning on/off the power by the ships switchboard may damage the unit or cause problems with operations. When starting the vessels engine, make sure the power of this unit is turned off, otherwise it may cause problems with the unit.

HANDLING



Do not operate this unit while steering.

It could result in collision and serious injury or damage.

Do not open the main unit case. Otherwise electrical shock, damage, and serious bodily injury to user may result. For inspection/adjustment/parts installation/repair, please ask your dealer. There is a high voltage component inside, and it will result in electric shock.

The sufficient reinforcement and water tightness should be make when installing the transducer.

It could result in collision and serious injury or damage.



Please use the specified fuse.

If not, it could result in malfunction and / or fire.

Please use the specified power supply cable cords.

Using cables other than those specified could generate heat an



When replacing batteries,

- Insert new batteries. Be sure that the polarity (+ , -) is correct.
- Never subject batteries to very hot or cold temperatures, or disassemble or dump into fire/water.
- Never use batteries with fluid leaking out.

SUPPLIED COMPONENTS

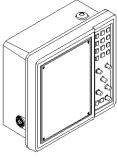
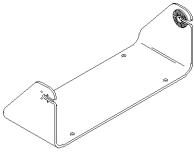
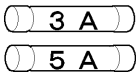
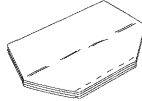
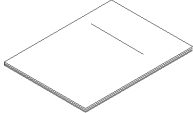
COMPOSITION

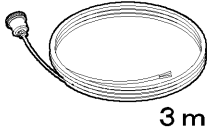
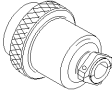
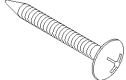
CODE	* * N A 1 1 0		* * N A 1 2 1		
ITEM	<u>MAIN UNIT</u> 	<u>BRACKET</u> 	<u>POWER FUSE</u> 	<u>UNIT COVER</u> 	<u>O. MANUAL</u> 
PARTS#	—	35275C	—	2035-COV	1080-OPM-E
QTY	1	1	EACH 3	1	1

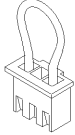
CODE	* * N A 0 1 0				* * N A 1 2 1
ITEM	<u>POWER SUPPLY CABLE</u>  3 m	<u>TD PLUG</u> 	<u>TAPPING SCREW</u> 	<u>HEX.BOLT</u> 	<u>JUMPER PLUG</u> 
PARTS#	33282D	HS21P-3	M 6 x 20	M 8 x 20 with washer	WJ-602
QTY	1	1	4	2	1

- NOTE :
- 1) The code number is shown on the packages. However * * indicates the lot management number.
 - 2) Transducers and TD related parts are shipped only when required.

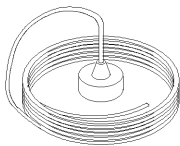

- 3) * * NA121 - JUMPER PLUG is included only when the unit ES-1080FFS is shipped.

INSTALLATION

DIMENSIONS

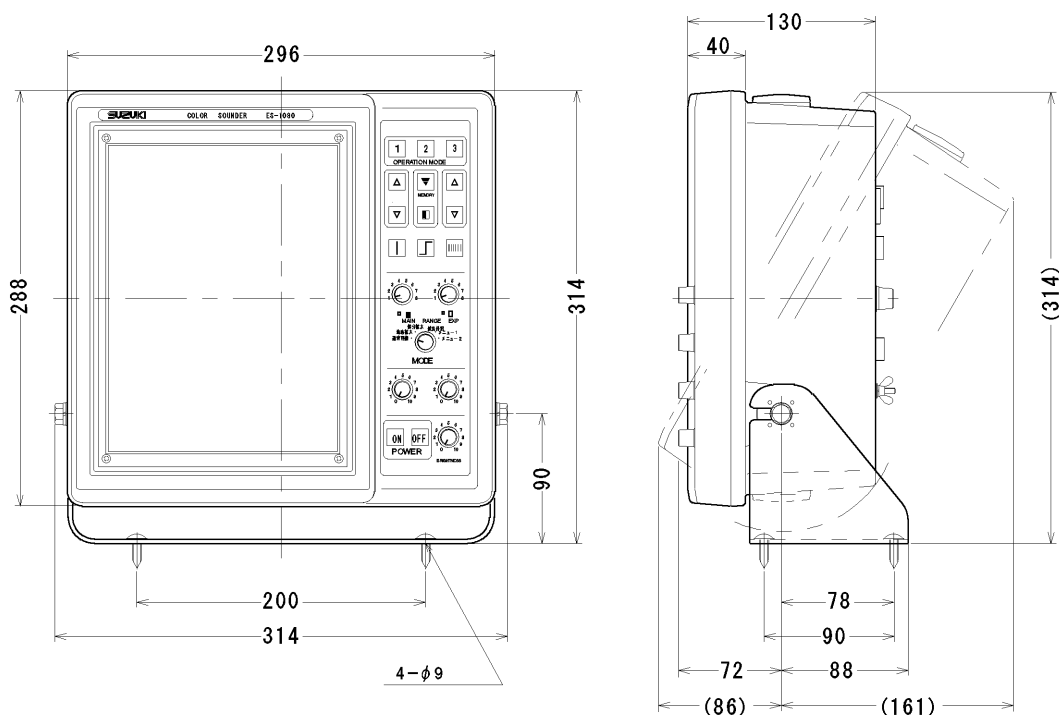

CONNECTIONS to REAR PANEL

TEMPERATURE SENSOR SIGNAL INPUT

-To be connected to an optional temperature sensor OP-102 or OP-41-1.

3 PIN TRANSDUCER TERMINAL

-To be connected to the transducer

FUSE HOLDER

-Use the correctly-rated fuse specified below.

POWER SUPPLY FUSE RATING

POWER SUPPLY	FUSE RATING
12V.....	5A
24V.....	3A
32V.....	3A

EARTH TERMINAL

-To be connected to a GND point.

NAVIGATOR INTERFACE

-NMEA-0183 data input or to be connected to a navigator.

EXTERNAL SOUNDER INTERFACE (IN/OUT terminal)

-To be connected to an external sounder.

NMEA-0183 DATA OUTPUT

-NMEA-0183 data (depth and water temp.) output to an external equipment.

POWER SUPPLY TERMINAL

-The power supply voltage range from 10.5 to 40 volts DC.

MAIN UNIT MOUNTING

- 1) Using the attached tapping screws (4 pcs), secure the mounting bracket to the site selected.
- 2) Screw the hexagonal bolts (M8 x 20 with washer) temporarily to the notches of the mounting bracket.
- 3) Insert the main unit and select a comfortable viewing angle.
Tighten the hexagonal bolts.

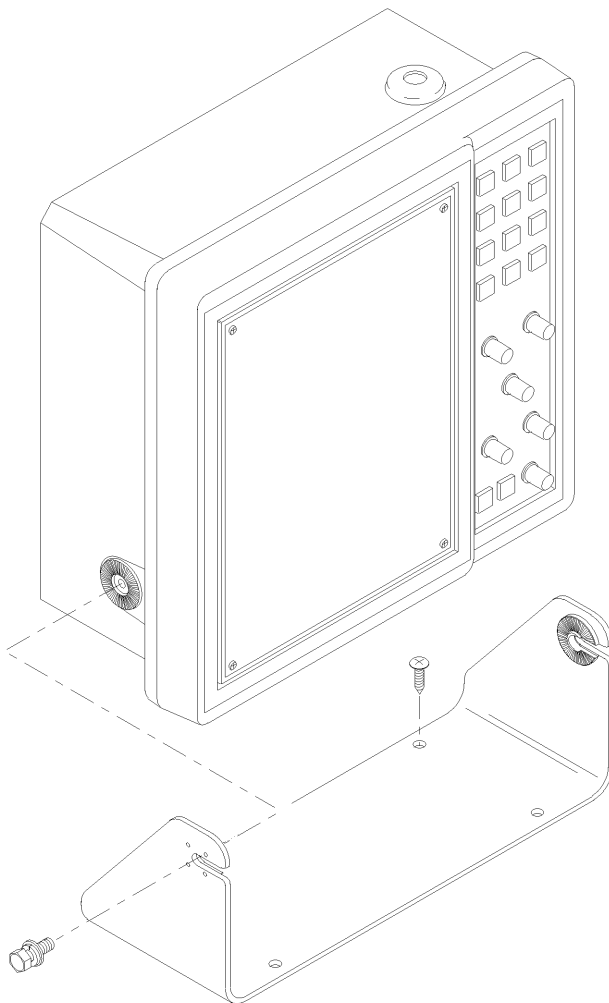

The unit should be installed on a flat surface.
Do not use the unit while tentatively installed, otherwise it may cause trouble.



For long term trouble-free service, the proposed site for installation should be free as much as possible from shocks and engine vibrations and away from salt spray, heat sources and direct sunlight.

ELECTRICAL CONNECTIONS

NMEA -INTERFACE (6 pins)

PIN No.	CONNECTION
No. 1	NC
No. 2	NC
No. 3	SHIELD
No. 4	SIGNAL OUTPUT +
No. 5	SIGNAL OUTPUT -
No. 6	NC

WATER TEMP.SENSOR (4 pins)

PIN No.	CONNECTION
No. 1	WHITE
No. 2	SHIELD
No. 3	NC
No. 4	BLACK

NAVIGATOR -INTERFACE (5 pins)

PIN No.	CONNECTION
No. 1	SIGNAL INPUT +
No. 2	SIGNAL INPUT -
No. 3	SHIELD
No. 4	SIGNAL OUTPUT +
No. 5	SIGNAL OUTPUT -

3 PIN PLUG for TRANSDUCER

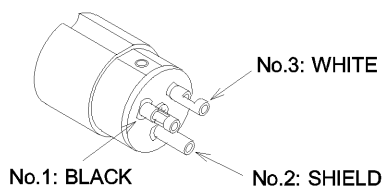

The two leads (No.1 and No.3) may be reversed without affecting the transducer performance.
(No.1: white No.3: black)

In some cases, the colors of the leads differ according to the type of transducer. Solder the cable's leads and shield to the three pins on the plug body.

2 PIN PLUG for POWER SUPPLY CONNECTION

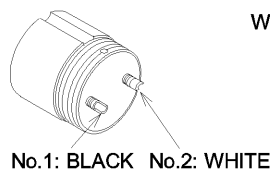

WHITE: POSITIVE TERMINAL

BATTERY

BLACK: NEGATIVE TERMINAL

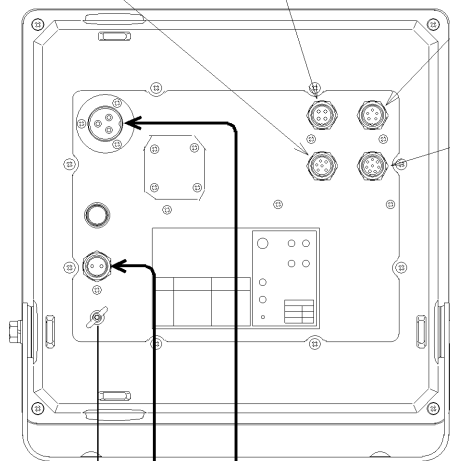

EXTERNAL SOUNDER -INTERFACE (8 pins)

PIN No.	CONNECTION
No. 1	TRIGGER SIGNAL INPUT
No. 2	TRIGGER SIGNAL OUTPUT
No. 3	RX SIGNAL INPUT
No. 4	RX SIGNAL OUTPUT
No. 5	GND
No. 6	N C
No. 7	N C
No. 8	SHIELD

GND

(STANDARD TYPE)

TRANSDUCER



Power requirement: DC10.5 - 40V

Using any power voltage other than the indicated voltage can cause it to lead to fires or electric shocks.

Use the indicated power supplied cables.

Using any power supplied cable other than the indicated cable can cause it to lead to fires.

The ES-1080 must be turned off while connecting/disconnecting the cables.

Otherwise the cables may be damaged and result in fires or electric shocks.

Do not use the cables bent, twisted or stretched by force.

Do not put heavy objects on the cables. Otherwise the cables may be damaged and result in fires or electric shocks.

CONTROL PANEL

CONTROL PANEL

The main functions of the ES-1080 sounder is all controlled by means of the dials and keys.

OPERATION MODE KEYS :

cf PAGE 68
Calls up the user-defined setting or changes the settings.

EXPANSION / VRM KEYS :

cf PAGE 69
Selects the upper expansion start point for Partial expansion mode or enters a vertical marker in the display.

MARK KEY :

cf PAGE 71
Enters a vertical mark line on the display.

RANGE DIAL :

cf PAGE 64
Selects the basic range.

MODE SELECTION DIAL :

cf PAGE 60
Selects the display mode.

FAR GAIN DIAL :

cf PAGE 66/67
Adjusts presentation of received echo in the long range.

POWER SUPPLY KEYS :

cf PAGE 4
Turns on the power or turn the power off.

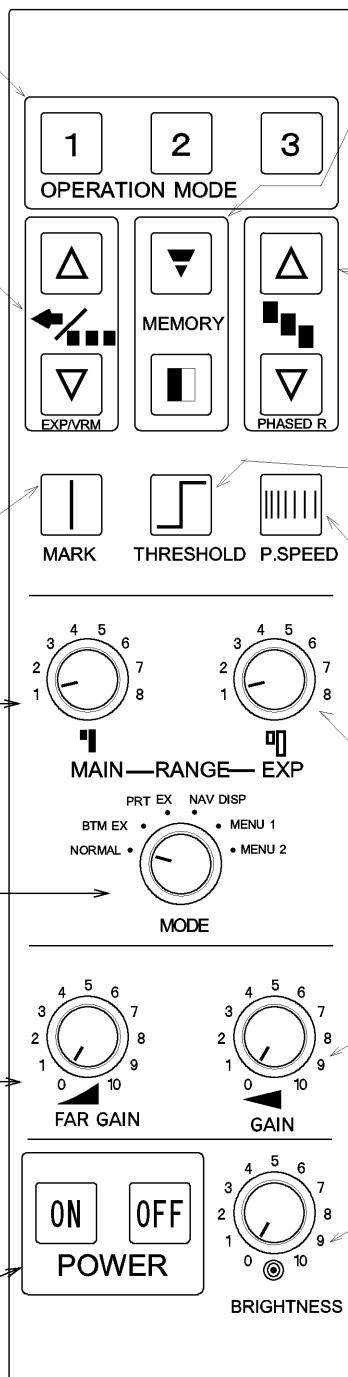

MEMORY WRITE / READ KEY :

cf PAGE 70
MEMORY WRITE KEY inserts data of the right half of the screen. MEMORY READ KEY displays memorized data on the left half of the screen.

PHASED RANGE KEYS :

cf PAGE 70
Adjusts the scale/range of depth between available values.

THRESHOLD KEY :

cf PAGE 73
Eliminates the weak target colors from the display.

PICTURE SPEED KEY :

cf PAGE 72
Selects the rate of picture movement.

EXPANSION RANGE DIAL :

cf PAGE 64
Selects the expansion range for the bottom expansion mode.

GAIN CONTROL DIAL :

cf PAGE 65
Adjusts presentation of received echo.

BRIGHTNESS CONTROL

DIAL : **cf** PAGE 67
Adjusts the display brightness.

MODE EXAMPLE

DISPLAY

The below shows an example for Normal display mode.
 Bottom expansion display mode and Partial expansion display mode are different from this display.

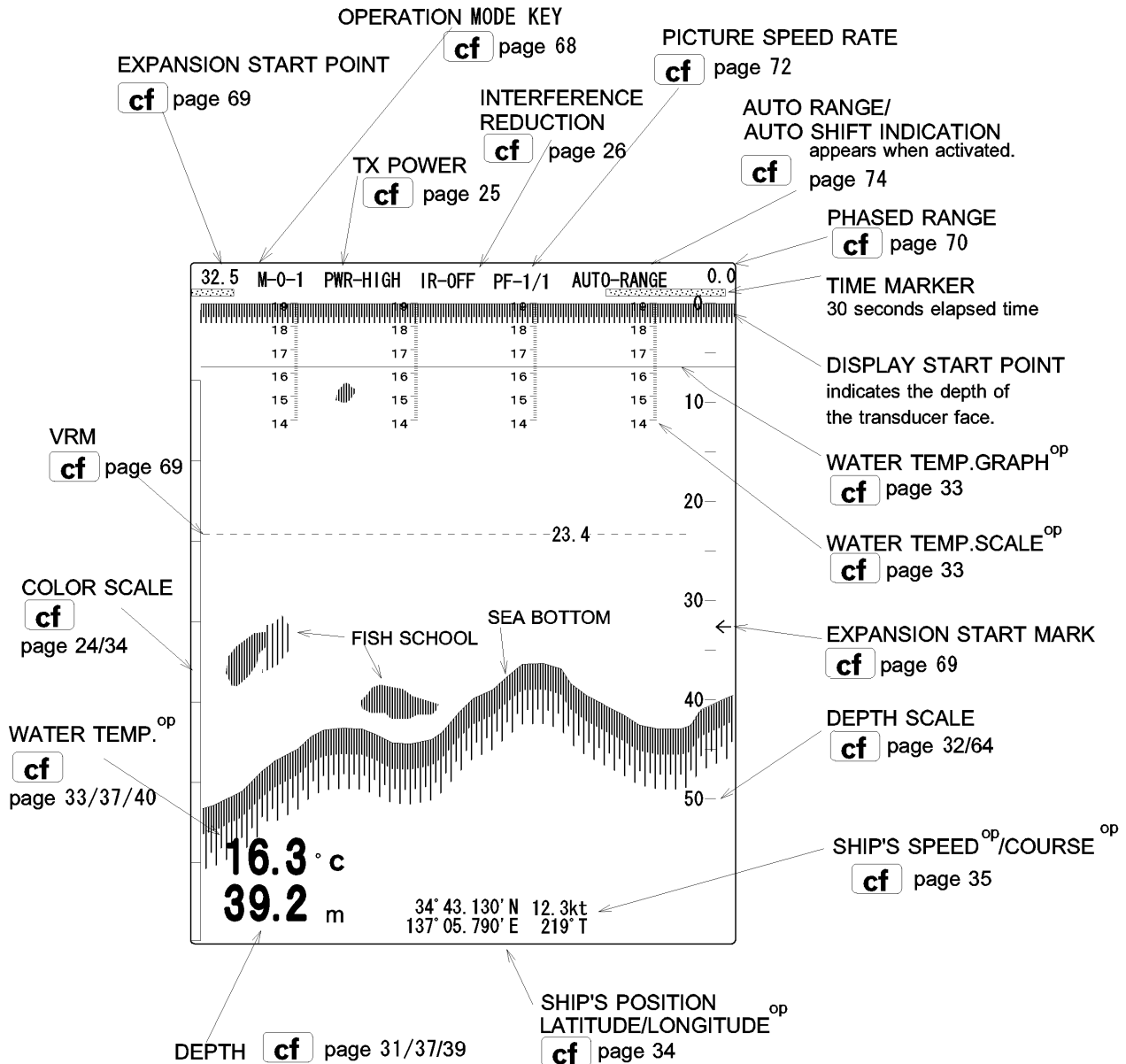

NOTE : ^{op} shows optional equipment required.

INITIAL SETTINGS

This chapter explains the initial function settings and return to factory settings of the ES-1080 Echo sounder.

INITIAL SETTINGS

FACTORY SETTINGS	14
RETURN TO FACTORY SETTINGS	16
(INITIAL SETTINGS)	
USER SETTINGS	16

INITIAL SETTINGS

FACTORY SETTINGS

- Ⓒ This equipment is shipped from the factory with the functions under the following settings. The user is able to re-set these function if/as desired with the user setting mode.

1/2

FUNCTION	FACTORY SETTING (in the box)	USER SETTING MODE
FUNCTION SET GAIN UP TVG D RANGE (DYNAMIC RANGE) CLUTTER TX POWER	OFF · +10 · <input type="text" value="+20"/> · +30 · +40 STC · 1 · 2 · <input type="text" value="3"/> · 4 -3dB · -4dB · -5dB · <input type="text" value="±6dB"/> · +5dB · +4dB · +3dB <input type="text" value="OFF"/> · 1 · 2 · 3 · 4 · 5 · 6 · 7 · 8 · 9 · 10 HIGH · <input type="text" value="LOW"/>	MENU 2 <input type="text" value="cf"/> page 21 -
REDUCTION INTERF RED JAMING RED NOISE RED WHITE LINE	<input type="text" value="OFF"/> · LOW · MIDDLE · HIGH <input type="text" value="OFF"/> · 1 · 2 · 3 · 4 · 5 · 6 · 7 · 8 · 9 <input type="text" value="OFF"/> · ON <input type="text" value="OFF"/> · LOW · MIDDLE · HIGH	<input type="text" value="cf"/> page 26 -
SCREEN DIVISION BTM EXPN SCREEN DIV	<input type="text" value="CONST1"/> · CONST2 · CONST3 · AUTO <input type="text" value="VERT"/> · HORIZ	<input type="text" value="cf"/> page 29 -
DISP ITEM SEL. DEPTH DISP SCALE EXP/VRM TEMP DISP TEMP GRAPH COL. SCALE LAT.LONG. SPEED DISP COURSE MARK DISP.POS DEPTH GRID PICTURE FEED A-SCOPE SCALE FONT	OFF · SMALL · <input type="text" value="MEDIUM"/> · LARGE OFF <input type="text" value="RIGHT"/> · CENTER <input type="text" value="EXP"/> · VRM <input type="text" value="OFF"/> · SMALL · LARGE <input type="text" value="OFF"/> · ON OFF · <input type="text" value="ON"/> <input type="text" value="OFF"/> · ON <input type="text" value="OFF"/> · ON <input type="text" value="OFF"/> · ON <input type="text" value="MARK"/> · TIMER <input type="text" value="LOWER"/> · UPPER <input type="text" value="AUTO"/> · 1 · 2 · 5 · 10 · 20 · 50 · 100 <input type="text" value="AUTO"/> · FIXED <input type="text" value="OFF"/> · ON <input type="text" value="SMALL"/> · LARGE	<input type="text" value="cf"/> page 31 -
UNIT · ADJUST DEPTH UNIT TEMP UNIT SPEED UNIT TEMP ADJ DRAFT DEPTH AVR.	<input type="text" value="m"/> · br · fm · ft <input type="text" value="° C"/> · ° F <input type="text" value="k t"/> · k m / h <input type="text" value="+0.0"/> (- 9.9 ~ + 9.9) <input type="text" value="00.0"/> (00.0 ~ 99.9) <input type="text" value="1"/> · 2 · 3 · 4 · 5 · 6 · 7 · 8 · 9 · 10	<input type="text" value="cf"/> page 39 -

FUNCTION	FACTORY SETTING (in the box)	USER SETTING MODE																								
ALARM SHALLOW DEEP FISH TEMP MAX. TEMP MIN. TEMP RANGE	<table border="0"> <tr> <td><input type="text" value="OFF"/></td> <td>· 0000 (0000 ~ 3999)</td> </tr> <tr> <td><input type="text" value="OFF"/></td> <td>· 0000 (0000 ~ 3999)</td> </tr> <tr> <td><input type="text" value="OFF"/></td> <td>· 6 (1 ~ 7)</td> </tr> <tr> <td><input type="text" value="OFF"/></td> <td>· 35.0 (00.0 ~ 35.0)</td> </tr> <tr> <td><input type="text" value="OFF"/></td> <td>· 00.0 (00.0 ~ 34.9)</td> </tr> <tr> <td><input type="text" value="OFF"/></td> <td>· 00.0 (00.0 ~ 09.8)</td> </tr> </table> <p style="text-align: right;">} in case of °C</p>	<input type="text" value="OFF"/>	· 0000 (0000 ~ 3999)	<input type="text" value="OFF"/>	· 0000 (0000 ~ 3999)	<input type="text" value="OFF"/>	· 6 (1 ~ 7)	<input type="text" value="OFF"/>	· 35.0 (00.0 ~ 35.0)	<input type="text" value="OFF"/>	· 00.0 (00.0 ~ 34.9)	<input type="text" value="OFF"/>	· 00.0 (00.0 ~ 09.8)	<p style="text-align: center;">MENU 2</p> <p>cf page 50 -</p>												
<input type="text" value="OFF"/>	· 0000 (0000 ~ 3999)																									
<input type="text" value="OFF"/>	· 0000 (0000 ~ 3999)																									
<input type="text" value="OFF"/>	· 6 (1 ~ 7)																									
<input type="text" value="OFF"/>	· 35.0 (00.0 ~ 35.0)																									
<input type="text" value="OFF"/>	· 00.0 (00.0 ~ 34.9)																									
<input type="text" value="OFF"/>	· 00.0 (00.0 ~ 09.8)																									
OTHERS COLOR SET OUTER DPTH TRIGGER ECHO SIG OUTPUT T.INTVAL.ADD TRANS RATE PULSE OPE. MODE SHIFT AR TEMP SENSOR A SHIFT LIMIT	<table border="0"> <tr> <td><input type="text" value="A-1"/></td> <td>· A-2 · B-1 · B-2 · C-1 · C-2 · D-1 · D-2 · E-1 · E-2</td> </tr> <tr> <td><input type="text" value="OFF"/></td> <td>· ON</td> </tr> <tr> <td><input type="text" value="INTRNL"/></td> <td>· EXTRNL</td> </tr> <tr> <td><input type="text" value="INTRNL"/></td> <td>· EXTRNL</td> </tr> <tr> <td><input type="text" value="OFF"/></td> <td>· 183N · 183T · 600S</td> </tr> <tr> <td><input type="text" value="000"/></td> <td>(000 ~ 999)</td> </tr> <tr> <td>LOW · <input type="text" value="MEDIUM"/></td> <td>· HIGH</td> </tr> <tr> <td>NARROW · <input type="text" value="NORMAL"/></td> <td>· WIDE · DETAIL · 0.3 (0.3 ~ 3.6)</td> </tr> <tr> <td><input type="text" value="0"/></td> <td>· 1</td> </tr> <tr> <td><input type="text" value="1"/></td> <td>· 5 · 10 · 50 · 100</td> </tr> <tr> <td><input type="text" value="OP-102"/></td> <td>· OP - 41 - 1 · NMEA - 0183</td> </tr> <tr> <td><input type="text" value="999"/></td> <td>(010 ~ 999)</td> </tr> </table>	<input type="text" value="A-1"/>	· A-2 · B-1 · B-2 · C-1 · C-2 · D-1 · D-2 · E-1 · E-2	<input type="text" value="OFF"/>	· ON	<input type="text" value="INTRNL"/>	· EXTRNL	<input type="text" value="INTRNL"/>	· EXTRNL	<input type="text" value="OFF"/>	· 183N · 183T · 600S	<input type="text" value="000"/>	(000 ~ 999)	LOW · <input type="text" value="MEDIUM"/>	· HIGH	NARROW · <input type="text" value="NORMAL"/>	· WIDE · DETAIL · 0.3 (0.3 ~ 3.6)	<input type="text" value="0"/>	· 1	<input type="text" value="1"/>	· 5 · 10 · 50 · 100	<input type="text" value="OP-102"/>	· OP - 41 - 1 · NMEA - 0183	<input type="text" value="999"/>	(010 ~ 999)	<p>cf page 43-</p>
<input type="text" value="A-1"/>	· A-2 · B-1 · B-2 · C-1 · C-2 · D-1 · D-2 · E-1 · E-2																									
<input type="text" value="OFF"/>	· ON																									
<input type="text" value="INTRNL"/>	· EXTRNL																									
<input type="text" value="INTRNL"/>	· EXTRNL																									
<input type="text" value="OFF"/>	· 183N · 183T · 600S																									
<input type="text" value="000"/>	(000 ~ 999)																									
LOW · <input type="text" value="MEDIUM"/>	· HIGH																									
NARROW · <input type="text" value="NORMAL"/>	· WIDE · DETAIL · 0.3 (0.3 ~ 3.6)																									
<input type="text" value="0"/>	· 1																									
<input type="text" value="1"/>	· 5 · 10 · 50 · 100																									
<input type="text" value="OP-102"/>	· OP - 41 - 1 · NMEA - 0183																									
<input type="text" value="999"/>	(010 ~ 999)																									
TX / RX MENU TRANSDUCER FREQUENCY TR FREQUENCY RX FREQUENCY BAND WIDTH	<table border="0"> <tr> <td><input type="text" value="200k"/></td> <td><input type="text" value="50Φ"/></td> <td><input type="text" value="1"/></td> </tr> <tr> <td><input type="text" value="200k"/></td> <td><input type="text" value="Hz"/></td> <td></td> </tr> <tr> <td><input type="text" value="200.000"/></td> <td><input type="text" value="000"/></td> <td></td> </tr> <tr> <td><input type="text" value="200.000"/></td> <td><input type="text" value="000"/></td> <td></td> </tr> <tr> <td><input type="text" value="WIDE"/></td> <td></td> <td></td> </tr> </table>	<input type="text" value="200k"/>	<input type="text" value="50Φ"/>	<input type="text" value="1"/>	<input type="text" value="200k"/>	<input type="text" value="Hz"/>		<input type="text" value="200.000"/>	<input type="text" value="000"/>		<input type="text" value="200.000"/>	<input type="text" value="000"/>		<input type="text" value="WIDE"/>			<p>cf page 55</p>									
<input type="text" value="200k"/>	<input type="text" value="50Φ"/>	<input type="text" value="1"/>																								
<input type="text" value="200k"/>	<input type="text" value="Hz"/>																									
<input type="text" value="200.000"/>	<input type="text" value="000"/>																									
<input type="text" value="200.000"/>	<input type="text" value="000"/>																									
<input type="text" value="WIDE"/>																										
MAIN RANGE (NORMAL RANGE)	The range can be set freely. 1 (<input type="text" value="0 ~ 25"/>)	<p style="text-align: center;">MENU 1 CONTROL PANEL</p>																								
SUB RANGE (EXPANSION RANGE)	1 (<input type="text" value="1"/>)	<p>cf page 19</p>																								
OPERATION MODE MODE SELECTION DIAL PHASED RANGE AUTO RANGE AUTO SHIFT THRESHOLD PICTURE SPEED	NO SETTING 1 (NORMAL DISPLAY) 0 OFF OFF 7 COLORS PF-1 / 1	<p style="text-align: center;">CONTROL PANEL</p>																								
USER SETTING	NO SETTING	<p>cf page 16</p>																								

RETURN TO FACTORY SETTINGS

- ⊙ Ensure the power supply switch is turned off.
Then while holding the Mark key, press the power supply ON key and keep pressing the Mark key until the beep stops and the message "ALL IMPLEMENTED DATA RETURNED TO FACTORY SETTINGS" appears.
Note that it will not be returned to the factory settings when the Mark key is released before the beep stops.
After this operation all functions will then return to the factory setting.

USER SETTINGS

- ⊙ In addition to the factory settings the ES-1080 settings may also be set to functions selected by the user. This function is called USER SETTING. Range scales, gain control levels, color, power levels, etc. may be tailored by the user to fit his preference. The user may easily set the desired function settings by operating as explained below.
 - With this function the user may return to the desired function settings if the unit should become inoperable due to mistaken use of the controls. Please be sure to memorize user settings at the time the unit is first operated. Write down your user settings in case they are accidentally changed, or you wish to use different combinations for different fisheries. i.e. midwater vs. bottom.

1. MEMORIZE USER SETTINGS

- Set all functions and display units to the desired settings. Once all functions have been changed, press the POWER OFF key to turn the power off.
- Next while pressing the Memory read key, hold the POWER ON key to turn on the power and keep pressing the Memory read key until the beep stops and the message "USER INITIAL SETTING WAS MEMORIZED" appears.
Note that it will not be memorized when the Memory read key is released before the beep stops.
- After this operation all functions will be memorized under user setting.

2. RETURN TO USER SETTING

- In case of malfunction, turn the power off once.
Next while pressing the key, press the POWER ON key to turn on the power so that the message "USER INITIAL SETTING WAS CALLED" and then the Sounder Display will appear.
- After this operation all functions will return to the user setting.

3. REVISE USER SETTING

- Reset all functions as required and then memorize the setting using the MEMORIZE USER SETTING procedure as above in 1.

FUNCTION SETTINGS

This chapter provides you the explanation for function settings.
Please set each function before using the ES-1080 to suit individual needs.

MENU 1

RANGE SETTINGS	1. MAIN RANGE	19
	2. EXPANSION RANGE	20

MENU 2

SETTING MENU	21	
FUNCTION SETTINGS	21	
	1. GAIN UP	22
	2. TVG	23
	3. D RANGE	24
	4. CLUTTER	25
	5. TX POWER	25

REDUCTION	1. INTERFERENCE REDUCTION	26
	2. JAMMING REDUCTION	27
	3. NOISE REDUCTION	28
	4. WHITE LINE	28

SCREEN DIVISION	1. BOTTOM EXPANSION	29
	2. SCREEN DIVISION	30

DISPLAY ITEM SELECTION	1. DEPTH DISPLAY SIZE	31
	2. SCALE POSITION	32
	3. EXPANSION/VRM	32
	4. TEMPERATURE DISPLAY SIZE	33
	5. TEMPERATURE GRAPH	33
	6. COLOR SCALE	34
	7. LATITUDE/LONGITUDE	34
	8. SPEED DISPLAY	35
	9. COURSE DISPLAY	35
	10. MARK	36
	11. DISPLAY POSITION	37
	12. DEPTH GRID	37
	13. PICTURE FEED	38
	14. A-SCOPE	38
	15. SCALE FONT	38

<TO BE CONTINUED>

UNIT	1. DEPTH UNIT	39
ADJUSTMENT	2. TEMPERATRE UNIT	40
	3. SPEED UNIT	40
	4. TEMPERATURE ADJUSTMENT	41
	5. DRAFT	41
	6. DEPTH AVERAGE	42
OTHERS	1. COLOR SETUP	43
	2. OUTER DEPTH	45
	3. TRIGGER SIGNAL	45
	4. ECHO SIGNAL	45
	5. OUTPUT	46
	6. TRANSMIT INTERVAL	46
	ADDITION RATE	
	7. TRANSMIT RATE	47
	8. PULSE WIDTH	47
	9. OPERATION MODE	48
	10. SHIFT AVERAGE	48
	11. TEMPERATURE SENSOR	49
	12. AUTO SHIFT LIMIT	49
ALARMS	1. SHALLOW ALARM	50
	2. DEEP ALARM	51
	3. FISH ALARM	52
	4. TEMPERATURE MAX. ALARM	53
	5. TEMPERATURE MIN. ALARM	53
	6. TEMPERATURE RANGE ALARM	54
TR / RX MENU		55
	1. TRANSDUCER	56
	2. FREQUENCY	56
	3. TR FREQUENCY	56
	4. RX FREQUENCY	57
	5. BAND WIDTH	57
	6. JUMPER SETTING	58

RANGE SETTINGS





1. MAIN RANGE

☉ To customize the main ranges.



Example ▪ Factory setting ranges:



m · fm · br :		ft :		VARIABLE RANGES: up to 3000 (m, fm or br) up to 6000 feet
NUMBER	RANGE	NUMBER	RANGE	
1 :	000 - 0025	1 :	0000 - 0050	
2 :	000 - 0050	2 :	0000 - 0100	
3 :	000 - 0100	3 :	0000 - 0150	
4 :	000 - 0150	4 :	0000 - 0200	
5 :	000 - 0200	5 :	0000 - 0300	
6 :	000 - 0300	6 :	0000 - 0500	
7 :	000 - 0500	7 :	0000 - 1000	

☉ Turn the Mode selection dial to “MENU 1” to display the menu below.

- Use the  or  EXP/VRM key to highlight the item to be set.
- Use the  or  Phased range key to set the desired range values.



RANGE SET MENU	
MAIN RANGE	
NUMBER	RANGE
1	000 - 0025
2	000 - 0050
3	000 - 0100
4	000 - 0150
5	000 - 0200
6	000 - 0300
7	000 - 0500

▪ Use the  or  EXP/VRM key to highlight the item you want to change.

▪ Use the  or  Phased range key to set the desired values.

 : makes the range larger.

 : makes the range smaller.

☉ Continuous pressing of the  or  Phased range key will change the range value faster.

☉ Use the  Memory read key to alternate Sub Range with Main Range.

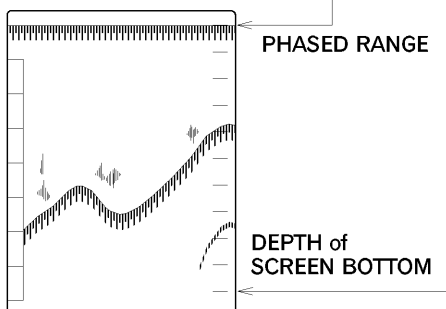

2. EXPANSION RANGE

⊙ To customize the expansion ranges.



Example ▪ Factory setting ranges:



m · f m · b r :		f t :		
NUMBER	RANGE	NUMBER	RANGE	
1:	0 0 0 1	1:	0 0 1 0	VARIABLE RANGES: up to 250 (m, fm or br) up to 500 feet
2:	0 0 0 2	2:	0 0 2 0	
3:	0 0 0 5	3:	0 0 3 0	
4:	0 0 1 0	4:	0 0 4 0	
5:	0 0 2 0	5:	0 0 5 0	
6:	0 0 3 0	6:	0 1 0 0	
7:	0 0 4 0	7:	0 2 5 0	
8:	0 0 5 0	8:	0 5 0 0	

⊙ Turn the mode selection dial to “MENU 1” to display the RANGE SET MENU so that the MAIN RANGE and the EXPANSION RANGE will appear on the screen.

▪ Use the  Memory read key to alternate Expansion Range with Main Range .



RANGE SET MENU	
EXPANSION RANGE	
NUMBER	RANGE
1	0 0 0 1
2	0 0 0 2
3	0 0 0 5
4	0 0 1 0
5	0 0 2 0
6	0 0 3 0
7	0 0 4 0
8	0 0 5 0

▪ Use the  or  EXP/VRM key to highlight the item you want to change.

▪ Use the  or  Phased range key to set the desired values.





 : makes the range larger.

 : makes the range smaller.

⊙ Continuous pressing of the  PHASED R. or  PHASED R. Phased range key will change the range value faster.

SETTING MENU

⊙ Turn the mode selection dial to "MENU 2" to display the MAIN MENU below.



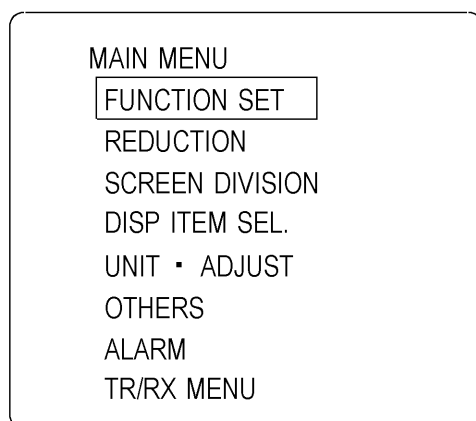

- Use the  or  EXP/VRM key to highlight the item to be set and the  or  Phased range key to select the desired function setting.

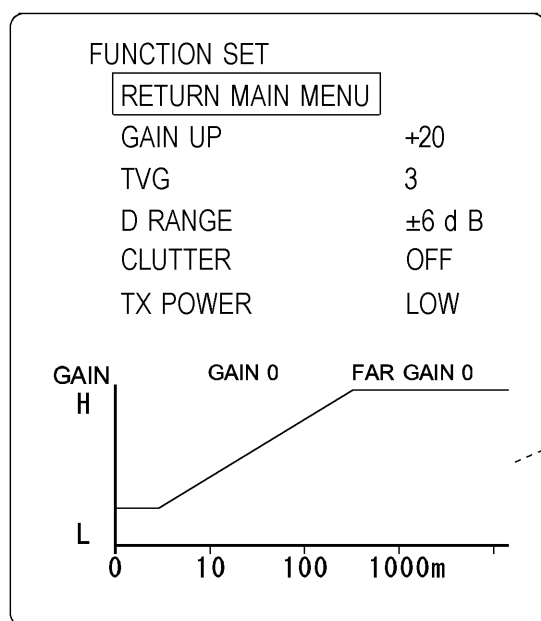

- After setting each function, memorize them by using "USER SETTING".
 page 16
- TR/RX MENU appears only when the ES-1080 applies to FF system.

FUNCTION SETTINGS



- Use the  or  EXP/VRM key to highlight the item to be set.
- Use the  or  Phased range key to return to MAIN MENU.



GAIN DIAGRAM

The following parameters that adjust the displayed picture are shown in the diagram left.

- TVG curve, Gain up, Gain dial and Far gain dial -

1. GAIN UP

☉ This function makes it possible to display a clearer picture of the full range and control sensitivity at various depths. **cf** page 65

- Use the  or  Phased range key to select the gain adjust level.
PHASED R.
 (OFF → + 10 → + 20 → + 30 → + 40 → OFF).

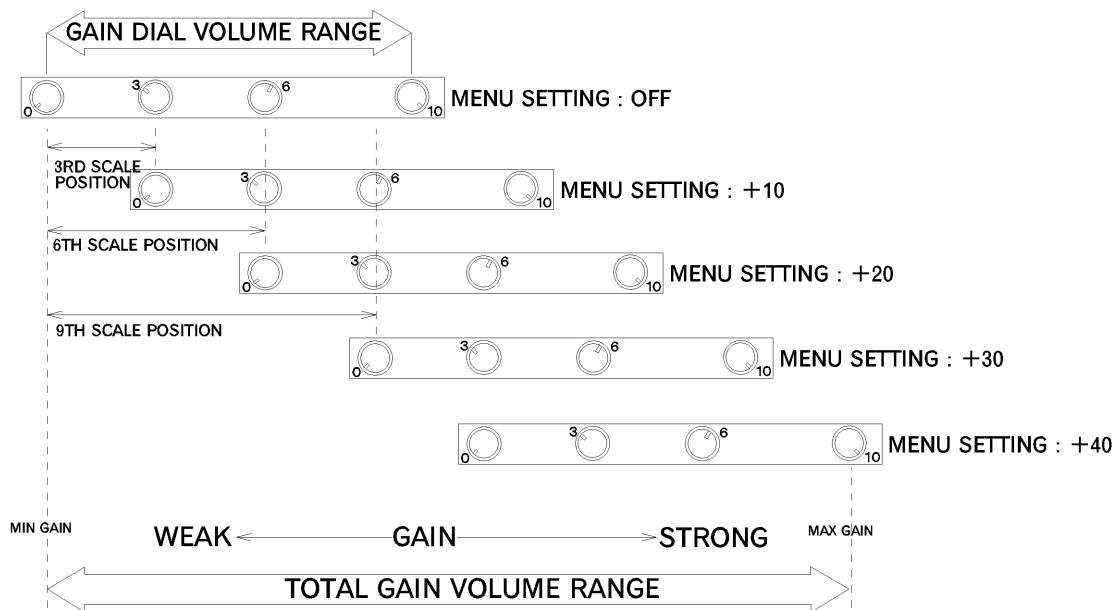

- When the menu gain adjust setting is changed from OFF to +10dB, the gain dial volume increases 3 points on the scale.
- When the menu gain adjust setting is OFF and the front panel dial is on 3, it has the same result as when the menu gain adjust setting is +10dB and the gain dial is on 0.

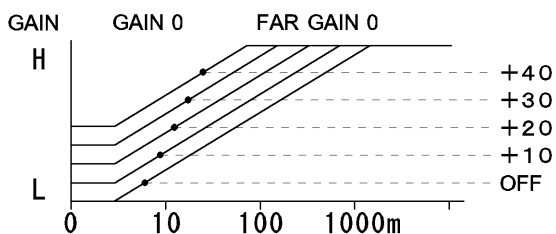



- When the menu gain adjust setting is changed, the diagram changes as shown left. The left shows an example under the below conditions of the standard specifications.
 TVG curve : 3
 Gain dial : 0
 Far gain dial : 0

Turning the Gain dial clockwise increases the above shown value between 0 and 30.
 Turning the Far gain dial clockwise increases the above shown value between 0 and 50.

2. TVG

- ⊙ The TVG function may be adjusted according to the strength of the target echo.
- As the echoes returning from the bottom and from fish targets get weaker as the depth increases it is advantageous to have a Time Variable Gain that automatically compensates for the loss in signal strength.

- Use the  or  PHASED R. keys to select the TVG adjust level,

(1 → 2 → 3 → 4 → STC → 1).

- STC : STC function
- 1 : TVG CURVE ①
- 2 : TVG CURVE ②
- 3 : TVG CURVE ③
- 4 : TVG CURVE ④

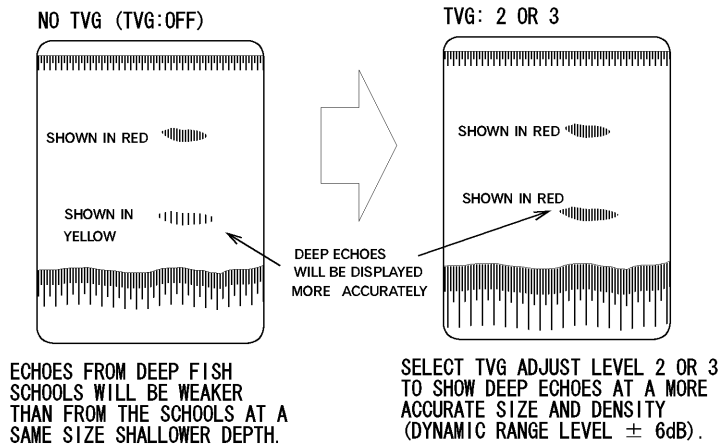
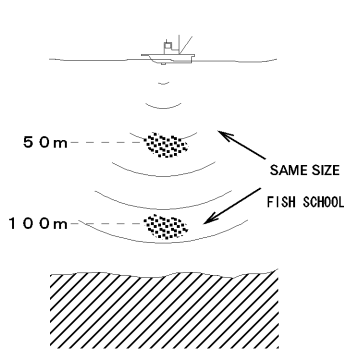
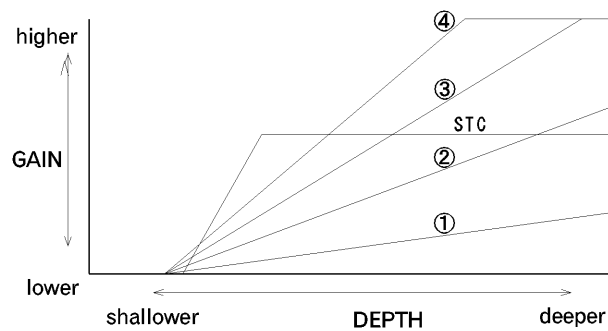



NOTE !

- ~~~~~
- ⊙ Note the TVG function setting influences the far gain adjust and the gain adjust functions.
- ~~~~~

3. D RANGE (DYNAMIC RANGE)

- ◎ By shifting the dynamic range, the operator is able to discriminate more precisely the size, depth and density of the fish school.

Experimenting with this function will give you the best setting for various fishing operations.

- Each press of the  or  PHASED R. key changes the dynamic range level ($\pm 6\text{dB}$, $\rightarrow + 5\text{dB}$, $\rightarrow + 4\text{dB}$, $\rightarrow + 3\text{dB}$, $\rightarrow - 3\text{dB}$, $\rightarrow - 4\text{dB}$, $\rightarrow - 5\text{dB}$, $\rightarrow \pm 6\text{dB}$).

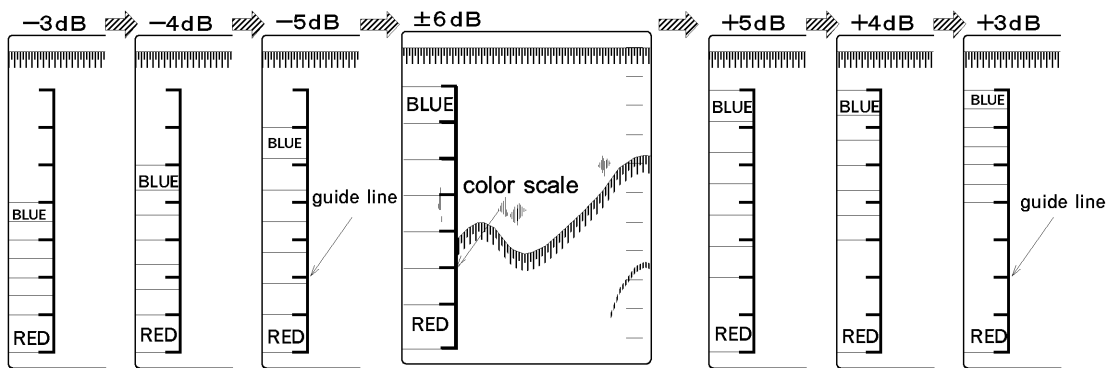

This diagram shows the comparative signal threshold levels to the standard $\pm 6\text{dB}$ for the dynamic ranges.

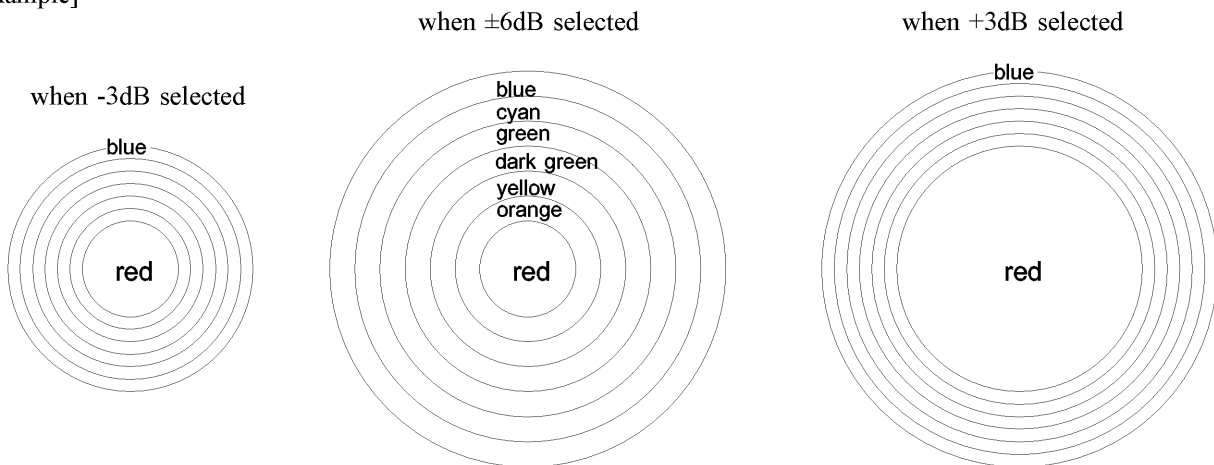

When the dynamic range is changed from $\pm 3\text{dB}$ to $\pm 5\text{dB}$, this range will be displayed in 7 colors.

[example]



4. CLUTTER

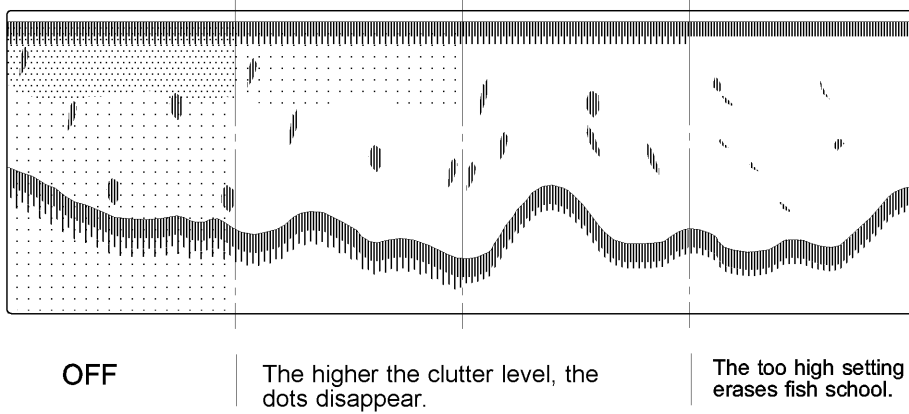

⊙ By using this function the unwanted weak echo can be get rid of.

- Each press of the  or  Phased range key changes the level to suppress clutter (OFF → 1 → 2 → 3 → 4 → 5 → 6 → 7 → 8 → 9 → 10 → OFF).



5. TX POWER

⊙ The output power of the ultrasonic soundwave may be selected.



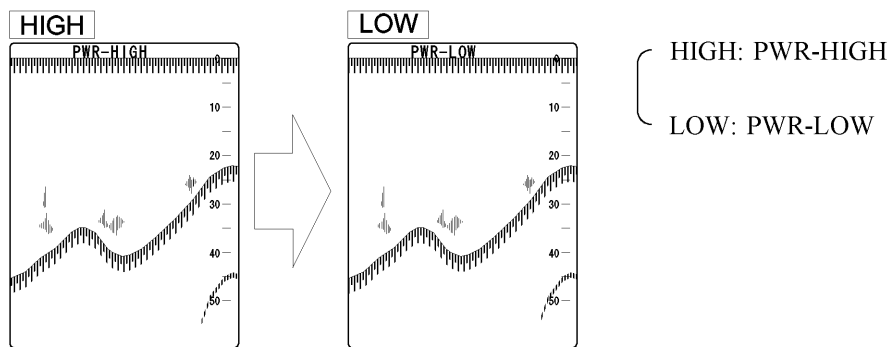

- Each press of  or  Phased range key changes the output power " HIGH...LOW...HIGH...".
- The present level of TX POWER appears on the top of the screen as shown below.



note: Without the setting of TX/RX menu this TX POWER can not be changed, in case of the use of the ES-1080FFS.



REDUCTION

REDUCTION	
RETURN MAIN MENU	
INTERF RED	OFF
JAMING RED	OFF
NOISE RED	OFF
WHITE LINE	OFF

- Use the  or  EXP/VRM key to highlight the item you want to change.
- Use the  or  PHASED R. key to set the desired values.

1. INTERFERENCE REDUCTION

☉ To reduce interference from nearby fishing vessels.

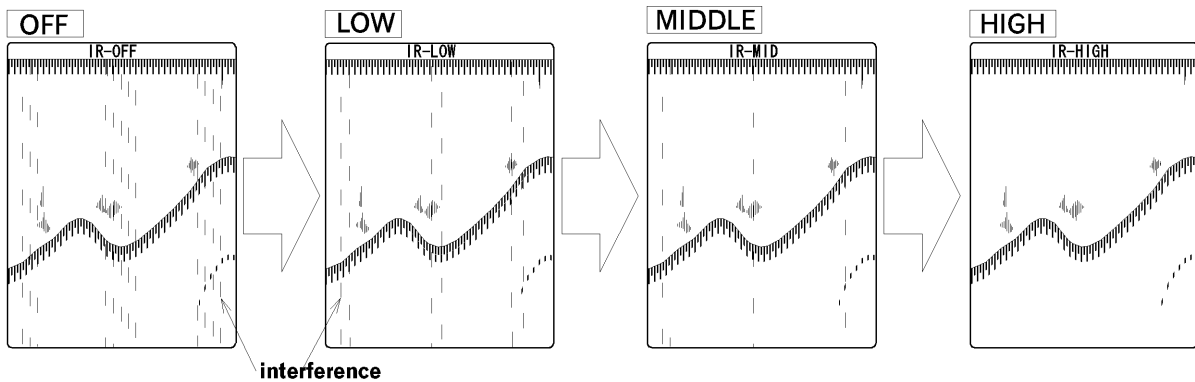

- Each press of the  or  PHASED R. key changes the level of reduction, (OFF → LOW → MIDDLE → HIGH → OFF).
- OFF indicates this function is inactive.
- As the level of the setting closes to HIGH, higher level of reduction is set and the level of reducing interference appears at the top of the screen.



- ☉ Some types of noise interference may not be reduced.
- ☉ Do not select excessive level than the level to be needed since the weak echoes are erased.

2. JAMMING REDUCTION

◎ The combined use of Interference reduction and Jamming reduction is effective in reducing noise due to jamming from other ships.

- Each press of the  or  PHASED R. key changes the level, (OFF → 1 → 2 → 3 → 9 → OFF) .

- Off indicates this function is inactive and the higher level it is set, the more irregular data appears like below. The level 9 is the max.

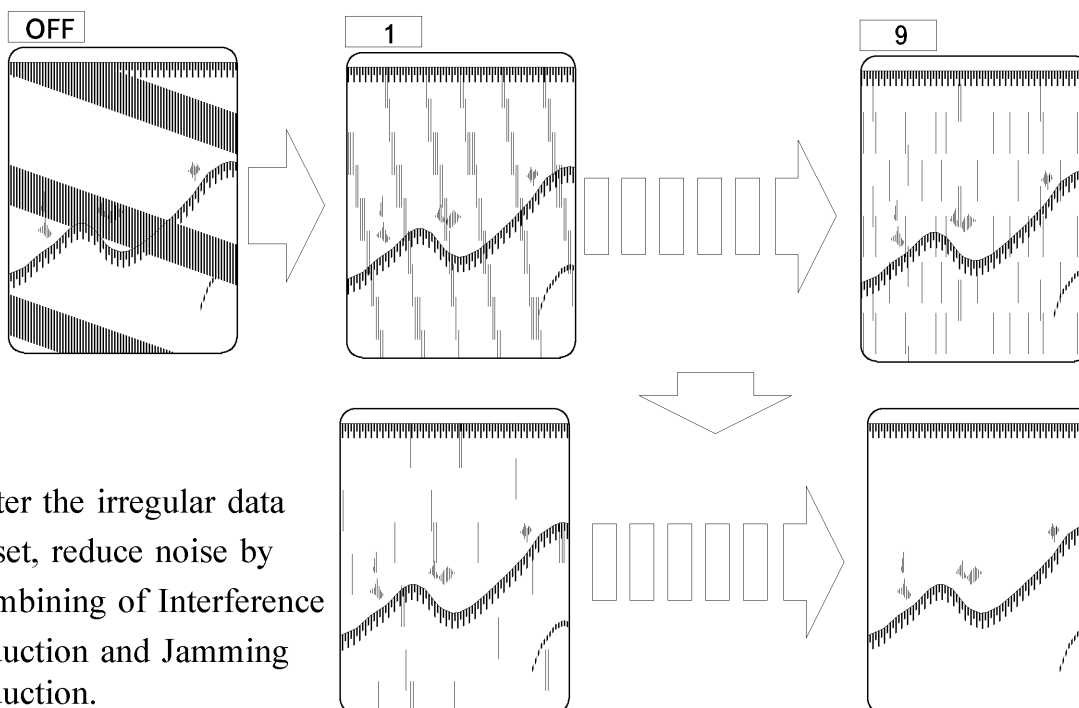

- After the irregular data is set, reduce noise by combining of Interference reduction and Jamming reduction.





- ◎ Do not use INTERFERENCE RED combined with excessive level of JAMMING RED, since the weak echoes are erased.
- ◎ Do not select an excessive level of INTERFERENCE RED., since the weak echoes are erased.

WHAT IS "JAMMING"?

- ~~~~~
- ◎ By receiving sound waves from a neighboring ship's equipment of which frequencies are the same or similar, they influence each other and appear on the screen. Their change occasionally are seen doubled, up and down or the counter direction as Jamming.
- ~~~~~

3. NOISE REDUCTION

☉ To reduce the noise cluttering the entire screen.

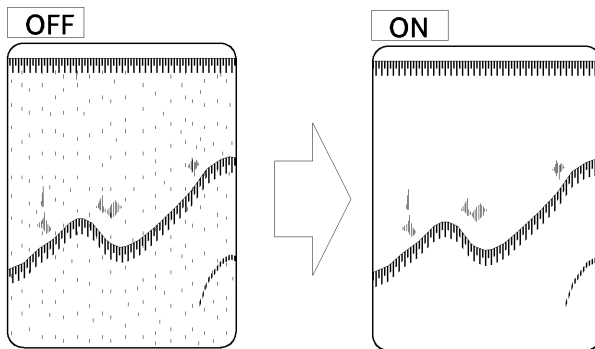

- Each press of the  or  Phased range key changes ON/OFF alternately.
- OFF: The noise suppressing action is disabled.



☉ Some noise reflections may not be reduced.

4. WHITE LINE



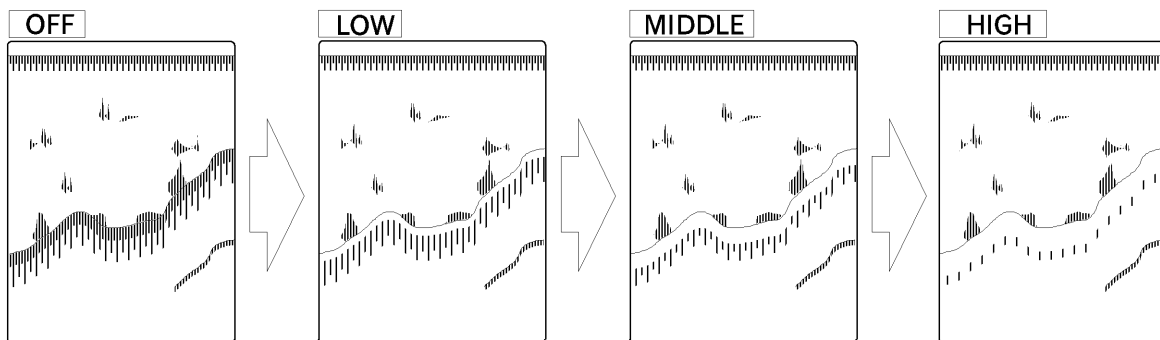

☉ The function of the White Line is to help in discriminating the bottom and fish lying on or very close to the bottom.

- Each press of the  or  Phased range key changes the White Line control level, (OFF → LOW → MIDDLE → HIGH → OFF).
- OFF: The White Line control is disabled.

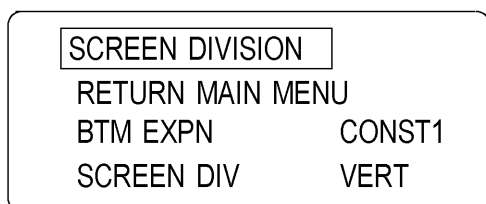



SCREEN DIVISION



- Use the  or  EXP/VRM key to highlight the item you want to change.
- Use the  or  Phased range key to set the desired values or to return to MAIN MENU display when RETURN MAIN MENU highlighted.

1. BOTTOM EXPANSION

- ⊙ When you activate the Bottom Expansion Mode, as in the drawing in the next page, the areas of the bottom contour can be selected by the following shifts and displayed across the screen for close observation of the echoes of interest on or near of the bottom.

- Each press of the  or  Phased range key changes the setting.

(CONST 1 → CONST 2 → CONST 3 → AUTO → CONST 1)

- CONST 1 : The upper part of the bottom is displayed with the expansion range.
- CONST 2 : Display position is shifted deeper than CONST 1.
- CONST 3 : Display position is shifted deeper than CONST 2.
- AUTO : To detect the bottom automatically with the bottom expansion range.

<TO BE CONTINUED>

SCREEN DIVISION : HORIZONTAL

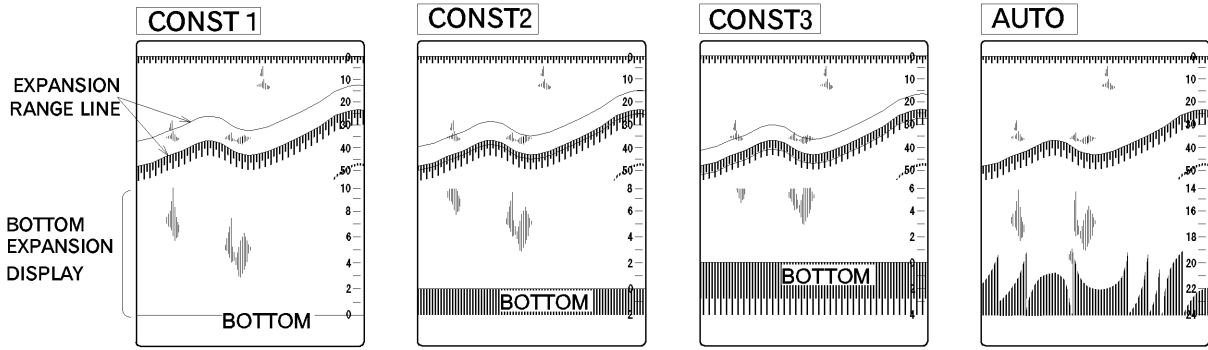

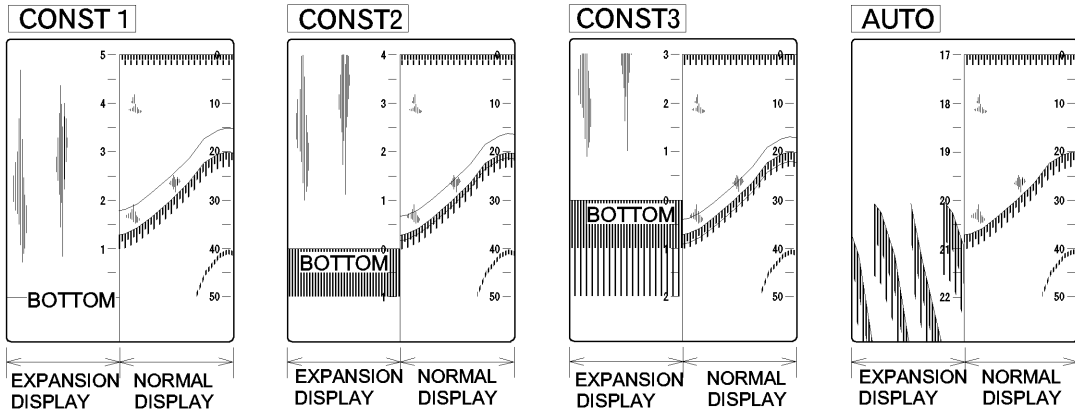

SCREEN DIVISION : VERTICAL



2. SCREEN DIVISION

⊙ To select the screen division either VERTICAL or HORIZONTAL.



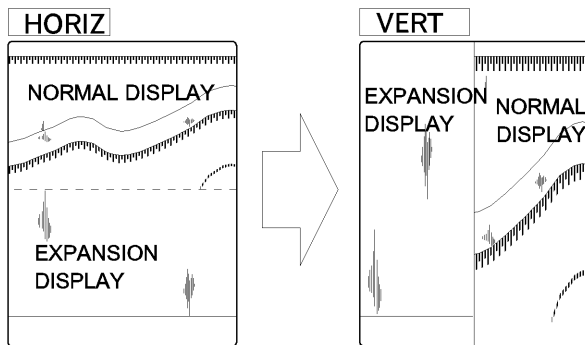

- Each press of the  or  PHASED R. key changes HORIZ with VERT alternately.

- ┌ HORIZONTAL : displays the picture which is divided into horizontally. (upper/lower)
- └ VERTICAL : displays the picture which is divided into vertically. (left/right)





DISPLAY ITEM SELECTION

DISP ITEM SEL.	
RETURN MAIN MENU	
DEPTH DISP	MEDIUM
SCALE	RIGHT
EXP/VRM	EXP
TEMP DISP	OFF
TEMP GRAPH	OFF
COL. SCALE	ON
LAT.LONG.	OFF
SPEED DISP	OFF
COURSE	OFF
MARK	MARK
DISP.POS	LOWER
DEPTH GRID	AUTO
PICTURE FEED	AUTO
A-SCOPE	OFF
SCALE FONT	SMALL

- Use the  or  EXP/VRM key to highlight the item you want to change.
- Use the  or  Phased range key to set the desired values or to return to MAIN MENU display when RETURN MAIN MENU highlighted.

1. DEPTH DISPLAY SIZE

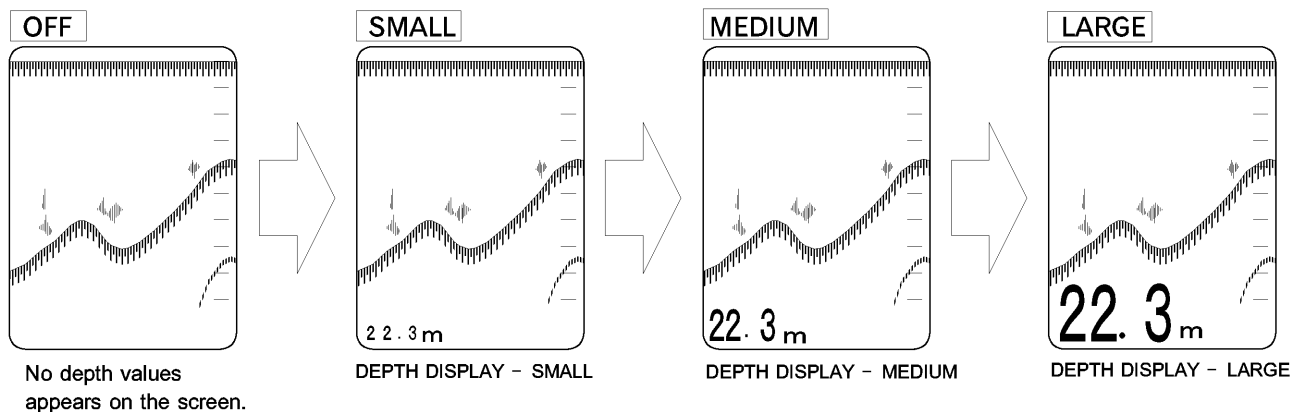

☉ To select the size of the digital display for depth.

- Each press of the  or  Phased range key changes the size of digital display for depth, (OFF → SMALL → MEDIUM → LARGE → OFF).



2. SCALE POSITION

☉ To select the depth scale position.

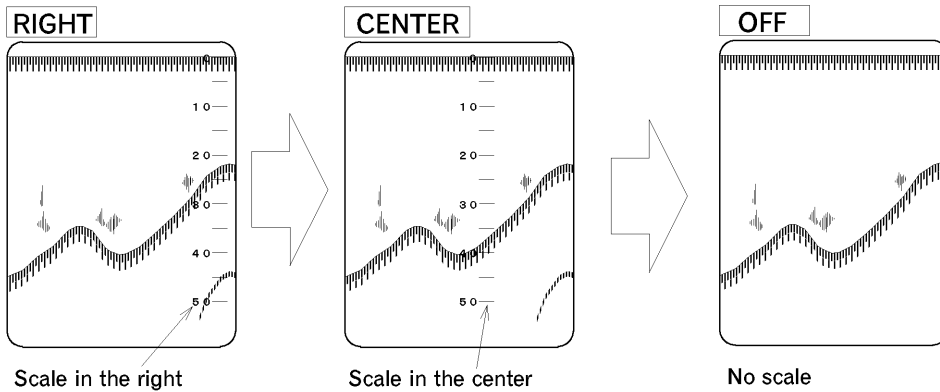

- Each press of the  or  PHASED R. key changes the Scale position display, (OFF → RIGHT → CENTER → OFF) .

You can select the center or right of scale position display.



3. EXP/VRM

☉ To activate the Expansion start point or the horizontal dotted line for digital depth on the screen.

- Each press of the  or  PHASED R. key changes EXP with VRM alternately.

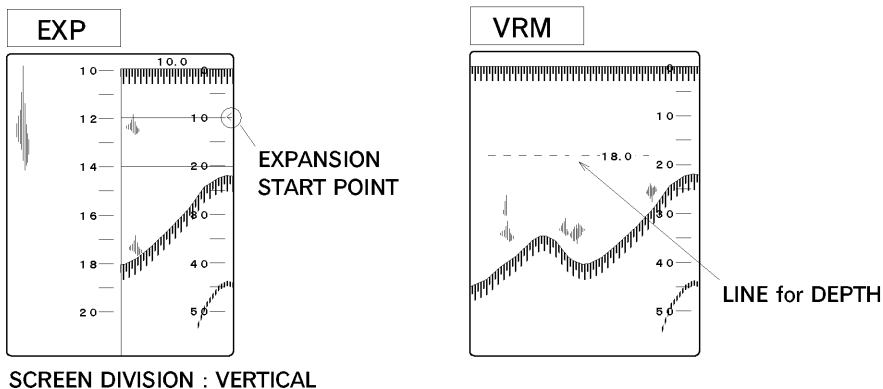

EXP : activates the Expansion start point.
 VRM : activates the Dotted line for digital depth.

cf page 69



4. TEMPERATURE DISPLAY SIZE

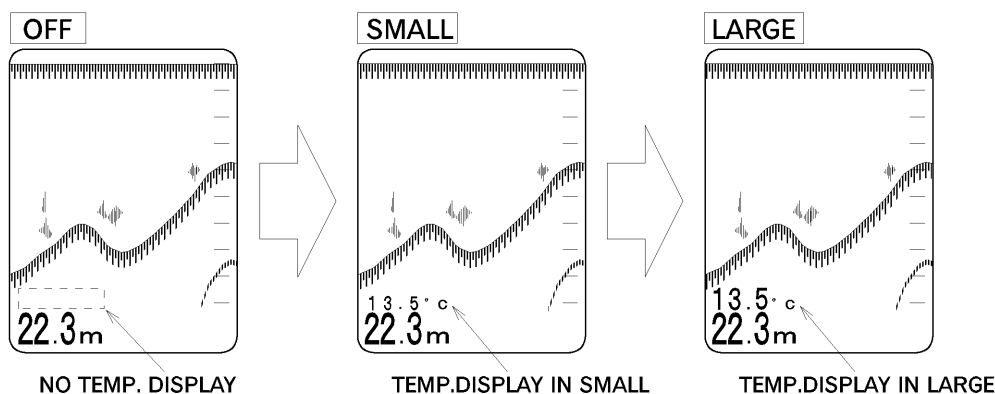

◎ To select the size of digital display for water temperature when an optional water temperature sensor is connected.

- Each press of the  or  Phased range key changes the size, (OFF → SMALL → LARGE → OFF).



5. TEMPERATURE GRAPH

◎ To select the display of the Temperature Graph either ON or OFF when an optional water temperature sensor is connected.

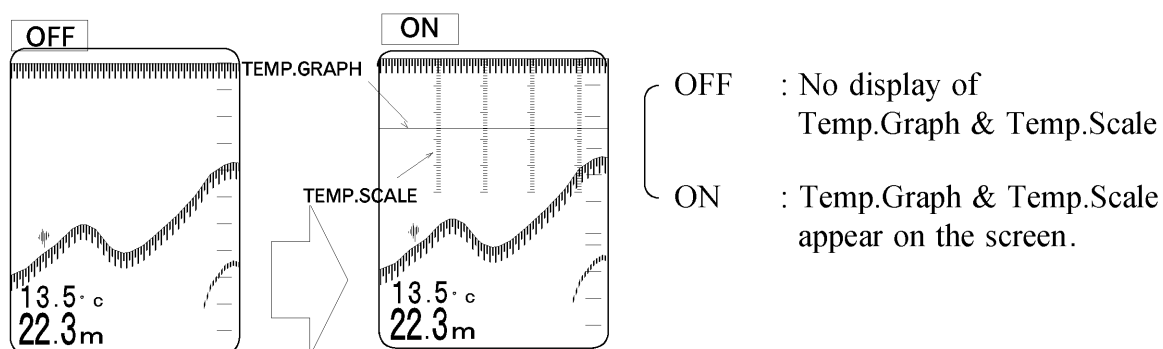

- Each press of the  or  Phased range key changes On with OFF alternately.



- ◎ To present a temperature, temp.graph and temp.scale will require that the ES-1080 is connected to an optional temp. sensor. Select the sizes of these displays via "MAIN MENU - DISP. ITEM SEL.- TEMP.DISP".
- They will not appear on the screen when "TEMP.DIP - OFF" selected.
- Please select OFF while disconnecting the temp.sensor.

6. COLOR SCALE

☉ To select Color Scale display either ON or OFF.

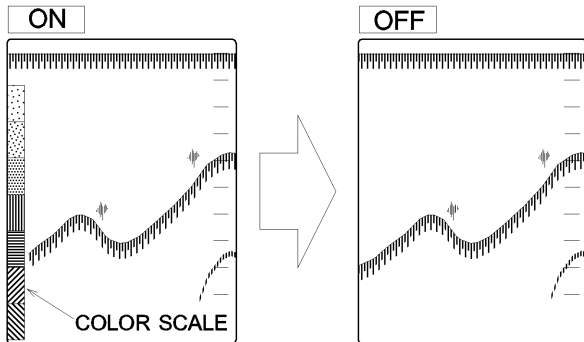

- Each press of the  or  PHASED R. key changes ON with OFF alternately.



- ON : Color scale appears on the screen.
- OFF : Color scale disappears from the screen.

7. LATITUDE/LONGITUDE

☉ To present ship's position in the ES-1080 display will require that a navigator is connected via the NMEA (NMEA-0183) input port.

- Each press of the  or  PHASED R. key changes On with OFF alternately.

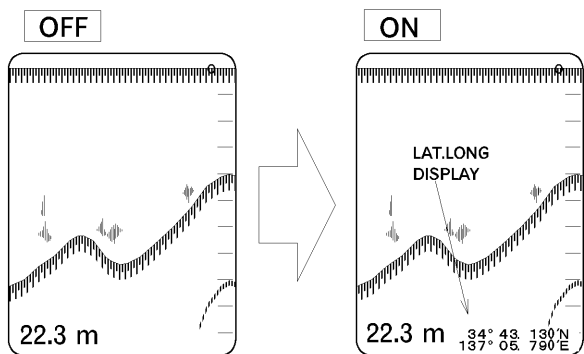

- ON : Position in latitude/longitude appears on the screen.
- OFF : Position (latitude/longitude) presentation disappears from the screen.



NOTE !

The display for Lat/Long, Ship speed and Course in the following page appears on the screen only when NMEA-0183 input signal is interfaced.

cf page 10

8. SPEED DISPLAY

☉ To present ship's speed in the ES-1080 display will require that a navigator is connected.

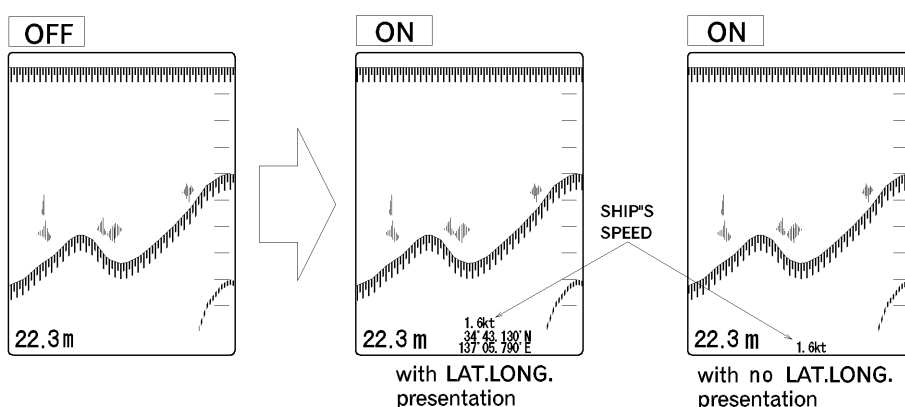

- Each press of the  or  Phased range key changes On with OFF alternately.

- ON : Speed presentation appears on the screen.
- OFF : Speed presentation disappears from the screen.



9. COURSE DISPLAY



☉ To present ship's course in the ES-1080 display will require that a navigator is connected.

- Each press of the  or  Phased range key changes ON with OFF alternately.

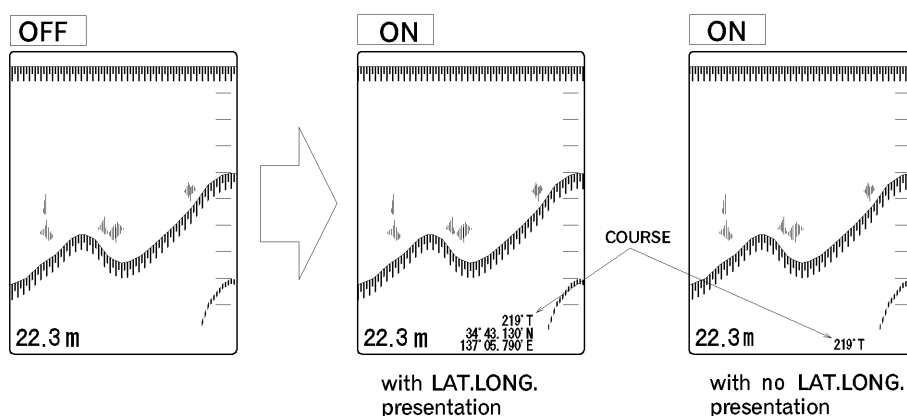
- ON : Course presentation appears on the screen.
- OFF : Course presentation disappears from the screen.



10. MARK

- ⊙ To select the function with  MARK key either MARK or TIMER.
- Each press of the  or  Phased range key changes MARK with TIMER alternately.

MARK : To place a vertical line on the right edge of the screen.
 TIMER : To time between the two lines.

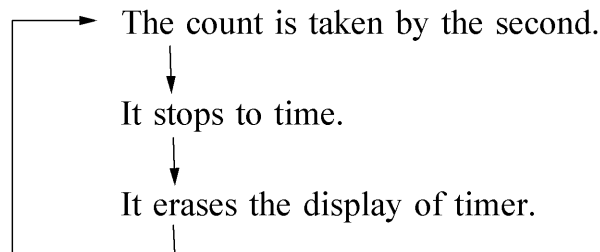

- ⊙ Every time MARK key is pressed, the following procedure is performed.
 It displays a line and starts to time between two lines.



- ⊙ The maximum timing display is 60 minutes.
 It starts to display from 1 second, after it times 60 minutes.
- ⊙ Timer stops and is erased when other function settings are changed.

11. DISPLAY POSITION (for DEPTH and TEMPERATURE)

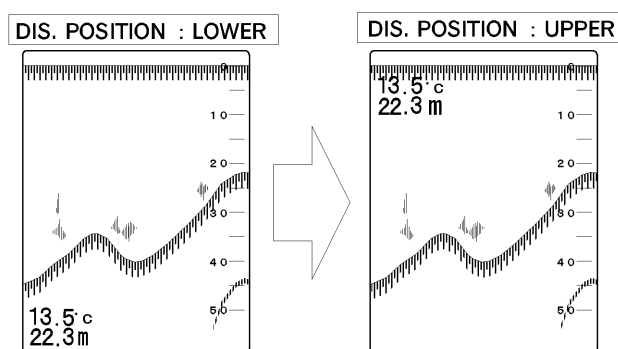

⊙ To select the position for Depth and Temperature presentation on the screen.

- Each press of the  or  PHASED R. key changes LOWER with UPPER alternately.



12. DEPTH GRID

⊙ To select Depth scale unit.

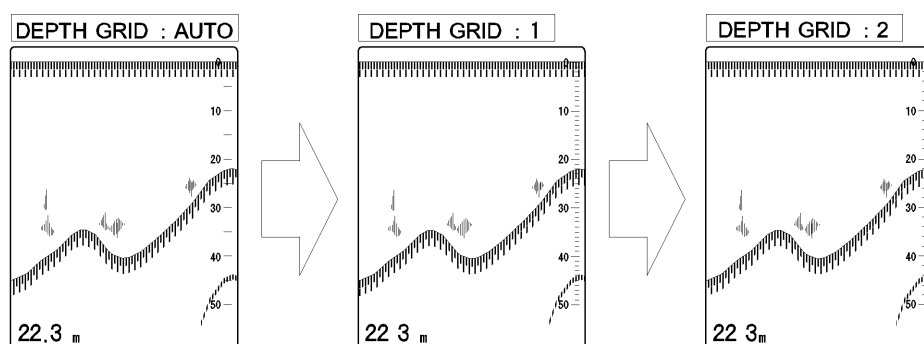

- Each press of the  or  PHASED R. key change the values.

(AUTO → 1 → 2 → 5 → 10 → 20 → 50 → 100 → AUTO)





13. PICTURE FEED

⊙ You can select Picture feed control either AUTO or FIXED.

- Each press of the  or  Phased range key changes the setting, Picture feed control AUTO with FIXED.
- "AUTO" : Picture moves to the left by the speed rate in accordance with the current range in use.
- "FIXED" : Picture moves to the left by the speed rate independently of the range in use. The rate value is entered by Picture Speed key marked .

14. A-SCOPE

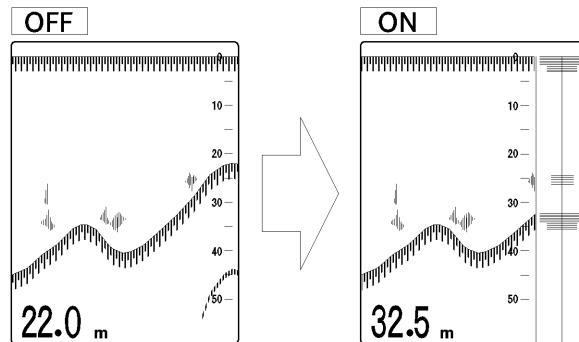

⊙ The amplitude scope which appears in the right side of the echo display, can be turned on and off.

- Each press of the  or  Phased range key alternates ON with OFF.
- ON : A-Scope display appears on the right one-fourth of the screen.
- OFF : A-Scope display disappears from the screen.



15. SCALE FONT



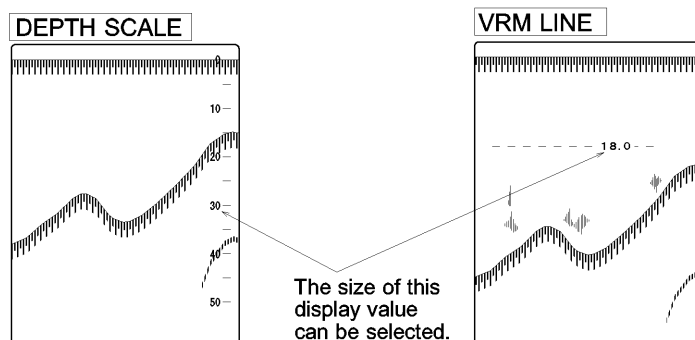

⊙ The font size for the depth scale can be selected.

Each press of the  or  Phased range key changes the size SMALL with LARGE alternately.





UNIT · ADJUSTMENT

UNIT · ADJUST	
RETURN MAIN MENU	
DEPTH UNIT	m
TEMP UNIT	° C
SPEED UNIT	k t
TEMP ADJ	+ 0 . 0
DRAFT	0 0 . 0
DEPTH AVR.	1

- Use the  or  EXP/VRM key to highlight the item you want to change.
- Use the  or  PHASED R. key to set the desired values or to return to MAIN MENU display when RETURN MAIN MENU highlighted.

1. DEPTH UNIT

The unit of depth may be selected.

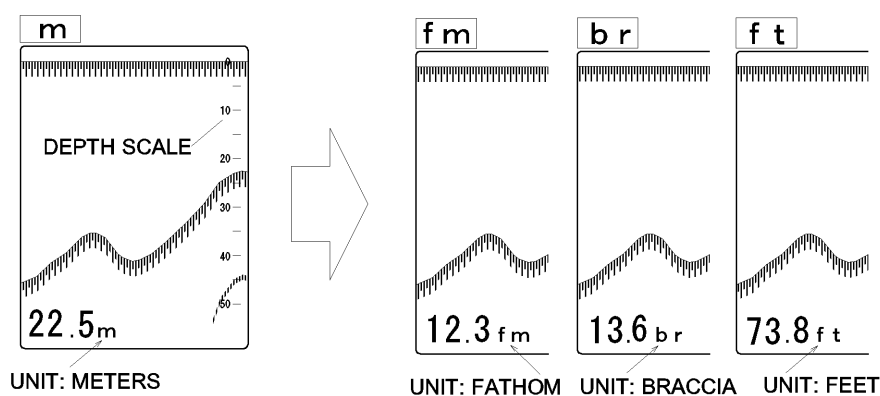

Each press of the  or  PHASED R. key changes the unit.
(m → fm → br → ft → m)

- m : to display the unit meters.
- fm : to display the unit fathom. (1fm: 1.8288m)
- br : to display the unit braccia. (1br: 1.65m)
- ft : to display the unit feet. (1ft: 0.3048m)



2. TEMPERATURE UNIT

The unit of water temperature display may be selected when an optional water temp. sensor connected.

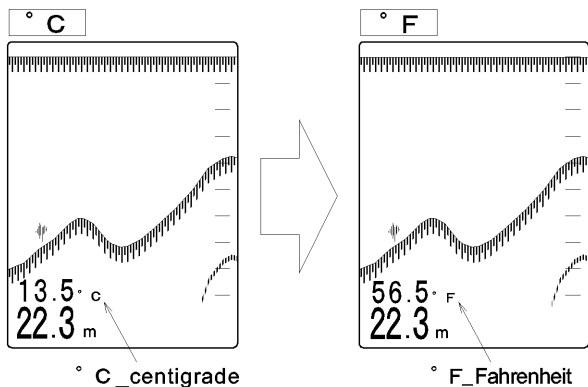

Each press of the  or  Phased range key changes the unit either "° C" or "° F".



° C : Centigrade
° F : Fahrenheit

3. SPEED UNIT

The unit of ship's speed display may be selected when an external navigator connected.

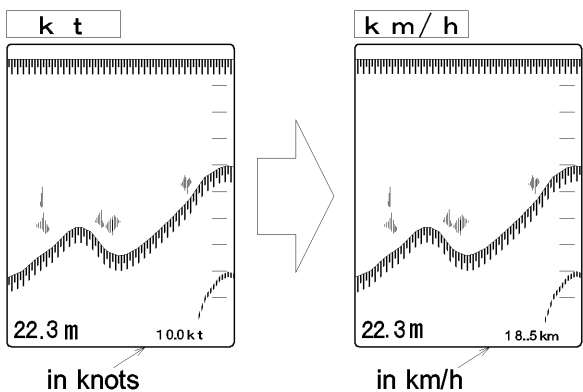

Each press of the  or  Phased range key changes the unit either "kt" or "km/h".





kt : Speed can be shown in knots.
1kt = 1.852 km/h
km/h : Speed can be shown in kilometers/hour.

4. TEMPERATURE ADJUSTMENT

To adjust the water temperature displayed in the screen with an optional water temp. sensor connected.

Every time the  or  Phased range key is pressed, it is adjusted by 0.1° in the range from - 9.9 to + 9.9.



+ 9 . 9 : The maximum temperature adjustment
 + 0 . 0 : No adjustment
 - 9 . 9 : The minimum temperature adjustment



 : increases the values.
 PHASED R.
 : decreases the values.

5. DRAFT

◎ The ES-1080 provides the draft height adjust control for displaying the depth readout from sea level. Usually, the ES-1080 shows up the depth readout from transducer surface to the bottom.

When your ship's draft height is 1 meter and actual depth from sea level is 5 meters, the display of depth readout is normally 4 meters. If necessary, you can change the difference by the following adjust.

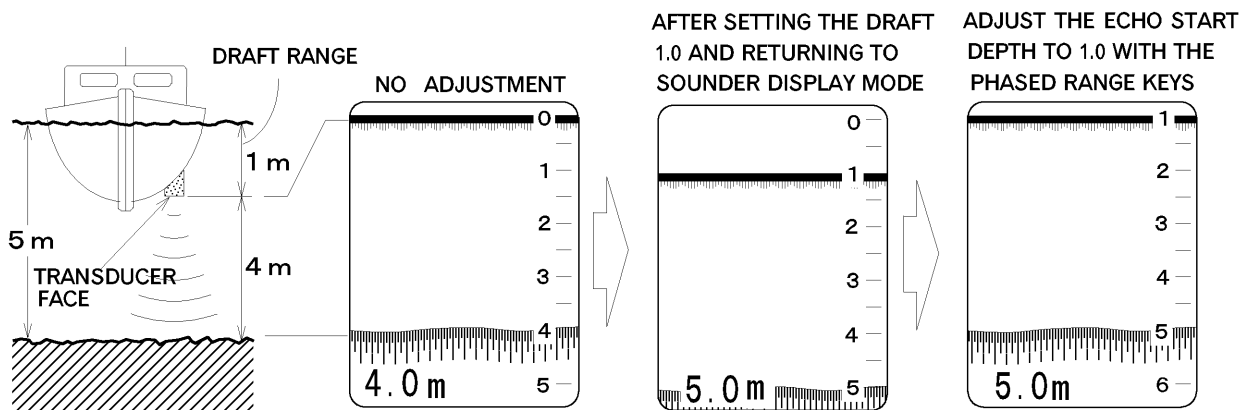

• Press  or  Phased range key to enter the draft range value. **cf** page 70

0 0 . 0 : disabled.
 9 9 . 9 : max. range.
 : increases the range.
 PHASED R.
 : decreases the range.



6. DEPTH AVERAGE

⊙ By activating this function the changing depth is averaged when the ship is violently rolling or pitching, etc.

Each press of  or  Phased range key changes the setting,

PHASED R.

"1 ... 2 ... 3 10 ... 1 ...".





The number of equalization expresses the number of times of discharge of a sound wave. " 1" has no equalization and "2.....10" equalizes the depth-sounding value for discharge of a sound wave each time.



⊙ Note that the depth values are differ from actual depth when the function of equalization is used in a place with much ups and downs of the seabed.

OTHERS



OTHERS	
RETURN MAIN MENU	
COLOR SET	A - 1
OUTER DPTH	OFF
TRIGGER	INTRNL
ECHO SIG	INTRNL
OUTPUT	OFF
T.INTVAL ADD	000
TRANS RATE	MEDIUM
PULSE	NORMAL
OPE. MODE	0
SHIFT AR	1
TEMP SENSOR	OP-102
ASHIFT LIMIT	999

- Use the  or  EXP/VRM key to highlight the item you want to change.
- Use the  or  PHASED R. key to set the desired values or to return to MAIN MENU display when RETURN MAIN MENU highlighted.

1.COLOR SETUP (COLOR PALETTE FUNCTIONS)

- © There is a total of 10 palettes, A-1, A-2, B-1, B-2, C-1, C-2, D-1, D-2, E1 and E2. A-1, A-2, B-1, B-2, C-1, C-2, D-1 and D-2 are fix and therefore not adjustable.



Palette E-1 and E-2 can be customized to suit individual needs and wishes.
The initial settings: E-1=A-1 and E-2=B-1

Each press of the  or  PHASED R. key changes the palette setup,



"A-1...A-2...B-1...B-2...C-1...C-2...D-1...D-2...E-1...E-2 and A-1".

}	A-1 · A-2 · B-1 · B-2	: fix and not adjustable
	C-1 · C-2 · D-1 · D-2	
E-1 · E-2 : make your own special palette setup		

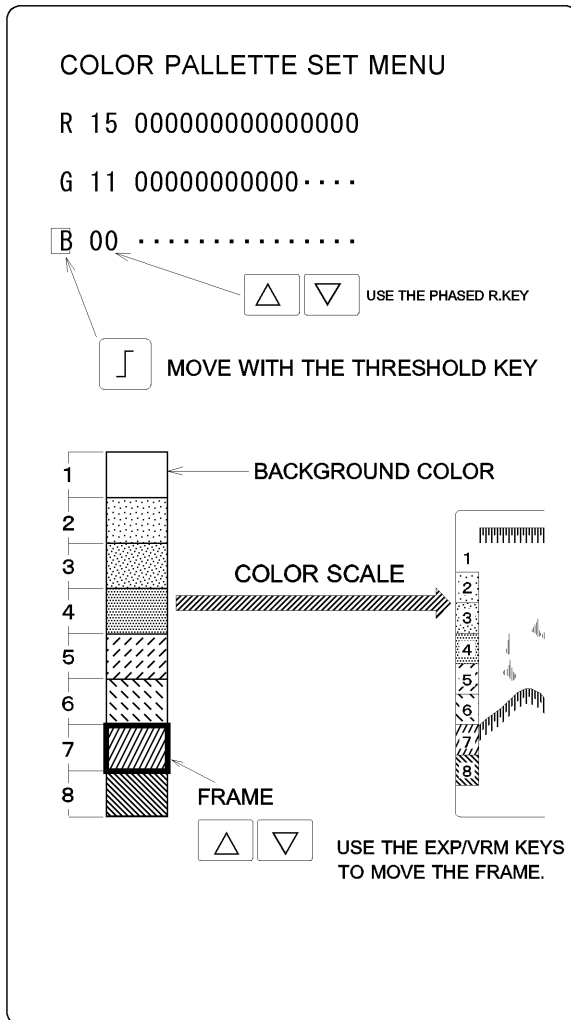

< TO BE CONTINUED >

- ◎ Select E-1 or E-2 with the  or  PHASED R. key and then press the  Threshold key to display the menu below if you wish to make your own special palette setup.





Use the  or  EXP/VRM key to move the frame to the level to be set.

Each numeral color intensity (R: red, G: green, B: blue) will be displayed on the menu.

Use the  Threshold key to highlight the color to be changed and select the color intensity (1 ~ 15) with the  or  PHASED R. key.

Once the color palette has been set, return to sounder display, which will memorize the color setup in E-1 or E-2.

Use  or  key to return to MAIN MENU.

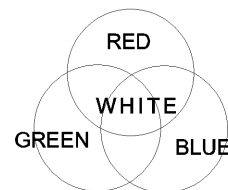

WHAT IS "COLOR PALETTE" ?

There are three basic colors (red, green and blue). Each color has 15 intensity levels. By mixing the different colors and intensity levels the desired color tones may be created for the display.





Palette 1 to 8 can be customized to suit individual needs and wishes.



2. OUTER DEPTH

- ◎ To display the bottom depth in digits by setting this function ON even if the bottom depth is out of the set range.
 - Each press of the  or  PHASED R. Phased range key changes ON with OFF alternately.
- { OFF : No digit depth display in case the bottom depth is out of the range.
 ON : The bottom depth is displayed at the bottom of the screen in digits even if the bottom depth is out of the set range.
 However the processor in the ES-1080 automatically adjusts the transmit pulse rate "MEDIUM" to allow for the longer travel time to the bottom and return.

3. TRIGGER SIGNAL



- ◎ To select where the trigger signal is taken from, either INTRNL or EXTRNL. This function is used when using ES-1080 as a slave display to other sounding equipment.
 - Each press of the  or  PHASED R. Phased range key changes INTRNL with EXTRNL alternately.
- { INTRNL : To select when using only the signal of the ES-1080.
 EXTRNL : To select when using the signal from the external unit.

4. ECHO SIGNAL

- ◎ To select where the echo signal is taken from, either INTRNL or EXTRNL.
 - Each press of the  or  PHASED R. Phased range key changes INTRNL with EXTRNL alternately.
- { INTRNL : To select when using only the signal of the ES-1080.
 EXTRNL : To select when using the signal from the external unit.
- (Select "EXTRNL" when using ES-1080 as a slave display to other sounding equipment.)

5. OUTPUT

⊙ On installing optional kit serial output data is selected in the following sentences.

- By pressing the  or  PHASED R. Phased range key the desired output sentence is selected from the following.

(OFF → 183N → 183T → 600S → OFF)



OFF	: No output
1 8 3 N	: To output data of DBS, DBT, and MTW every 1 second.
1 8 3 T	: To output data of DBT every 1 second.
6 0 0 S	: To output data of depth at transfer rate of 600bps every one second.



NOTE !

- ⊙ DBS : outputs the values for Depth below surface, the values added the draft range. When the draft range is not activated, the same values as DBT are output.
 - ⊙ DBT : outputs the values of Depth below transducer that is not related to the draft range.
 - ⊙ MTW : outputs the values for Water temperature when a temperature sensor is connected.
 - ⊙ Data transfer rate : indicates the data transmitting rate.
-

6. TRANSMIT INTERVAL ADDITION RATE

⊙ The transmit interval rate can be added to eliminate some double echoes.



- Each press of the  or  PHASED R. Phased range key changes the values between 000 and 999.

	: increases the value.
	: decreases the value.

- In the setting values from 0 to 999 the larger values selected, the less double echoes appears on the screen.

7. TRANSMIT RATE (PULSE REPETITION RATE)

⊙ The transmit rate of the sound waves from the transducer can be selected.

• Each press of the  or  PHASED R. key changes the transmit rate.



{ HIGH : can be set the highest rate according to the range.
 MEDIUM : can be set the standard rate according to the range.
 LOW : can be reduced the standard rate by half.

8. PULSE WIDTH

⊙ The transmitted pulse width can be set.

• The transmitted pulse can be set to these kinds (narrow ▪ normal ▪ wide ▪ detail), where the optimum setting will be applied according to the range automatically. Or it can be set manually, if a specific pulse width (0.3 ~ 3.6 msec) is required.

• Select the optimum width of the transmitting pulse by  or  PHASED R. key.

• Each press of  or  PHASED R. key changes the setting.

(NARROW → NORMAL → WIDE → DETAIL → 0.3 → NORMAL)

NORMAL : Setting NORMAL changes the value automatically according to the range. Refer to the list in the next page.



NARROW : When the searching range is short and higher resolution is required, the pulse width should be set NARROW.
Normal pulse width x 0.5



WIDE : The longer range gives less resolution.
Normal pulse width x 1.5

DETAIL : The pulse width changes automatically according to the range and its change is displayed in details.

0.3 : The pulse width is independently of the range in use and its initial value of the pulse width is 0.3 msec.
Refer to the following page.

< TO BE CONTINUED >

- ⊙ By pressing  or  key the pulse width is to be set every 0.1 msec unit from 0.3 to 3.6 msec.

 key: increases the value.
 key: decreases the value.

RANGE DEPTH m	PULSE (m s e c)
0 ~ 50	0.3
~ 100	0.6
~ 240	1.2
~ 640	2.4
641 ~	3.6



(m s e c : 1/1000 SECOND)

NOTE !

- ⊙ In actual practice, the short pulse width gives better detection resolution, and less noise in shallow water. A long pulse will reach deeper but give less resolution.



9. OPERATION MODE

- ⊙ To select one of the Operation modes that was stored in the memory.

- Each press of the  or  PHASED R. key changes 0 with 1 alternately.
- Each of the setting 0 and 1 can store 3 kinds of operation mode you have created, that is, in total 6 kinds of operation mode can be stored in the memory.



10. SHIFT AVERAGE - Scale increment

- ⊙ A different shift can be set for the display in the depth range.

- Each press of the  or  PHASED R. key changes the value, (1 - 5 - 10 - 50 - 100 - 1).
- For example in the SHIFT AR 1, the depth on the screen moves by 1 depth unit and in the SHIFT AR 5 does by 5 depth unit.



11. TEMPERATURE SENSOR



◎ To select one of the interfacing connections for temperature sensor.

- Each press of the  or  PHASED R. Phased range key changes the item,
(OP-102 → OP-41-1 → NMEA-0183 → OP-102).
- To present a temperature via the NMEA-0183 input port, the interface connection should be made to the receptacle on the rear panel of the cabinet.

12. AUTO SHIFT LIMIT

◎ To select the upper limit of the depth value for automatic bottom tracking.





- Each press of the  or  PHASED R. Phased range key changes the depth value by 1 unit between 010 and 999.

 : increases the depth value.
 PHASED R.
 : decreases the depth value.

For AUTO SHIFT info.  Page 74





ALARMS

ALARM	
RETURN MAIN MENU	
SHALLOW	OFF
DEEP	OFF
FISH	OFF
TEMP MAX.	OFF
TEMP MIN.	OFF
TEMP RANGE	OFF



- Use the  or  EXP/VRM key to highlight the item you want to change.
- Use the  or  PHASED R. key to set the desired function ON/OFF or to return to MAIN MENU display when RETURN MAIN MENU highlighted.

1. SHALLOW ALARM

- ☉ To set to sound a "beep" if the echo sounder detects the sea bottom above (shallower than) the set alarm depth.

- Each press of the  or  PHASED R. key alternates OFF with 0000.
- To access the alarm setting and set the value from "0000" into the desired alarm depth value by pressing the  or  key.

The active zone is indicated by a Shallow maker (↕) on the right side of the screen.

-  key : increases the value. (The position of the marker is deeper.)
-  key : decreases the value. (The position of the marker is shallower.)

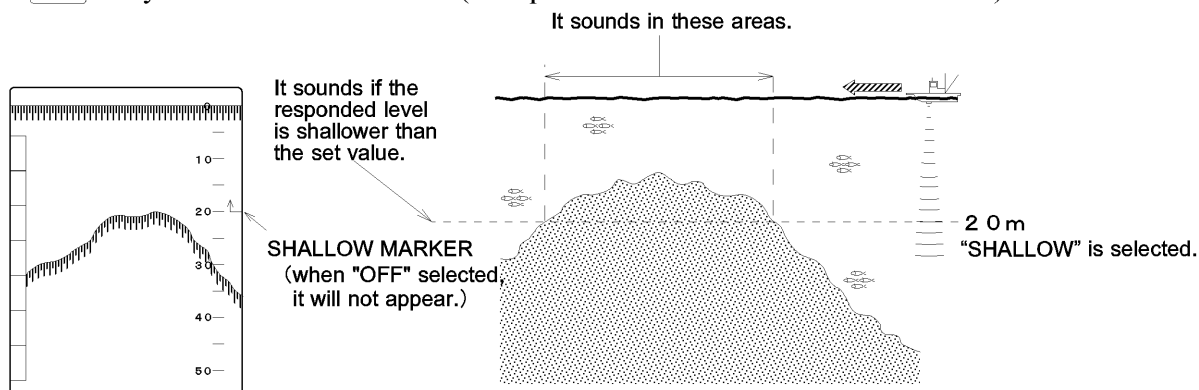





- ☉ Select "OFF" in case of not utilizing the alarm functions.

Refer to the next page for the way of inactivating this function.



2. DEEP ALARM

- ⊙ To set to sound a "beep" if the echo sounder detects the sea bottom below (deeper than) the set alarm depth.

- Each press of the  or  Phased range key alternates OFF with 0000.

- To access the alarm setting and set the value from "0000" into the desired alarm depth value by pressing the  or  key.

The active zone is indicated by a Deep maker () on the right side of the screen.

-  key : increases the value. (The position of the marker is deeper.)
-  key : decreases the value. (The position of the marker is shallower.)

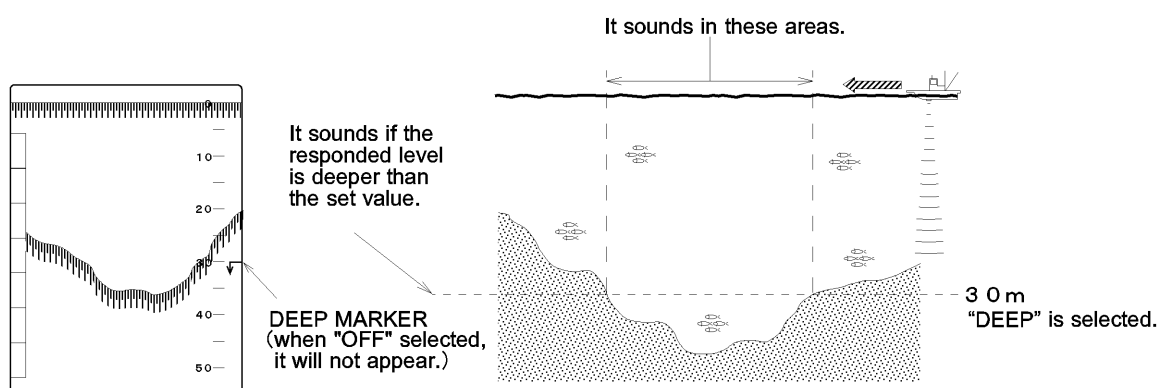

- ⊙ Select "OFF" in case of not utilizing the alarm functions.



How to Inactivate the Alarms

- ⊙ Once the alarm starts to sound, press any key to disable the alarm. Pressing any key will silence the alarm and will not cause a menu change. Note that all keys are inoperative while the alarm sounds.



3. FISH ALARM



- ⊙ The Fish alarm mode will alert you if any object appears between the two set points (Deep alarm and Shallow alarm).

This sets the level of the alarm sounding.

- Each press of the  or  PHASED R. key alternates OFF with 6.

- | | | | |
|--|--------------------------|---|---|
| { | OFF : disable Fish alarm | } | The alarm sounds in relation to the color scale No. |
| | 1 : color scale 1-7 | | |
| | 2 : color scale 2-7 | | |
| | 3 : color scale 3-7 | | |
| | 4 : color scale 4-7 | | |
| | 5 : color scale 5-7 | | |
| | 6 : color scale 6-7 | | |
| 7 : sounds in relation to color scale No.7 | | | |

- The desired level can be selected by pressing the  or  key after entering 6 (initial value).

-  key : increases the value.
-  key : decreases the value.

FOR EXAMPLE

set value - color scale 3

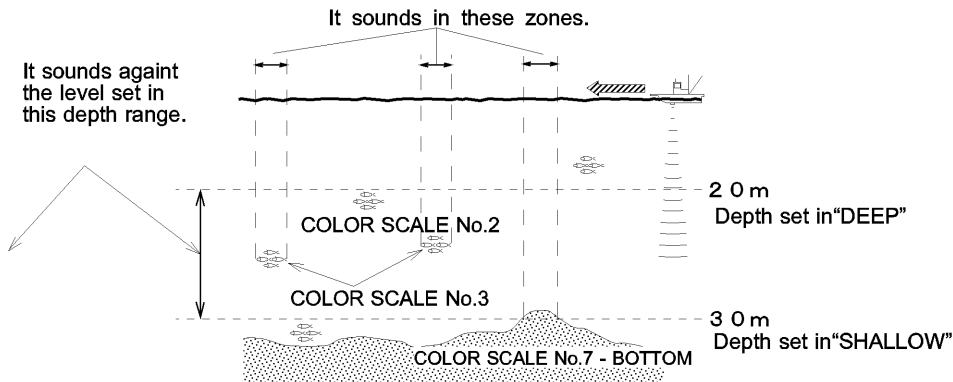
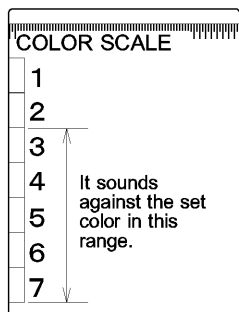

- ⊙ To operate Fish alarm turn both Shallow alarm and Deep alarm OFF after setting both desired alarm depth.

- ⊙ Select "OFF" in case of not utilizing the alarm functions.

How to Inactivate the Alarms







- ⊙ Once the alarm starts to sound, press any key to disable the alarm. Pressing any key will silence the alarm and will not cause a menu change. Note that all keys are inoperative while the alarm sounds.

4. TEMPERATURE MAXIMUM ALARM

- ⊙ The alarm will sound when the water temperature goes above the set degree

that can be set from 0.0 to 35.0 by 0.1 unit (°C) in this case.

An optional temp. sensor is required to activate TEMP MAX alarm.

- Each press of the  or  Phased range key alternates OFF with 35.0.
- The desired value can be selected by pressing the  or  key after entering 35.0 (initial value).
 -  key : increases the value.
 -  key : decreases the value.







- ⊙ Select "OFF" in case of not utilizing the alarm functions.

5. TEMPERATURE MINIMUM ALARM

- ⊙ The alarm will sound when the water temperature goes below the set degree

that can be set from 0.0 to 34.9 by 0.1 unit (°C) in this case.

An optional temp. sensor is required to activate TEMP MIN. alarm.

- Each press of the  or  Phased range key alternates OFF with 00.0.
- The desired level can be selected by pressing the  or  key after entering 00.0 (initial value).
 -  key : increases the value.
 -  key : decreases the value.

- ⊙ Select "OFF" in case of not utilizing the alarm functions.

How to Inactivate the Alarms

- ⊙ Once the alarm starts to sound, press any key to disable the alarm.





Pressing any key will silence the alarm and will not cause a menu change.

Note that all keys are inoperative while the alarm sounds.



6. TEMPERATURE RANGE ALARM

- ⊙ The alarm will sound when the water temperature goes above the set degree the defined changed value compared to the change of the last 1 minute, ranging from 00.0 to 09.8 by 0.1 unit (°C) in this case.

An optional temp. sensor is required to activate TEMP RANGE alarm.

- Each press of the  or  PHASED R. Phased range key alternates OFF with 00.0.
- The desired level can be selected by pressing the  or  key.

after entering 00.0 (initial value).

-  key : increases the value.
-  key : decreases the value.

- ⊙ Select "OFF" in case of not utilizing the alarm functions.

How to Inactivate the Alarms

- ⊙ Once the alarm starts to sound, press any key to disable the alarm.

Pressing any key will silence the alarm and will not cause a menu change.

Note that all keys are inoperative while the alarm sounds.





TR/RX MENU

- © When using the ES-1080 equipped with the TR/RX board (NO.719), TR/RX MENU may be adjusted as below.
- Note that the TR/RX MENU has not set up under the factory setting and the following message appears when turning on the power of the unit.

The TR/RX MENU has not set up.
Call up "MAIN MENU - TR/RX MENU" display to set TR/RX MENU.

- While appearing this message, the settings can not be changed as TX POWER "LOW" (PWR-LOW on the screen) is selected.
- After the below setting via the "TR/RX MENU" is completed, this message will not appear and then "MAIN MENU - FUNCTION SET - TX POWER" starts to be available. Check the transducer connector has been wired properly.

TR / RX MENU	
<u>RETURN MAIN MENU</u>	
TRANSDUCER	200k 50 ϕ x1
FREQUENCY	200kHz
TR FREQUENCY	200.000
RX FREQUENCY	200.000
BAND WIDTH	WIDE
JUMPER SET	A

- Use the  or  EXP/VRM key to highlight the item you want to change.
- Use the  or  PHASED R. key to set the desired function or to return to MAIN MENU display when RETURN MAIN MENU highlighted.



※ Note 1): The above item will not appear when the TR/RX board other than No.719 board is equipped.

Note 2): The above indication, JUMPER SET A is not effective until the jumper setting (refer to the page 58) is completed.

※ Refer to the next pages for the details of this function.

1. TRANSDUCER



⊙ To select the transducer connected to the ES-1080.

- Press  or  Phased rangekey to select the desired transducer from the registered transducers.

If you can not find the transducer you need, select "OTHERS".

2. FREQUENCY



⊙ Select the nearest frequency you need when "OTHERS" in the above item 1. TRANSDUCER is selected. This setting is not required when one of the registered transducers is selected in the item "TRANSDUCER".



- Each press of  or  Phased range key changes the frequency in order.

3. TR FREQUENCY

⊙ The transmitting frequency for the transducer is adjusted by this setting.

- It displays the transmitting frequency (corrected value) that is selected in the item 1 "TRANSDUCER" or in the item 2 "FREQUENCY".
- This function adjusts the difference between the frequency selected in the above and the desired frequency.





- Press  or  Phased range key to set appropriate value in the setting.

 : increases the values.
 : decreases the values.



⊙ The appropriate transmitting frequency can be adjusted here while watching the picture. Change also the TR frequency when the RX frequency explained in the next page is changed for avoiding the interference.

- The frequency adjusted here will be cleared when the setting of "TRANSDUCER" or "FREQUENCY" is changed.

4. RX FREQUENCY

- ⊙ The receiving frequency for the transducer is adjusted by this setting.
 - It displays the receiving frequency (corrected value) that is selected in the item 1 "TRANSDUCER" or in the item 2 "FREQUENCY".
 - This adjusts the difference between the frequency selected in the above and the desired frequency. The correction can be set every 1kHz.
 - Press  or  Phased range key to set appropriate value in the setting.
 -  : increases the values.
 -  : decreases the values.
- ⊙ The appropriate receiving frequency can be adjusted here while watching the picture. Change the RX frequency to avoid the interference, if required.
 - The frequency adjusted here will be cleared when the setting of "TRANSDUCER" or "FREQUENCY" is changed.

5. BAND WIDTH

- ⊙ To set amplifier band width of frequency RX amplifier.
 - Each press of  or  Phased range key changes the width, "NARROW - WIDE - NARROW".
 - When NARROW is chosen, the noise suppression is greater however resolution in shallow water is lower. For increased resolution, select WIDE.

6. JUMPER SETTING

- ⊙ The current "JUMPER SET" appears just below "TR/RX MENU" on the screen after selecting one of the registered transducers from "TRANSDUCER". However it will not appear when "TRANSDUCER - OTHERS" selected.

- One of the following, "A, B, C, D, E or J12" appear on the screen.

Set the necessary jumper according to the sign displayed on the screen.

When "J12" is displayed on the screen, add a jumper in the accessory box of the main unit.

- In case of connecting a transducer other than the registered one, please contact your nearest Suzuki dealer.

- ⊙ The ES-1080 must be turned off and disconnecting the power cables while setting the jumper.

- How to set the jumpers on TR/RX board.

- Remove 4 screws on the blind (in the fig.1) of the rear panel.

- The jumper terminals (from A to E), a jumper plug and the jumper terminal J12 can be seen as shown in the Fig.2.

- Pull this jumper plug out from the board and insert it into the terminal indicated on the screen. Note that the plug side for A-E is different from J12 when inserting the terminal on the board.

- Put the blind back after setting the necessary jumper.

Fig. 1

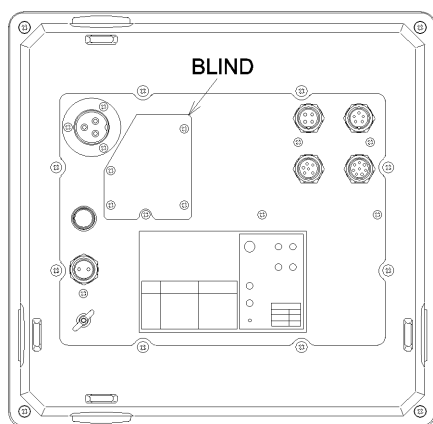
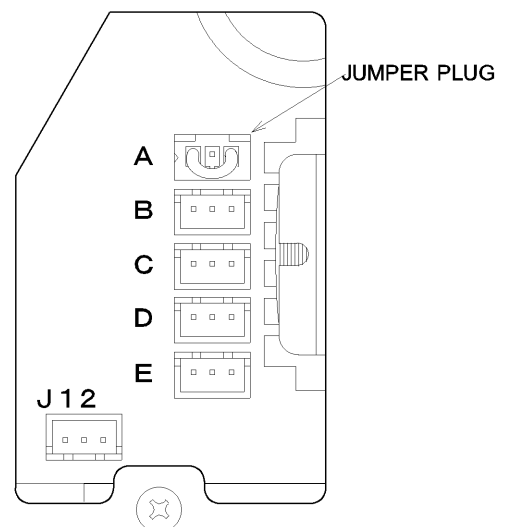

Fig. 2



FUNCTION DIALS AND KEYS

This chapter provides you the explanation for function dials and keys.

DIAL OPERATION	MODE SELECTION DIAL -----	60
	1. NORMAL MODE -----	61
	2. BOTTOM EXPANSION MODE -----	61
	3. PARTIAL EXPANSION MODE -----	62
	4. NAVIGATION DISPLAY MODE -----	62
	5. MENU 1 (RANGE SET) -----	63
	6. MENU 2 (FUNCTION SET) -----	63
	RANGE DIAL -----	64
	EXPANSION RANGE DIAL -----	64
	GAIN DIAL -----	65
	FAR GAIN DIAL	
	1. TVG -----	66
	2. STC -----	67
	BRIGHTNESS DIAL -----	67
KEY OPERATION	OPERATION MODE KEYS -----	68
	EXPANSION/VRM KEYS	
	1. EXPANSION START POINT -----	69
	2. VRM -----	69
	MEMORY WRITE / READ KEY -----	70
	PHASED RANGE KEYS -----	70
	MARK KEY	
	1. MARK -----	71
	2. TIMER -----	71
	PICTURE SPEED KEY -----	72
	THRESHOLD KEY -----	73
AUTO RANGE	AUTO RANGE FUNCTION -----	74
/ AUTO SHIFT	AUTO SHIFT FUNCTION -----	74

CONTROL DIALS

MODE SELECTION DIAL

☉ You can select an appropriate display mode.

- MENU 1 and 2 can be used to set the basic functions on the ES-1080.
- The following displays differ depending on the function set by "SCREEN DIVISION". The below figures show the samples of vertical division.

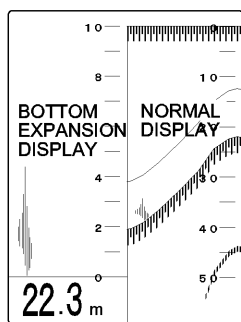

NORMAL DISPLAY & BOTTOM EXPANSION DISPLAY

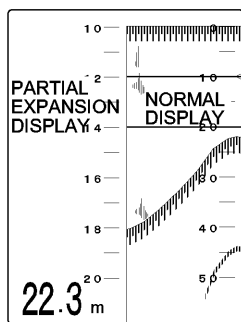

NORMAL DISPLAY & PARTIAL EXPANSION DISPLAY

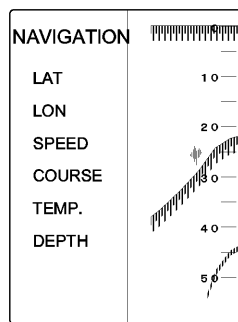

NORMAL DISPLAY & NAVIGATION DISPLAY

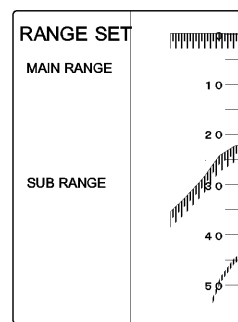

RANGE SETTING DISPLAY

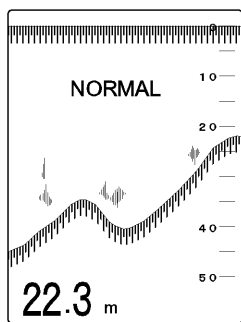

NORMAL FULL DISPLAY

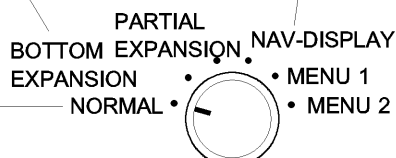

MODE SELECTION DIAL

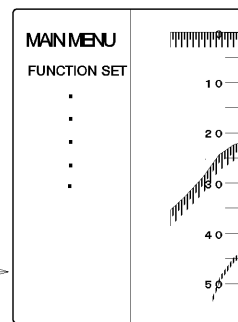

FUNCTION SETTING MENU

* For more detailed explanation for each mode, refer to the following pages.

1. NORMAL MODE

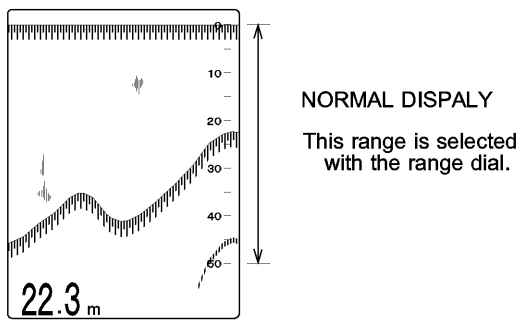

Normal sounder display mode on the full screen.

2. BOTTOM EXPANSION MODE

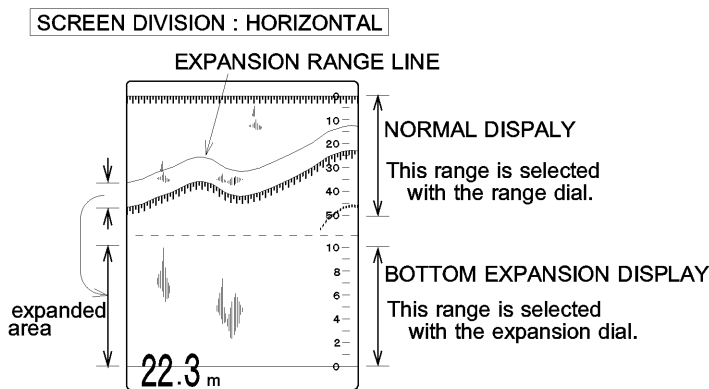

Screen division may be set on the Menu 2 function setting menu display.

Under screen division HORIZONTAL setting Normal mode is displayed on the upper half of the screen. Bottom expansion mode is displayed on the lower half.

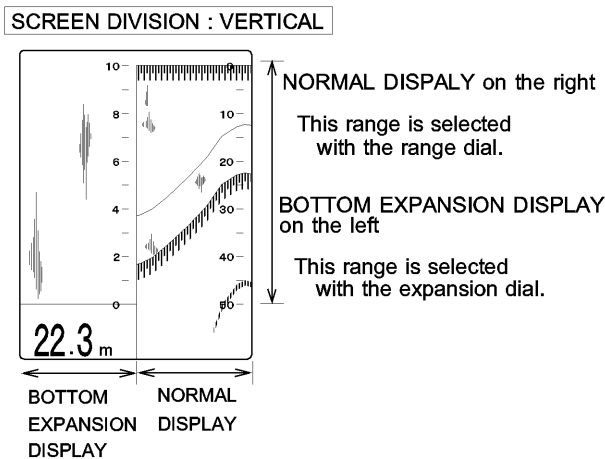

The expansion range line is indicated by a line on the Normal mode.

The expansion range may be selected with the expansion dial.

Under screen division VERTICAL setting Normal mode is displayed on the right side of the screen. Bottom expansion mode is displayed on the left side.

Note that the expansion range line is not displayed on the screen when "SCREEN DIVISION- BTM EXPN - AUTO" selected.

3.PARTIAL EXPANSION MODE

SCREEN DIVISION : HORIZONTAL

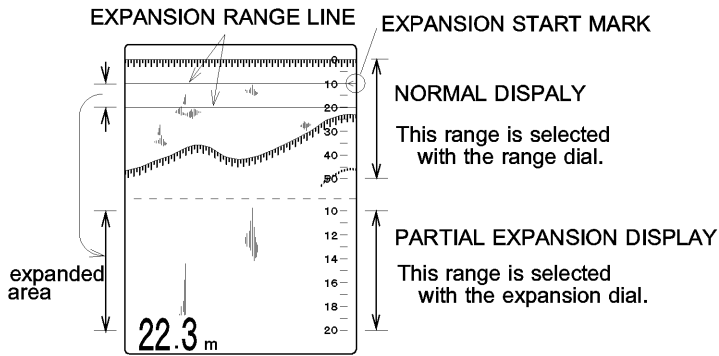

- ⊙ Screen division may be set on the Menu 2 function setting menu display.
- Under screen division HORIZONTAL setting Normal mode is displayed on the upper half of the screen. Partial expansion mode is displayed on the lower half.
- The expansion range line is indicated by two lines on the Normal mode.

SCREEN DIVISION : VERTICAL

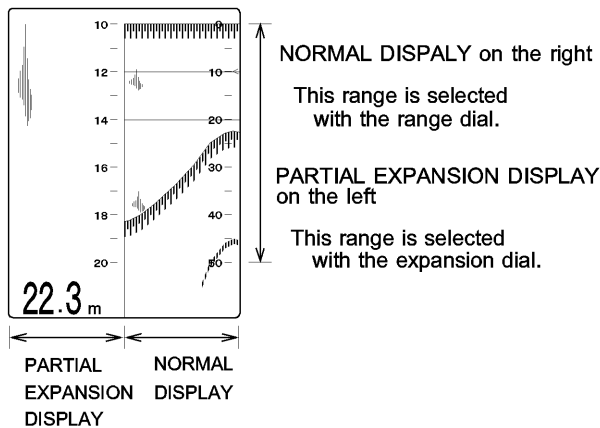

- The expansion range may be selected with the expansion dial.
- Under screen division VERTICAL setting Normal mode is displayed on the right side of the screen. Partial expansion mode is displayed on the left side.

4.NAVIGATION (DATA) DISPLAY MODE

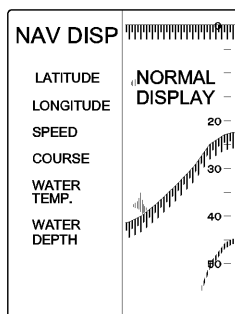

- ⊙ Sounder normal mode is displayed on the right half of the screen. Navigation data is displayed on the left half of the screen.

NOTE !

- ⊙ Navigation data is only available when ES-1080 is connected to an optional equipment.
- ⊙ Water temperature data is only available when the ES-1080 is connected to an optional water temperature sensor.

5. MENU 1 (RANGE SETTINGS)

- ◎ To display the RANGE SET MENU.
- To customized the ranges of the range dial, set desired ranges with "RANGE SET MENU" before operating this unit. **cf** Page 19/20

RANGE SET	
MAIN RANGE NUMBER	RANGE DEPTH
1	0 0 0 — 0 0 2 5
2	0 0 0 — 0 0 5 0
3	0 0 0 — 0 1 0 0
4	0 0 0 — 0 1 5 0
5	0 0 0 — 0 2 0 0
6	0 0 0 — 0 3 0 0
7	0 0 0 — 0 5 0 0
EXPANSION RANGE	
NUMBER	RANGE DEPTH
1	0 0 0 1
2	0 0 0 2
3	0 0 0 5
4	0 0 1 0
5	0 0 2 0
6	0 0 3 0
7	0 0 4 0
8	0 0 5 0

6. MENU 2 (FUNCTION SETTINGS)

- ◎ To display the FUNCTION SET MENU.
- To set up a fundamental function.
- To customized the functions, set desired functions with "FUNCTION SET MENU" before operating this unit. **cf** page 21

MAIN MENU
FUNCTION SET
REDUCTION
SCREEN DIVISION
DISP ITEM SEL
UNIT · ADJUST
OTHERS
ALARM
TR/RX MENU

RANGE DIAL

- ⊙ Range dial allows the user to set the displayed depth range to begin at some point below the surface.

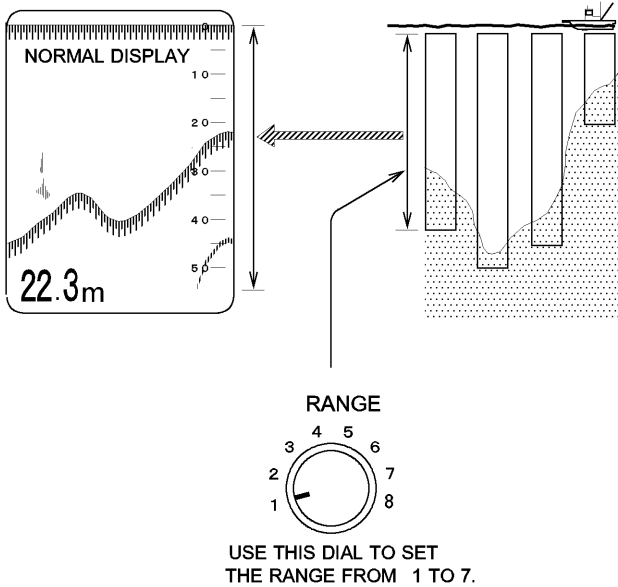

- Factory setting range

1 :	2 5
2 :	5 0
3 :	1 0 0
4 :	1 5 0
5 :	2 0 0
6 :	3 0 0
7 :	5 0 0
8 :	A U T O

- how to choose : **cf** page 19 the desired range
- No.8 / AUTO RANGE : **cf** page 74

EXPANSION RANGE DIAL

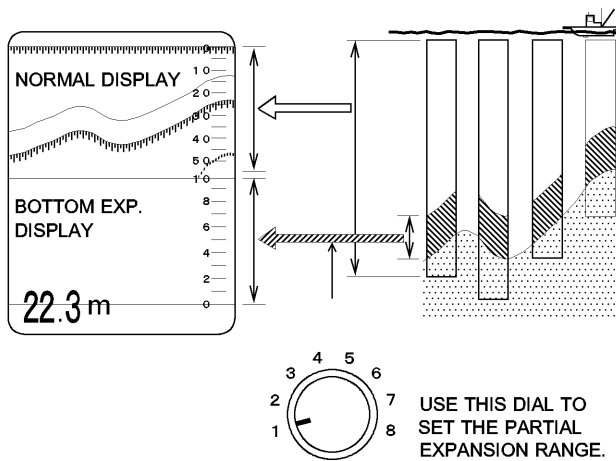

- ⊙ This function allows you to take a closer look at a particular section of the water underneath your boat. You can expand the view near the bottom or select the partial expansion range.

- The expansion range

1 :	1
2 :	2
3 :	5
4 :	1 0
5 :	2 0
6 :	3 0
7 :	4 0
8 :	5 0

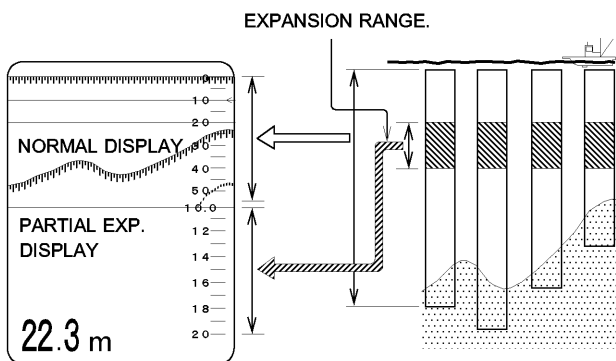

- The amount of expansion can be adjusted.
- how to choose : **cf** page 20 the desired range

GAIN DIAL

- ⊙ To adjust the level of sensitivity of the received echo signal.
 - Turning the dial clockwise increases the gain level, keep turning the dial until the sea bottom is shown in red.

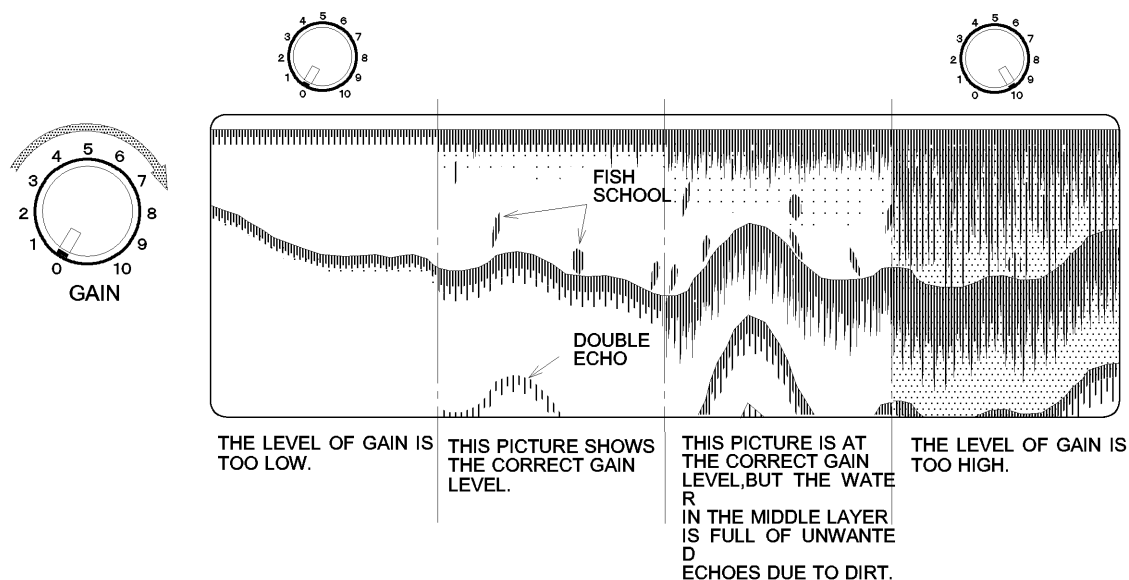

- The strongest echoes are displayed in red and as the received echoes get weaker they are indicated as follows; red → orange → yellow → green → light green → blue → light blue.
- When the target is the sea bottom the gain level setting can be low because the echo from the sea bottom is very strong. However, when the target is fish the level of gain must be increased to pick up the weaker echo. Increasing the gain too much will display unwanted echoes from bubbles and plankton etc.
- If the sea bottom echo is weak due to seaweed, mud etc. adjust the gain level to pick up the weaker echo.
- When passing over the transducer face, bubbles reflect the sound wave and appear as echoes on the screen. In this case, no echoes (fish school) may be displayed even though at a maximum gain level.

NOTE !

- ⊙ The Settings above can be entered from MENU 2 - FUNCTION SET - GAIN UP".

FAR GAIN DIAL

☉ To adjust the level of TVG curve or STC selected in the function set.

cf Page 23

1. Selection of TVG CURVE (1 ~ 4)

☉ To control the level of the sensitivity of the received deep echo signal.

- Turning the dial clockwise does not increase the gain level close to the transducer but increases the gain level as the depth increases.
- For further true display, it corrects the display differences between the shallow echo and the deep echo.
- The sensitivity achieved using this dial influences the sensitivity achieved using the GAIN DIAL and TVG CURVE function on FUNCTION SET MENU. **cf** Page 23/65

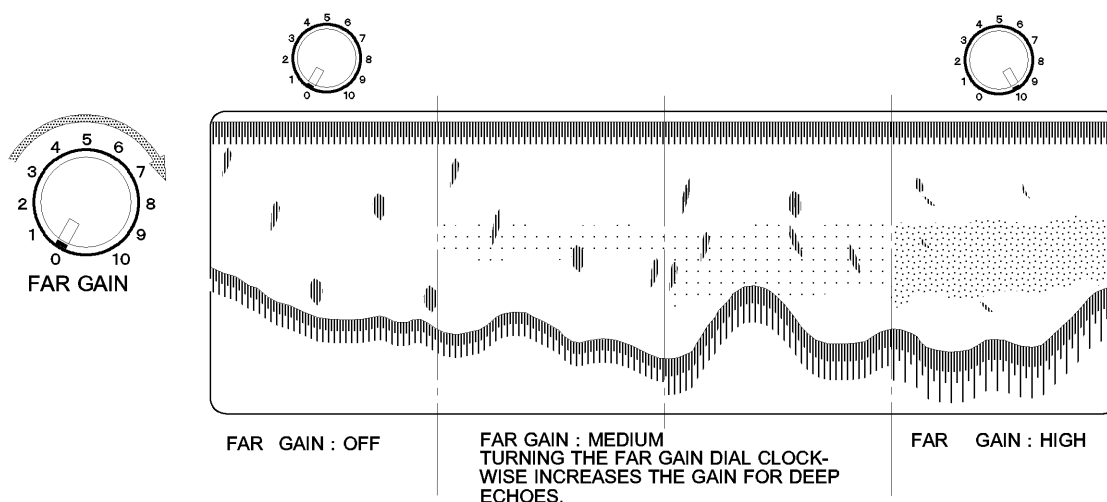

WHAT IS "FAR GAIN"?

- ☉ The power of the sound wave is absorbed at a certain rate when travel through the water. The higher the frequency, the higher the rate of absorption. For example after travelling 1 kilometer the power of a 50kHz sound wave will decrease to 1/8 of its original strength. The power of a 200kHz sound wave will decrease to 1/300 of its original strength. Use this FAR GAIN dial to counteract the absorption effect by increasing received echo signal of deep echoes.

2. Selection of " STC - Sensitivity Time Control ".

- ⊙ To reduce receiver gain for shallow water echoes and restores it with depth in such a manner as to equalize echo strengths at different depths.
- This initial gain suppression is at maximum in the fully counterclockwise position.
- Use this function effectively by adjusting gain value and GAIN UP function.

cf Page 23/65

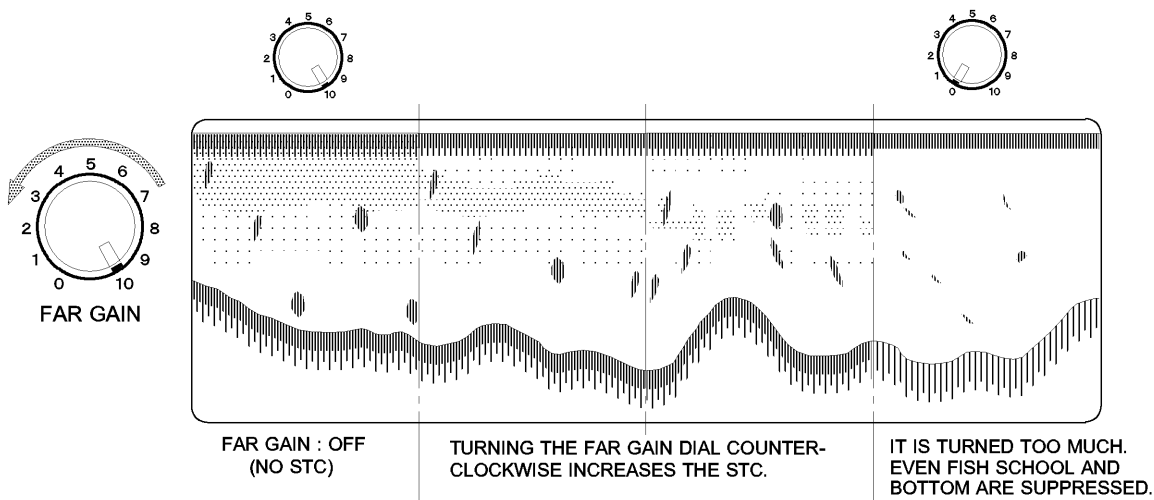

- ⊙ In case of using FAR GAIN DIAL as STC function there is no effect at the dial 10 and increase the effect as turning the dial into the dial 0.

At this time turning too much to counterclockwise suppresses even fish school or bottom signal.

BRIGHTNESS DIAL

- ⊙ To turn the power on by turning the dial clockwise.

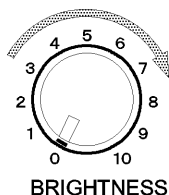

Further turning in a clockwise direction increases screen brightness.

KEY OPERATION

OPERATION MODE KEYS

- ⊙ Use these keys to select one of the 3 kinds (in total 6 kinds by using MENU 2 - OTHERS) of operation mode you have created. **cf** Page 48

Press one of these keys after its registration so that the desired operation mode can be available immediately.

- Previously set each desired function on MENU 2 and close it when registering operation mode key numbers.
- By holding one of the **1** (**2** · **3**) keys for 2 seconds until a beep sounds, all functions set currently are memorized. If the key is released before a beep sounds, nothing can be memorized.
- Press appropriate OPERATION MODE KEY until a beep sounds to activate this function. 3 beep-sounds indicates that nothing has memorized and changed.
- During the operation by one of the operation modes the settings can be changed and activated the changed settings, however pressing one of the operation keys again returns to the previous operation mode.
To register the changed setting, hold the operation mode key for 2 seconds.
- The activating operation mode key number appears at the top of the screen depending on key pressed. Nothing appears when the operation mode is not registered.

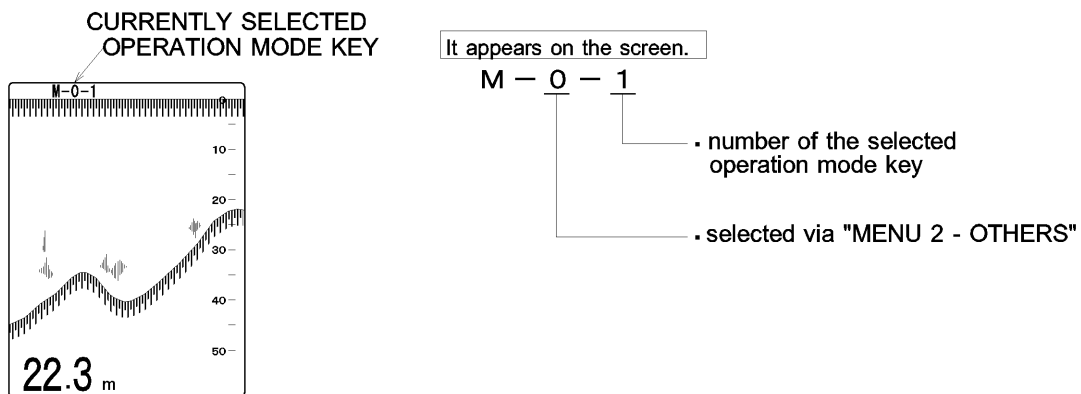

EXPANSION/VRM KEYS

- ⊙ To active the settings adjusted in "MENU 2 - DISP ITEM SEL - EXP/VRM" .

cf page 32

1. EXPANSION START POINT

- ⊙ To set the expansion start point for Partial expansion mode.

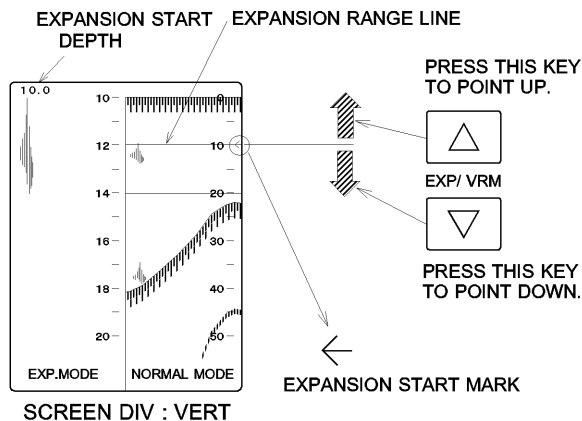



- The numeral expansion start depth will be displayed on the upper left corner of the screen.

2. VRM LINE

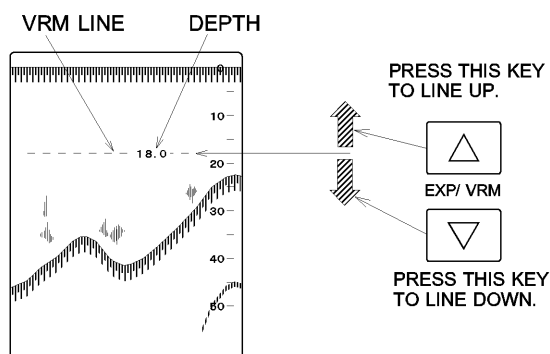
- ⊙ If you want to monitor a particular depth in greater detail then the marker line is a very convenient method. It also allows you to change the depth monitored merely by changing the marker line position.



- Its depth value is presented on the right side of the line.
- Pressing both  and  EXP/VRM keys at the same time alternates VRM line on with off.

MEMORY WRITE/READ KEY

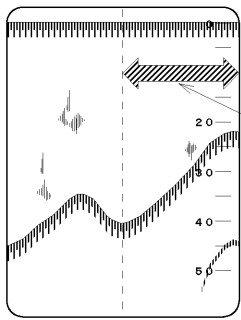

PRESS THIS KEY TO MEMORIZE THIS HALF OF THE SCREEN.



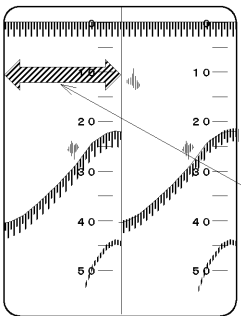

MEMORY WRITE KEY



WHEN THIS KEY IS PRESSED, THE MEMORIZED DATA WILL BE DISPLAYED HERE.



MEMORY READ KEY

- ⊙ To memorize the right half of the screen.
 - Each press of the memory write key  will memorize the right half of the screen, erasing the previously memorized data.
- ⊙ To display the memorized data above.
 - Pressing the memory read key  will display the above memorized data on the left half of the screen.
 - When the memory read key  is pressed again the data will be erased from the screen.



- ⊙ The memorized data will be erased when the power is turned off.

PHASED RANGE KEYS

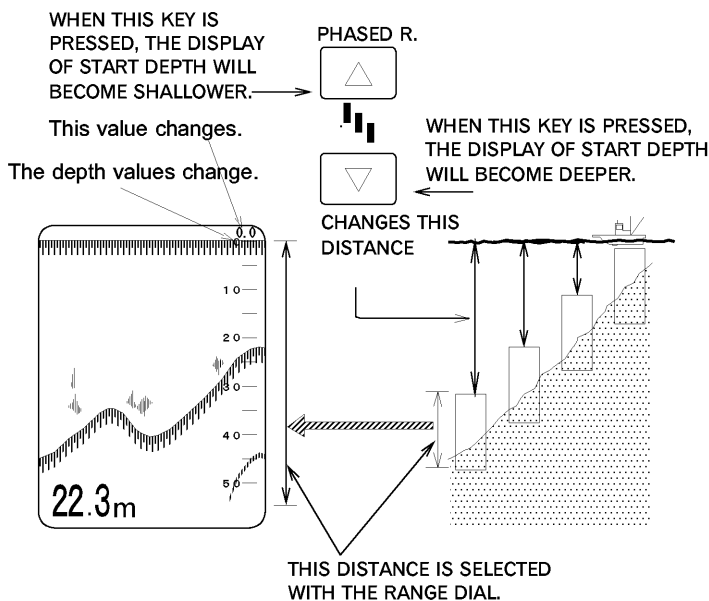

- ⊙ For the selection of the depth start point at the top of the screen.
 - The range can be selected by "MENU 2 - OTHERS - SHIFT AVERAGE". **cf** Page 48
 - Phased range is available in 1 unit step (0 to 999).
 - This function may be used to show the desired area expanded on the screen.
 - AUTO SHIFT **cf** Page 74

MARK KEY

⊙ Select "MARK" from "MENU 2 - DIS ITEM SEL.-MARK" to active this function.

cf Page 36

1. MARK

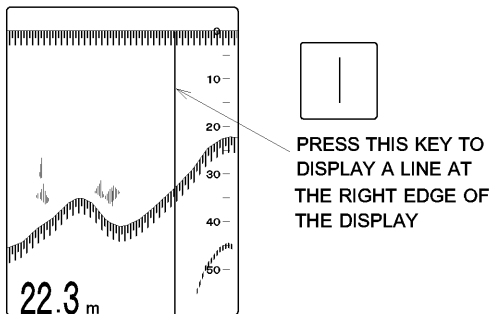



⊙ To mark a line on the display.

- Pressing this key  will set a yellow vertical line at the right edge of the display.

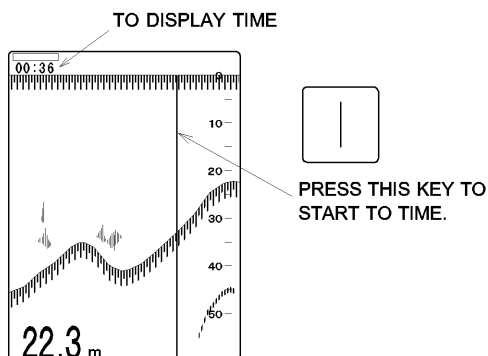
2. TIMER



⊙ To time between the two lines.

- Pressing this key  will start to time.
- The second press of this key  will stop timing.
- The third press of this key  will erase the digital display of timer from the screen.

PICTURE SPEED KEY

◎ The picture speed rate may be changed.

- Each press of  key changes the setting as follows.

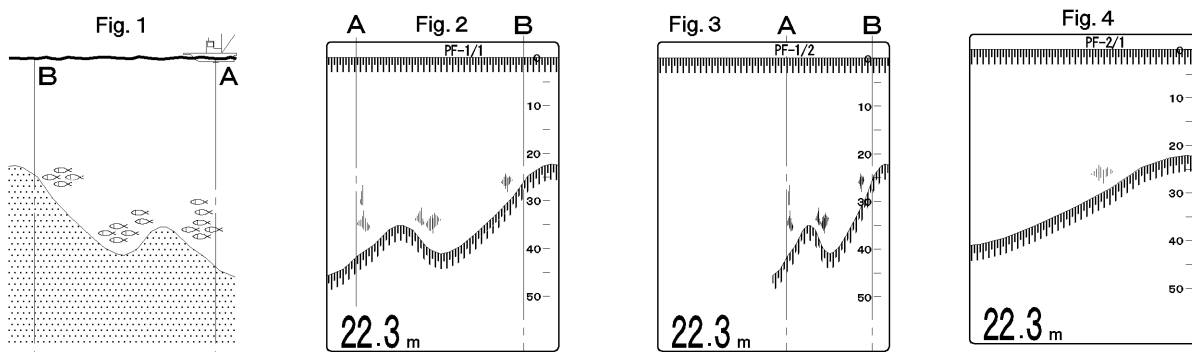
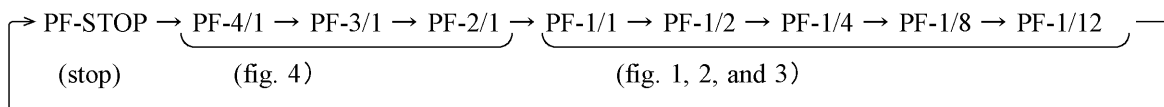

- [Selection of PF 1/1 ~ PF 1/12]

As you see in the Fig.1 the ship travels from point A to B. In case of the higher rate of movement of the targets on the display screen, moving from right to left, it will be adjusted like Fig.2. and in case of the lower rate of movement of the targets on the display screen, it will be adjusted like Fig.3.

- [Selection of PF 2/1 ~ PF 4/1]

In case of the higher rate of movement than PF 1/1, the expanded picture will be displayed as you see in Fig.4.

WHAT IS PICTURE SPEED ?

- ◎ Picture speed rate refers to the speed the picture travels from right to left on the screen. 1/1 refers to 1 vertical line of picture per 1 sound transmission, and 1/2 refers to 1 vertical line of picture per 2 sound transmissions. Furthermore 2/1 refers to 2 vertical lines of picture per 1 sound transmission, and 4/1 refers to 4 vertical lines of picture per 1 sound transmission.

There is no relation to ship speed.

THRESHOLD KEY

- ⊙ To remove and recall weaker echoes by color scale from the screen.
 - Each time this key  is pressed the weakest color will be erased.

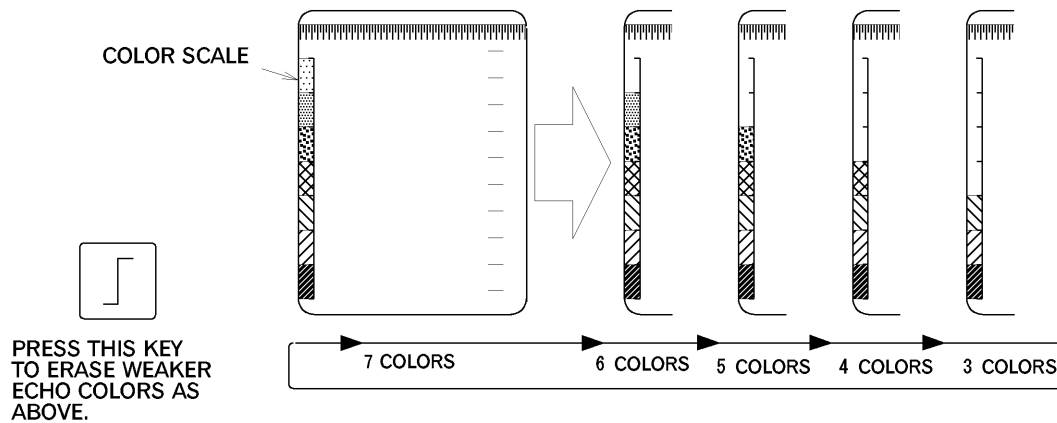

WHAT IS THRESHOLD ?

- ⊙ The equipment will pick up and display unwanted echoes from small objects in the water. With the threshold function it is possible to eliminate these unwanted echoes from the screen.

AUTO RANGE / AUTO SHIFT

AUTO RANGE FUNCTION

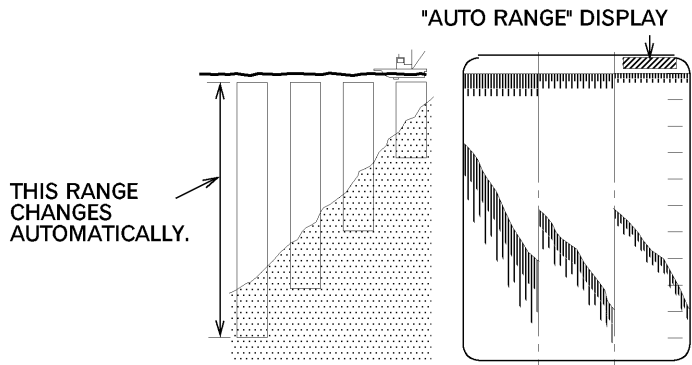

- ⊙ The range will change automatically to always show the full depth from transducer face to sea bottom regardless of changes in depth.



- Select 8 (AUTO) on the range dial to start the auto range function.
- When this function is activated, "AUTO RANGE" will be displayed in the right of the top screen.

AUTO SHIFT FUNCTION

- ⊙ The phased range will change automatically to always track the bottom in the specified range.

- Press both  and  Phased range keys at the same time to start the auto shift function. When this function is activated, "AUTO SHIFT" will be displayed in the right of the top screen.
- Pressing either one of the phased range keys cancels this function.

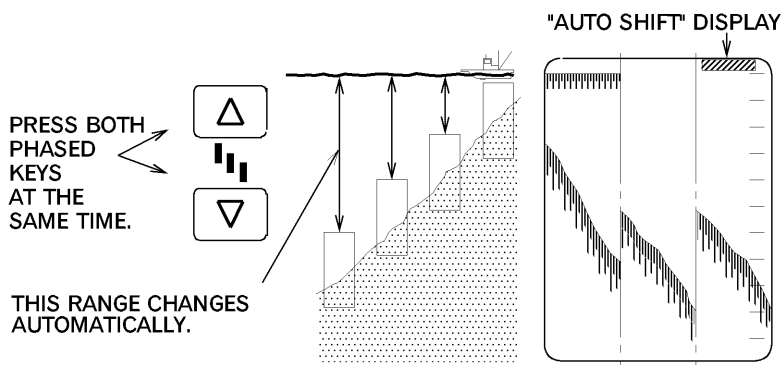

NOTE !

- ⊙ For auto range and auto shift functions to work successfully, the sea bottom echo must be in red or orange which are the strongest scale colors.
- ⊙ Even when the sea bottom echo is in red or orange, if there is interference due to bubbles etc., the function may not be able to track the bottom. In this case, if the bottom is not located after 16 transmissions, the depth scale will return to 0 and start searching again. If the function is unable to locate the bottom the scale will continue to fluctuate.

SPECIFICATIONS

SPECIFICATIONS - 1

- | | |
|-------------------------------------|--|
| 1. RANGE | 7 ranges available
(setting ranges up to 3000m, fm, br or up to 6000ft) |
| 2. PHASED RANGE | 0 ~ 999 m, fm, br, 0 ~ 2999 ft
(selectable shift range) |
| 3. BOTTOM /
PARTIAL
EXPANSION | 8 ranges available
(setting ranges up to 250m, fm, br or up to 500ft) |
| 4. FREQUENCY
(Single frequency) | 20, 24, 28, 38, 40, 45, 50, 60, 70, 75, 80, 150 or 200kHz |
| 5. DISPLAY MODES | Normal Display mode
Normal/Bottom Expansion Display mode
Normal/Partial Expansion Display mode
Navigation/Normal Display mode
+A-scope, +Color palette, +Range setting mode |
| 6. DISPLAY DATA | Depth Scale, Depth, Water Temp. Scale,
Water Temp. *, Expansion Start Point, Latitude/Longitude *,
Ship's Speed *, Course *, Timer |
| 7. FUNCTION SET
DISPLAY | Picture Speed, Interference Reduction, Auto Shift, Auto Range
Operation Mode |
| 8. ADDITIONAL
DISPLAY | Second Interval Mark (30 seconds intervals)
Color Scale, Water Temp. Graph *, Marker line, Expansion Range
Line, Expansion Start Mark, TX Power |
| 9. ADDITIONAL
FUNCTIONS | Operation Mode, Gain Adjustment, TVG Adjustment, Far Gain, STC
Interference Reduction, Jamming Reduction, Noise Reduction
White Line, Clutter, Dynamic Range, Threshold Key, Auto Range
Auto Shift, Transmit Interval Addition Rate, Scale Position
Depth Grid, Draft Adjustment, Water Temp. Adjustment
Outer Depth, Pulse Selection, Memory Write/Read Keys
Stop Watch function, TX Power, Expansion mode (4 modes),
Depth Display Position, Temperature Display Position, User settings
Color Selection (8 Fix Color setup + Color Palette 2 Color setup)
Temp. Alarm (Shallow/Deep/Fish), Backup function |

SPECIFICATIONS - 2

- | | |
|-----------------------------|--|
| 1. DISPLAY UNIT | 10.4 inch TFT color LCD (640 x 480 pixels) |
| 2. POWER SUPPLY | voltage DC10.5 ~ 40V, Maximum power consumption 45W |
| 3. INTERFACE
Input Data | Water Temp. Sensor (OP-102 or OP-41-1) *,
Temp. Data (NMEA-0183), Navigator (NMEA-0183), External Sounder |
| 4. INTERFACE
Output Data | Depth and Temp. Data (NMEA 0183)*, External Sounder |
| 5. WEIGHT | 6 kg (BRACKET INCLUDED) |

NOTE: * shows optional equipment required.

