



COLOR LCD SEARCHLIGHT SONAR

S-1400 II

OPERATION MANUAL

SUZUKI FISH FINDER CO., LTD.

12-1 MAMIZUKA, TOYOHASHI
AICHI 441-8007, JAPAN

PHONE: (81) 532-32-7511 FAX: (81) 532-32-7500
E-mail address: sales@suzukiff.co.jp URL: <http://www.suzukiff.co.jp/>

INTRODUCTION



Thank you for purchasing the S-1400 II Searchlight Sonar. We are confident you will enjoy using your unit for many years to come.

This manual provides complete information on safely operating the S-1400 II. Please carefully read and follow the safety information so that the S-1400 II will perform to the utmost of its ability.

SAFETY INSTRUCTION

SYMBOLS

- The following symbols are used in this manual.
- Please read this manual carefully and take note of these symbols.

 DANGER	:	indicates an imminently hazardous situation which, if not avoided, will result in death or serious injury.
 WARNING	:	indicates a potentially hazardous situation which, if not avoided, could result in death or serious injury.
 CAUTION	:	indicates a potentially hazardous situation which, if not avoided, may result in minor injury.
NOTE !	:	Indicates the contents for the user's reference.
CF	:	Pages for the user's reference.

NOTICE

- This manual should be kept on hand to provide your quick reference whenever you need it.
- Any use other than that mentioned in this manual is not guaranteed.
- The contents of this manual and equipment specifications are subject to change without notice.
- No part of this manual may be copied or reproduced without written permission.

INSTALLATION SITE REQUIREMENTS



Keep the unit away from the flammable gas.
Otherwise it causes a fire.



Follow the below proposed conditions for the installation.
Otherwise it causes a fire or an electrical shock.

Away as much as possible from areas where the unit is likely to be exposed to direct water spray and free as much as possible from shocks and engine vibration.

Away as much as possible from areas of high temperatures or areas where the unit is likely to be exposed to direct sunlight.

MOUNTING CONDITIONS



Do not install the S-1400 II on unstable or uneven surfaces.
Installing the unit tentatively may result in dropping, toppling over or injury.

Follow the below conditions for wirings.
Otherwise it causes heat, a fire or injury.
Run the cables not to touch the rotary obstacles or disturb the operation.
Do not use the cables bent, twisted or stretched by force.
Do not put heavy objects on the cables.



Always turn off the power before connecting or disconnecting the unit.
Pulling the cables may damage the cables themselves and result in fire or electrical shock.

POWER SUPPLY



Operating voltage: 20 to 31.2 volts DC.
Use the proper voltage. Otherwise it will result in fire or electrical shock.



Turn on/off the power by ON/OFF keys on the control panel.
Turning on/off the power by the switchboard may damage the unit.

Turn off the power when starting the vessel engine.
Otherwise it may damage the unit.

FOR YOUR SAFETY

HANDLING



Do not operate the unit while steering.
Otherwise it will cause wrecks.

Do not open the case cover.
There is a risk of electrical shock if you touch the high voltage conductors.
Only qualified personnel should work inside the unit.

Care for sufficient reinforcement and being watertight should be taken when installing the hoist.
Otherwise it will cause wrecks.



Use the proper fuse when changed.
Otherwise it could result in serious trouble or fire.

Use the specified power supply cables.
Otherwise it could result in serious trouble or fire.

The Hoist Gears and Flange Unit need a regular lubrication with grease.

TFT LCD

The high quality TFT (Thin Film Transistor) LCD displays 99.99% of its picture elements. The remaining 0.01% may drop out or light, however this is an inherent property of the LCD; it is not a sign of malfunction.





CONTENTS



INTRODUCTION	1
SAFETY INSTRUCTION	2
FOR YOUR SAFETY	3
CONTENTS	5
COMPONENTS	7
CHAPTER 1 SONAR SYSTEM SUMMARY	1 - 1
Sonar Mode.....	1 - 2
Tilt Angle.....	1 - 4
Tilt Angle and Display.....	1 - 5
Bottom Scan Mode.....	1 - 6
Echo Sounder Mode.....	1 - 7
Sample Display of Sonar Mode.....	1 - 8
Sample Display of Bottom Scan Mode.....	1 - 8
Sample Display of Echo Sounder Mode.....	1 - 9
CHAPTER 2 SONAR OPERATION	2 - 1
Operation Panel.....	2 - 2
Operation Keys	
Power ON/OFF Key.....	2 - 3
Sensor Lamp.....	2 - 3
Hoist Keys.....	2 - 3
Sonar Mode Key.....	2 - 4
Off Center Mode Key.....	2 - 4
Bottom Scan / Echo Sounder Mode Key.....	2 - 4
Bearing Keys.....	2 - 5
Tilt keys.....	2 - 6
Sector Keys.....	2 - 8
Range Keys.....	2 - 9
Operation Mode Keys.....	2 - 10
Cursor Keys.....	2 - 11
Target Lock Key.....	2 - 13
Threshold key.....	2 - 13
Menu Key.....	2 - 14
Enter Key.....	2 - 14
Operation Dials	
Brightness Dial.....	2 - 15
Gain Dial.....	2 - 15
Far Gain Dial.....	2 - 15
CHAPTER 3 FUNCTION SETTINGS	3 - 1
Initial Settings	
Factor Settings.....	3 - 2
Return to Factory Settings.....	3 - 3
User Settings.....	3 - 3
Menu	
Function Set Menu.....	3 - 4

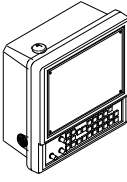
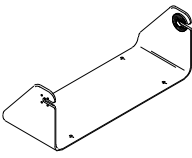

Function settings.....		3 - 5
Setting Functions	Gain Up.....	3 - 6
	TVG Curve.....	3 - 7
	Dynamic Range.....	3 - 7
	Pulse Width.....	3 - 8
	TX Power.....	3 - 8
Reduction	Interference Reduction.....	3 - 9
	Noise Reduction.....	3 - 9
Display Item Selection	Step (Sonar).....	3 - 10
	Step (Bottom Scan).....	3 - 11
	Off-Center Position.....	3 - 11
	Scale Display.....	3 - 12
	Compass Display.....	3 - 12
Others	Target Lock.....	3 - 13
	Operation mode.....	3 - 15
	Depth Unit.....	3 - 15
	Temperature Unit.....	3 - 15
	SpeedUnit.....	3 - 15
	Hoist Auto Up.....	3 - 16
	Train Correct.....	3 - 16
	Color.....	3 - 17
	Filter.....	3 - 17
CHAPTER 4	INSTALLATION.....	4 - 1
	Installation Position.....	4 - 2
	Dimensions.....	4 - 3
	Trunk Pipe Installation	
	1.Maintenance Space.....	4 - 4
	2.Installation Conditions.....	4 - 5
	Hull Unit Assembly	
	1. Joint Pipe Length.....	4 - 6
	2. Joint Pipe Adjustment.....	4 - 6
	3. Mounting Joint Pipe into Soundome.....	4 - 7
	4. Attaching Soundome to Hoist.....	4 - 8
	5. Hull unit and Trunk Pipe Attachment.....	4 - 9
	Adjustment of Hoist Stroke.....	4 - 10
	Manual Raise/Lower of Soundome.....	4 - 11
	Mounting Method of Display Unit.....	4 - 12
	Connections.....	4 - 13
	Wiring among Units.....	4 - 13
	Electrical Connections - Terminals.....	4 - 14
CHAPTER 5	OPTION.....	5 - 1
	Option.....	5 - 2
	Remote Controller.....	5 - 3
CHAPTER 6	APPENDIX.....	6 - 1
	Daily Maintenance.....	6 - 2
	Disposal.....	6 - 3
	Specifications.....	6 - 4
	Memo of Operation Mode.....	6 - 5

COMPONENTS

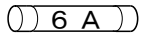
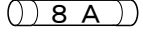
COMPONENTS

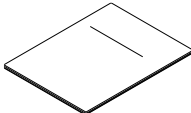
CODE		** VM110	** VM030		
PART	DISPLAY UNIT 	BRACKET 	POWER SUPPLY CABLE  2 m	KNOB BOLT 	TAPPING SCREW 
P./No	—	3 5 3 3 8 C	3 1 5 2 4 D	KG-B3	M 6 × 2 0
QTY	1	1	1	2	4

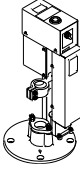
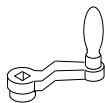
CODE	** VM121				
PART	FUSE  	DISPLAY CABINET COVER 	OPERATION MANUAL 		
P./No	—	2035-COV	S1400-OPM-E		
QTY	3 EACH	1	1		

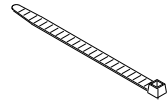

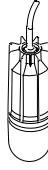
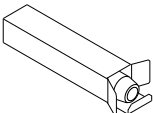
CODE	** VN010				
PART	HULL UNIT 	CRANK HANDLE 	GREASE 	ANP BASE 	BAND 
P./No	—	OB-63	—	ANP-1	AB-100-1000
QTY	1	1	100 g × 1	2	2

CODE					
PART	SOUNDOME 	SILICONE ADHESIVE 			
P./No	—	—			
QTY	1	50 g × 1			

<Continued on next page>

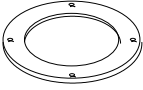
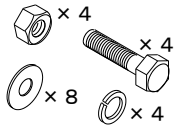
COMPONENTS

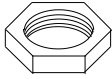
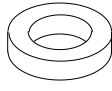
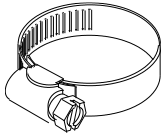
	** VN120	** VN110			
PART	GASKET 	BOLT SET 			
P./No	3 5 6 1 2 D	M20 x 80 Assy			
QTY	1	1			

CODE		** VN140			
PART	JOINT PIPE 	LOCK NUT 	DAMPER 2 	FASTENING BAND 	PIPE CAP 
P./No	3 5 6 0 8 C	3 5 6 0 9 D	3 5 6 1 1 D	S D - 2 0 5 0	3 5 6 2 4 D
QTY	1	1	1	1	1

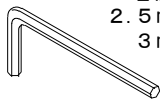
CODE	** VN140			
PART	CAP BOLT 	HEX. ROD WRENCH  2 mm 2.5 mm 3 mm		
P./No	M 4 x 6	—		
QTY	4	1 EACH		

NOTE: The code number is shown on the packages.
 ** indicates the lot management number.

SONAR SYSTEM SUMMARY

This chapter provides some basic information of the PPI (Plan Position Indicator) searchlight sonar.

SONAR MODE.....	1 - 2
TILT ANGLE.....	1 - 4
TILT ANGLE AND DISPLAY	1 - 5
BOTTOM SCAN MODE.....	1 - 6
ECHO SOUNDER MODE.....	1 - 7
SAMPLE DISPLAY OF SONAR MODE.....	1 - 8
SAMPLE DISPLAY OF BOTTOM SCAN MODE.....	1 - 8
SAMPLE DISPLAY OF ECHO SOUNDER MODE.....	1 - 9

SONAR SYSTEM SUMMARY

SONAR MODE

A sonar system uses the transmitter-receiver as well as an echo sounder. An echo sounder is only able to search in one direction, down. However a sonar has a movable transducer and therefore can freely search the entire around a ship, not just the area directly beneath the ship.

When the sonar is not operated, the transducer is retracted. While operating, the transducer is protruded from the hull bottom.

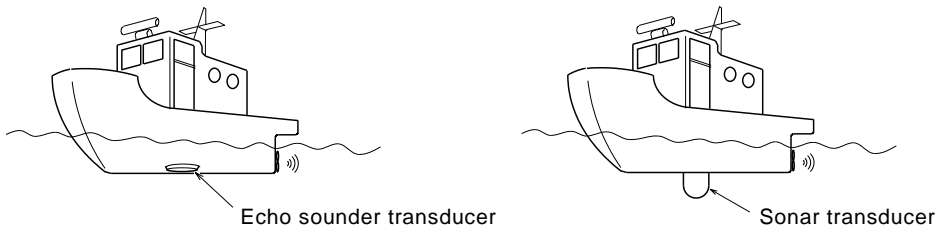

An ultrasonic pulse is emitted from the transducer protruded from the hull bottom. The sonar principle detected by the transducer is the same with the echo sounder. However, like a searchlight, the sonar transducer sends and detects ultra-sound beams one after another while giving relative bearing at some speed in proper ranges. The transducer scans or trains with the step angle set at MENU.

The seabed and fish school will send a reflected echo of sound back to the ship. In a PPI sonar, this reflection with relative bearing and range information is presented like a radar screen.

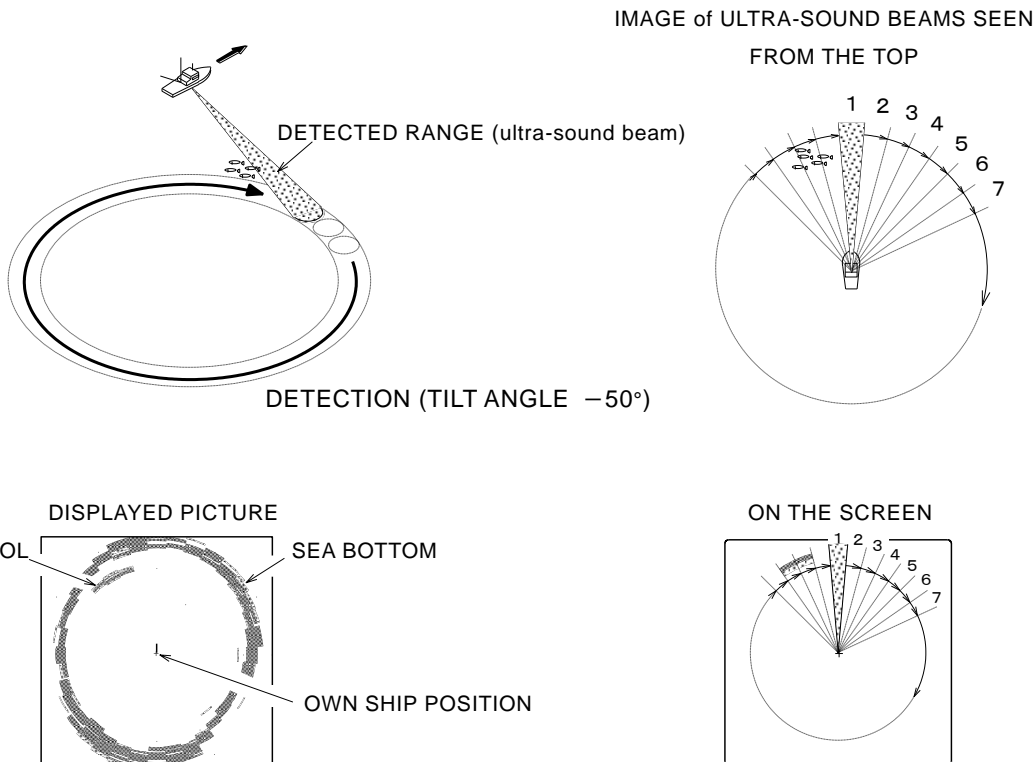

SONAR SYSTEM SUMMARY

An echo sounder is only able to search in one direction within some beam angle, beneath the ship. A sonar, however, can freely search the broad range, since the transducer's angle can be varied not only the horizontal direction but also the vertical direction.

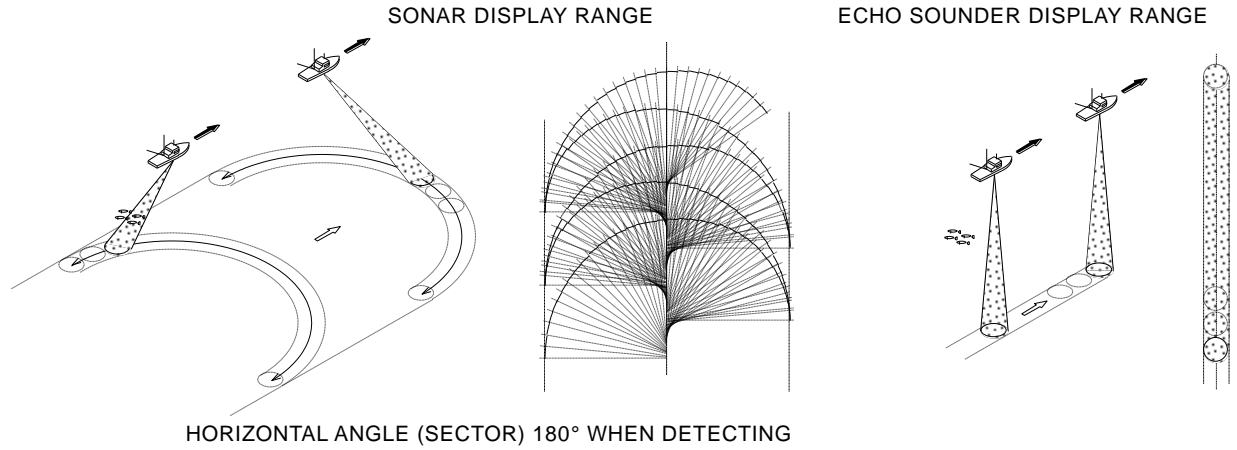

By changing the horizontal angle (Sector), the various ranges from the narrow to the full circle are available

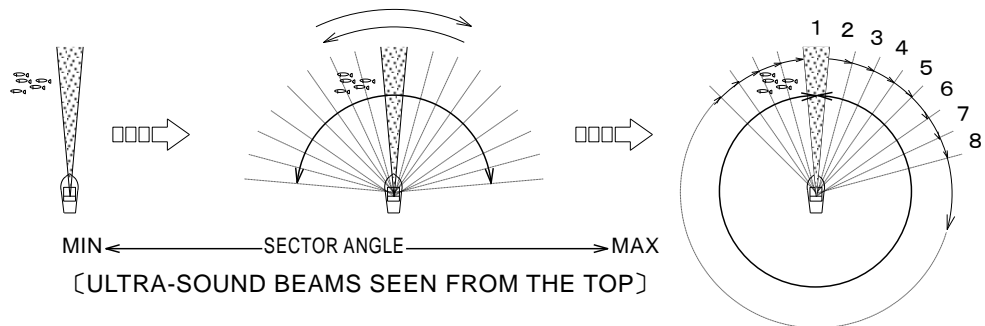

By changing the transducer's directional angle (Tilt), the ultra-sound beam angle can be varied from right beneath the ship to the horizontal direction.

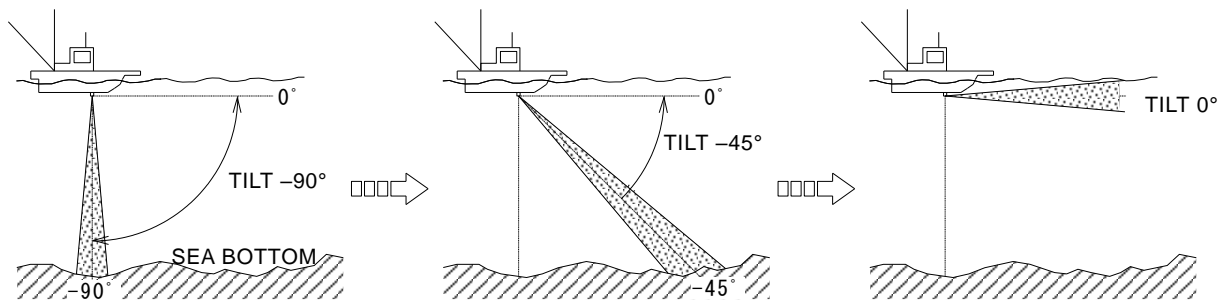

SONAR SYSTEM SUMMARY

TILT ANGLE

The tilt angle shows the direction to which the sound wave is emitted. The tilt angle can be set in step of 1° from 0° to $+5^\circ$ (upward) to 0° to 90° (downward).

Find out the suitable tilt angle for a given depth and detection range.

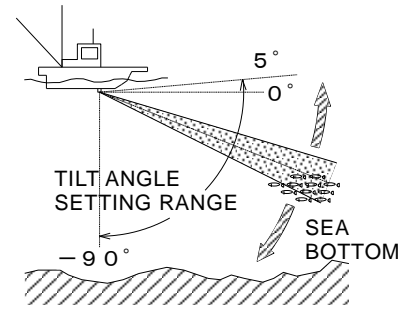

The tilt angle is of importance when working with sonar. Refer to the illustration below. Find out the suitable tilt angle and beam coverage. When the ship approaches B with the same tilt angle, the reflection is getting smaller and weaker gradually and nothing appears at B position. Without changing the tilt angle, the fish school is out of beam coverage at B position so that no reflection appears on the screen. Set an appropriate tilt angle so that the reflection of fish school always appears on the screen.

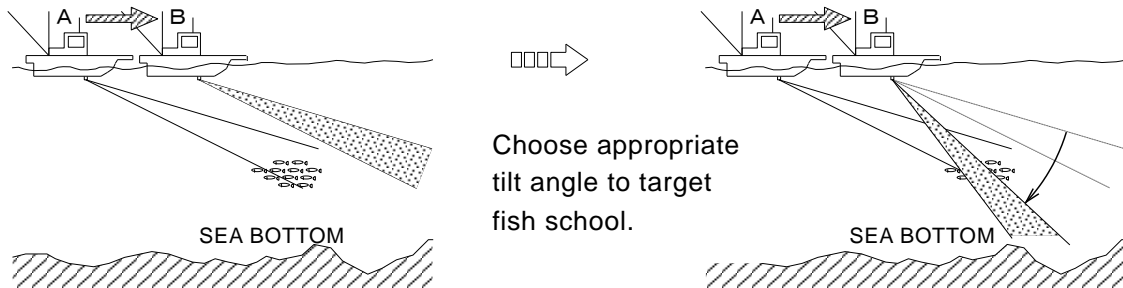

The narrow tilt angle is selected for surface detection, however, if 0° is selected, sometimes the reflection of the sea surface appears on the screen as the noise and interferes with observation of wanted echoes.

Adjust an appropriate tilt angle to lessen the affect of sea surface reflection.

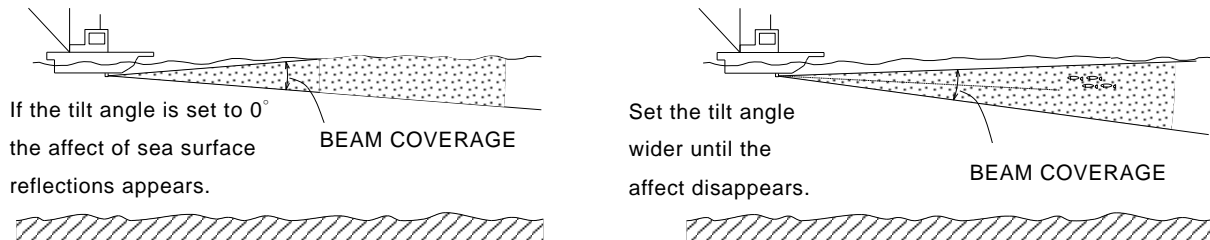

The Tilt angle is also set in the Bottom Scan mode and the Echo Sounder mode.

TILT ANGLE AND DISPLAY

In the shallow water the bottom reflection is prominent, so it is important to be able to distinguish fish echoes from the bottom echo. Therefore the setting of the tilt angle is important to find out the suitable tilt angle.

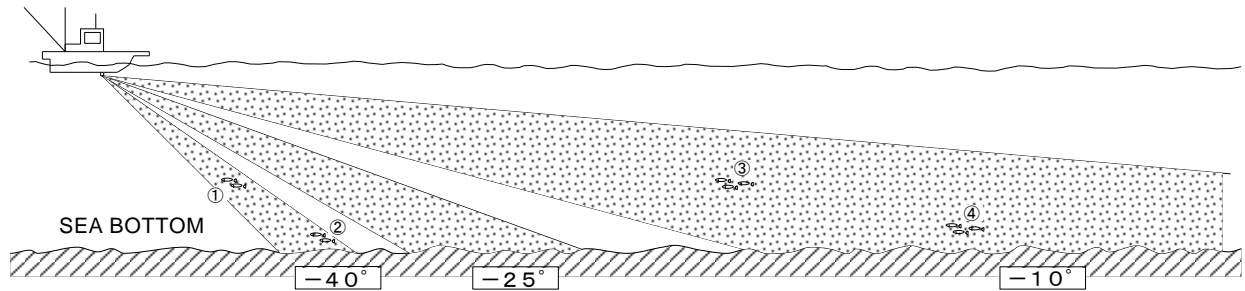

The below shows how fish schools are displayed on the screen when each different tilt angle set. The below drawings are shown under Off-Center position.

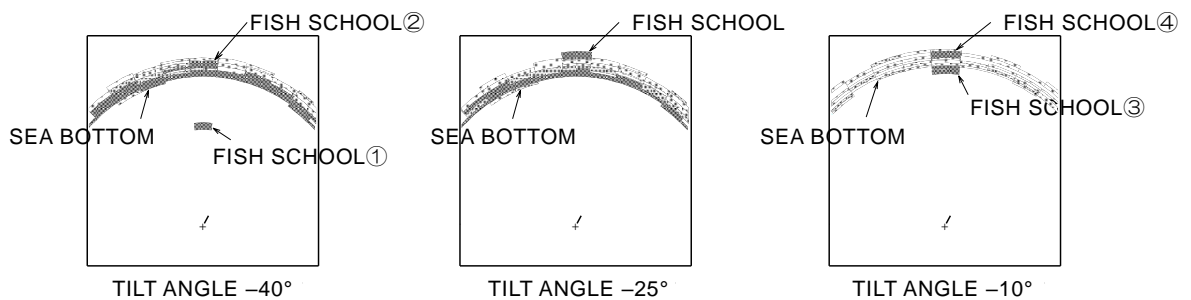

- TILT ANGLE 40° : Fish school is just above the bottom echo so that it is hard to discriminate fish echo from the bottom, since the distances from fish school and from bottom are the same.
- TILT ANGLE 25° : Fish school is clearly seen. Fish school is displayed behind the bottom echo, since fish school is in the area of weak reflection of bottom echo.
- TILT ANGLE 10° : Bottom echo is weak so that fish school is easily seen. Due to the density of fish school the strong reflection of fish school is easily displayed on the screen. Fish school ③ is actually in the middle layer, however it is displayed likely to be near the bottom echo on the screen.

NOTE !

The explanation mentioned above is extremely general explanation, and it is not a thing satisfying all conditions, which is different depending on the situation of the sea and a state of the bottom of the sea, setting of sensitivity and so on.

SONAR SYSTEM SUMMARY

BOTTOM SCAN MODE

When this mode is selected, the transmitter/receiver does not rotate like a sonar, but sweeps from side to side like a pendulum when the sound wave is emitted. The reflected echo from the sea bottom is displayed on the screen sequentially.

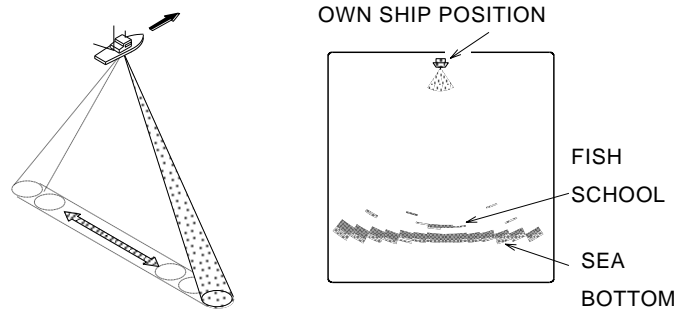

When the bottom scan mode is selected, it sweeps from side to side in the step set with STEP on MENU - DISP ITEM SEL. Changing the sector angle makes it possible to detect the wider or narrower range as desired.

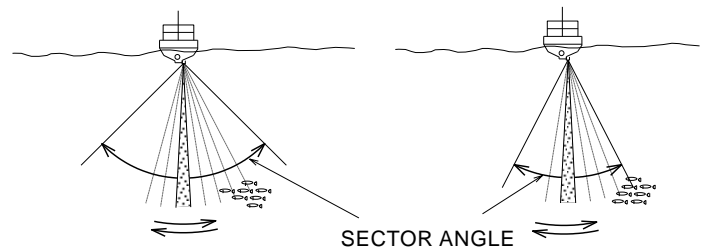

The center direction of the sounding beam can be changed with the tilt angle. Choose the setting of the tilt angle which places the sector center in the middle of the detection range.

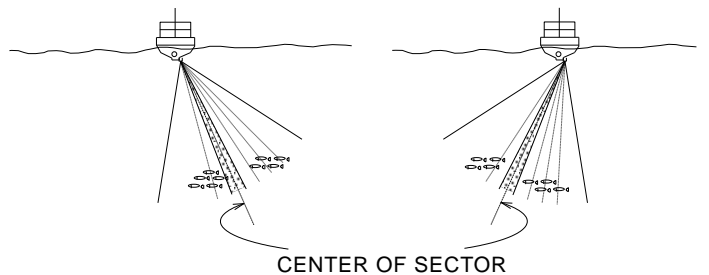

In the bottom scan mode the detectable direction is provided not only rightward or leftward, but also in the direction of 360° by setting the direction of the transducer.

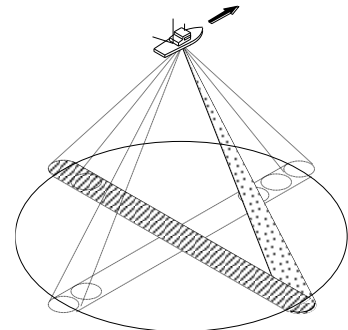

ECHO SOUNDER MODE

The transmitter/receiver faces the sea bottom, and emits the ultra-sound beam. The reflected echo from the sea bottom is displayed on the screen. The image is displayed like a usual echo sounder.

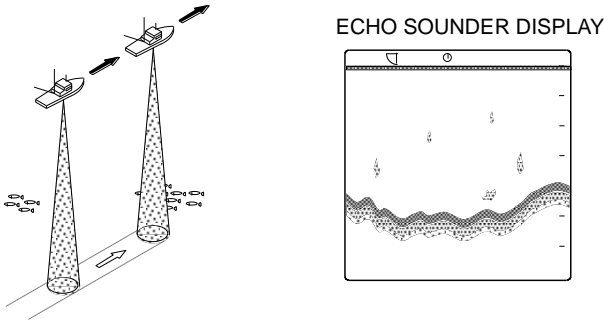

DETECTS DIRECTLY UNDER THE SHIP

The tilt angle and the direction can be changed.

CHANGES THE TILT ANGLE

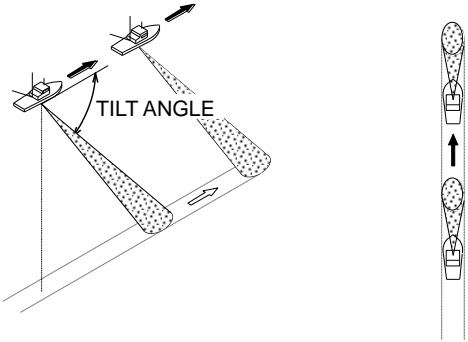

The detecting direction can be set by the Bearing keys.

CHANGES THE TILT ANGLE AND DIRECTION

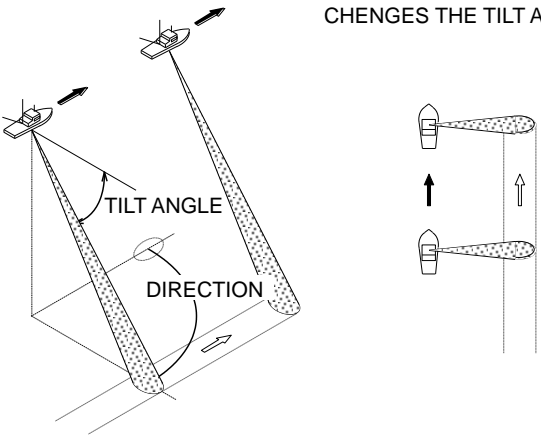

SONAR SYSTEM SUMMARY

SAMPLE DISPLAY OF SONAR MODE

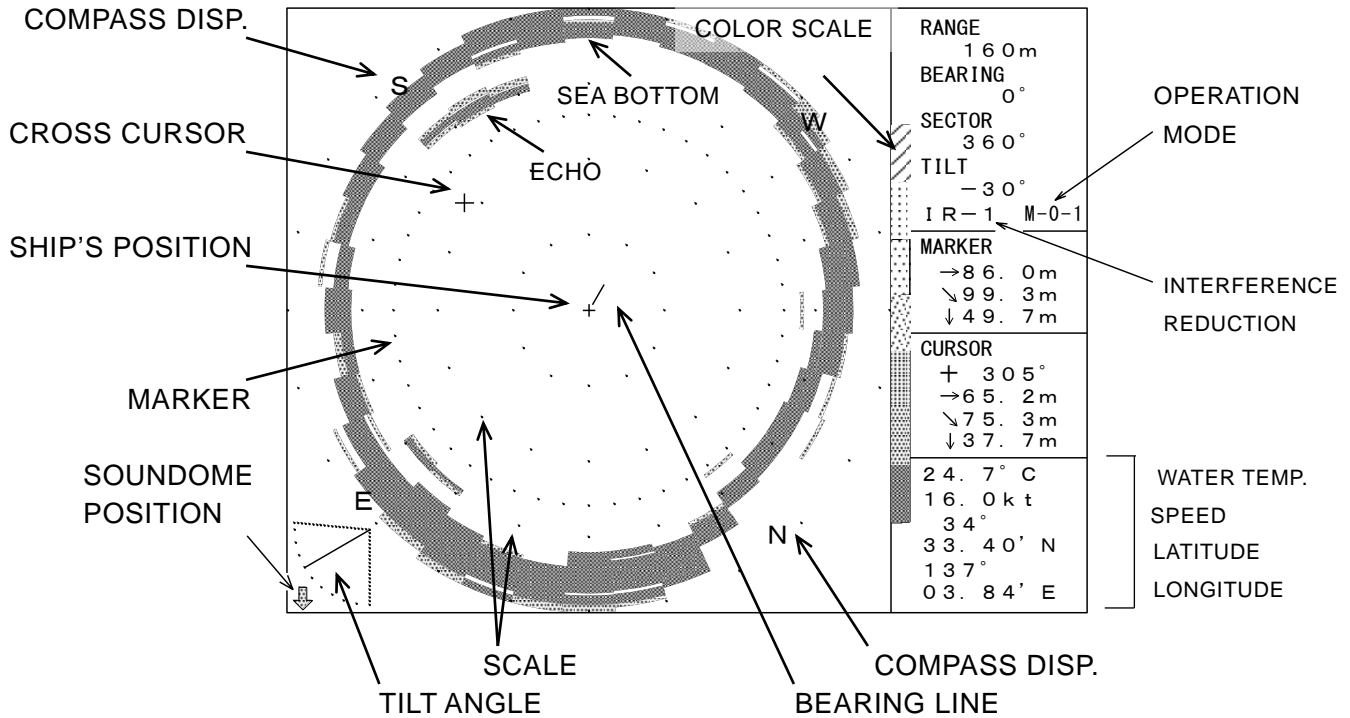

SAMPLE DISPLAY OF BOTTOM SCAN MODE

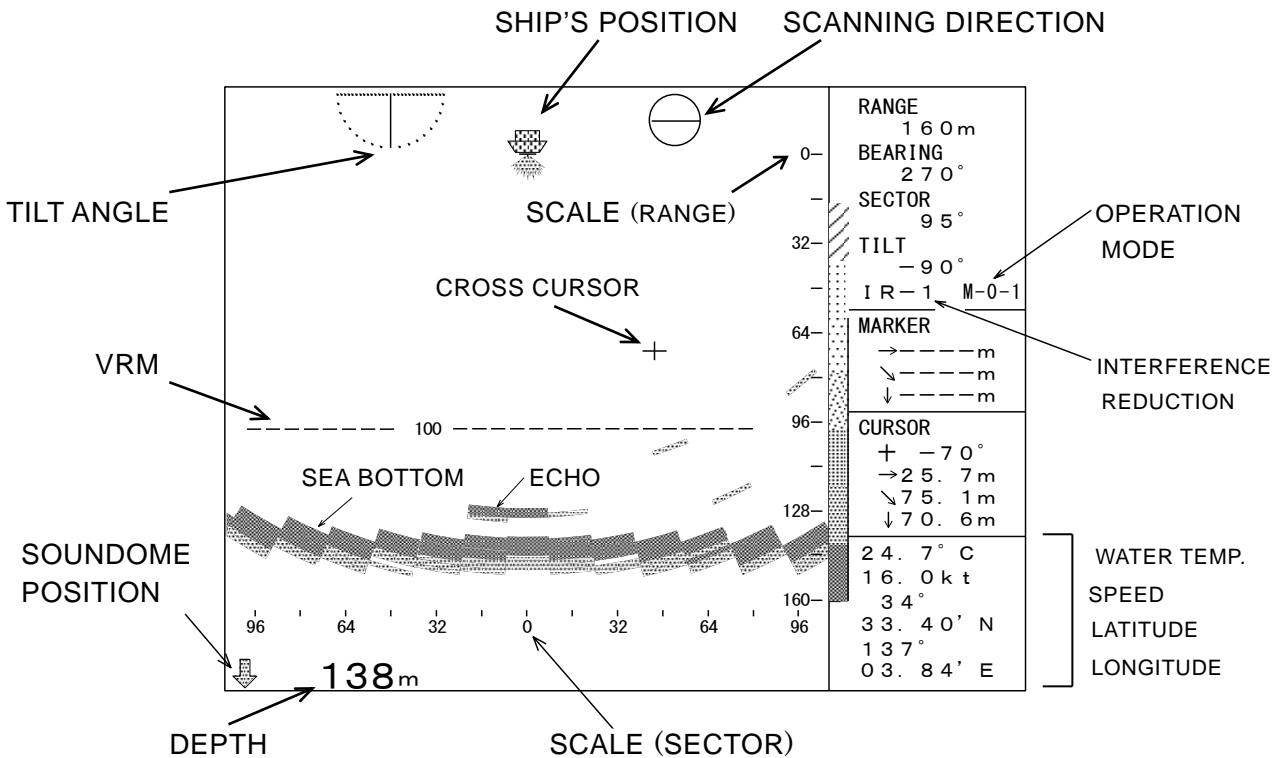

- ※ "IR" will not be displayed when INTER FERENCE RED. function "OFF" is selected.
- ※ "M-" will not be displayed if OPERATION MODE is not used.
- ※ To present WATER TEMP./SPEED/LAT/LON/COMPASS DISP. info will require S-1400 II is connected to an external equipment.

SAMPLE DISPLAY OF ECHO SOUNDER MODE

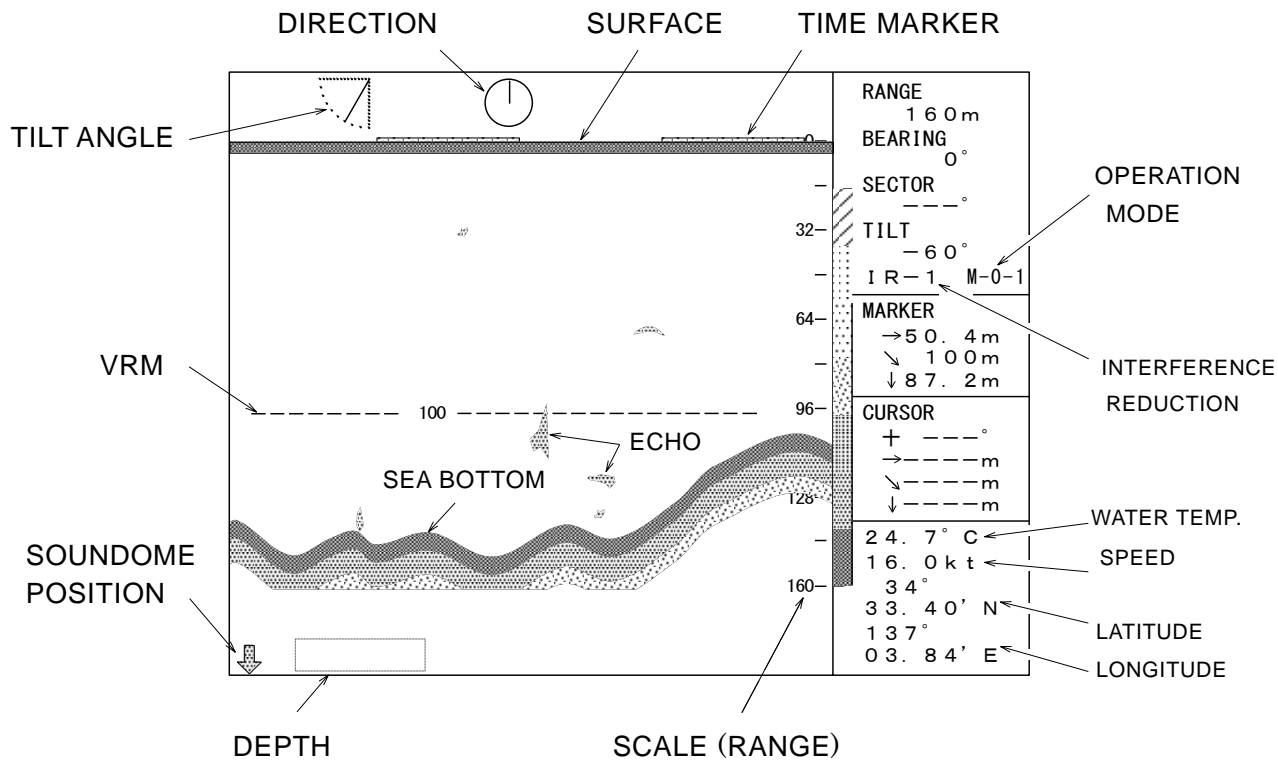

- ※ The depth is displayed when the tilt angle is -90° .
- ※ "IR" will not be displayed when INTER FERENCE RED. function "OFF" is selected.
- ※ "M-" will not be displayed if OPERATION MODE is not used.
- ※ To present WATER TEMP./SPEED/LAT/LON/COMPASS DISP. info will require S-1400 II is connected to an external equipment.

Chapter 2

SONAR OPERATION

This chapter provides you the description of operation dials and keys for the S-1400 II Sonar.

OPERATION PANEL	2 - 2
OPERATION KEYS	
Power On/Off Key.....	2 - 3
Sensor Lamp.....	2 - 3
Hoist Keys.....	2 - 3
Sonar Mode key.....	2 - 4
Off Center Mode Key.....	2 - 4
Bottom Scan / Echo Sounder Mode Key.....	2 - 4
Bearing Keys.....	2 - 5
Tilt Keys.....	2 - 6
Sector Keys.....	2 - 8
Range Keys.....	2 - 9
Operation Mode Keys.....	2 - 10
Cursor Keys.....	2 - 11
Target Lock Key.....	2 - 13
Threshold Key.....	2 - 13
Menu Key.....	2 - 14
Enter key.....	2 - 14
OPERATION DIALS	
Brightness Dial.....	2 - 15
Gain Dial.....	2 - 15
Far Gain Dial.....	2 - 15

OPERATION PANEL

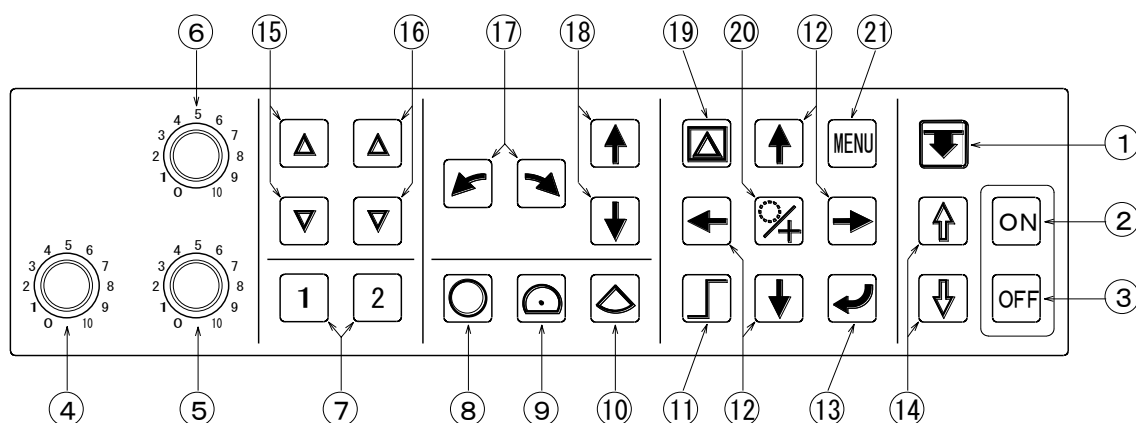

No.	NAME	ACTION
1	SENSOR LAMP	The Sensor Lamp lights while the Soundome is being raised and lowered.
2	POWER ON KEY	Turns on the power.
3	POWER OFF KEY	To turn off the power, press this key for a while. This key doesn't work by one-push.
4	BRIGHTNESS DIAL	Adjusts the screen brightness.
5	GAIN DIAL	Adjusts the receiver sensitivity.
6	FAR GAIN DIAL	Adjusts the receiver sensitivity for the long ranges and STC function.
7	OPERATION MODE KEYS	Calls up the user-defined setting or changes the settings.
8	SONAR MODE KEY	Sonar Mode.
9	OFF CENTER MODE KEY	Off-Center Mode.
10	BOTTOM SCAN / ECHO SOUNDER MODE KEY	Bottom Scan Mode or Echo Sounder Mode.
11	THRESHOLD KEY	Reduces the unnecessary weak echoes accordingly.
12	CURSOR SHIFT KEYS	Moves the cursor or selects to display Marker or Cursor. Use these keys to change the settings.
13	ENTER KEY	Press this key to set the function setting.
14	HOIST KEYS	Uploads/downloads the Soundome.
15	SECTOR KEYS	Adjusts the sector angle.
16	RANGE KEYS	Selects a desired range scale.
17	BEARING KEYS	Moves the cursor center right or left.
18	TILT KEYS	Adjusts tilt angle.
19	TARGET LOCK KEY	Turns on or off the target lock mode.
20	CURSOR SELECTION KEY	Selects Ring Marker or Cross Marker.
21	MENU KEY	Displays the function set menu.

KEY OPERATION

After pressing a key, a beep sounds when a correct key operation is done. Three short beeps sound when a wrong key is pressed.

OPERATION KEYS

POWER ON/OFF KEY

To turn on the power, press [ON] key.

When power is applied, the Soundome lowers automatically and the following will occur.

- The sensor lamp is lighted on.
- The sensor lamp mark appears on the down left corner of the screen.
- The sign “WAITING” appears on the middle of the screen while the Soundome is being lowered and then starts to operate.

To turn off the power, press [OFF] key for a while. This key does not work by one-push.

When power is turned off, the Soundome raises automatically and the following will occur.

- The sensor lamp stops lighting when the Soundome is completely uploaded.

Do not cut the power until the sensor lamp is lighted off.

SENSOR LAMP

The sensor lamp lights while the Soundome is being lowered or raised and also Completely lowered. It goes off when the Soundome is fully retracted.

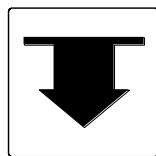

SENSOR

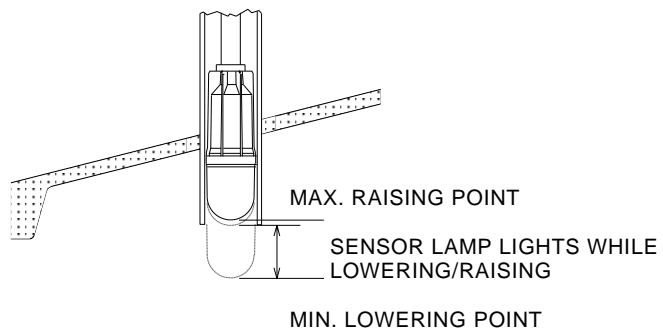

HOIST KEYS

With the ship at the fishing ground, the hoist key raise or lower the Soundome.

- Pressing the Hoist [↑] key raises the Soundome and the arrow mark on the screen points upward. The sensor lamp stops lighting when the Soundome is completely uploaded.
- Pressing the Hoist [↓] key lowers the Soundome and the arrow mark on the screen points downward. The sensor lamp lights.
- Slow down the ship's speed before pressing the Hoist [↓] key in case of lowering the Soundome again after the automatic soundome retraction.

SONAR MODE KEY

Displays the Sonar Mode.

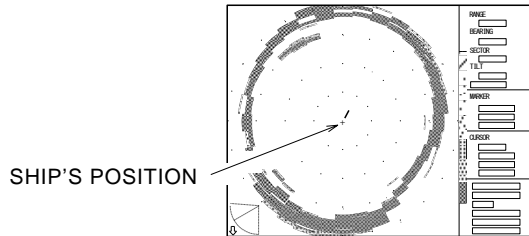

- Tilt angle is adjusted by the Tilt keys. **CF** page 2-6
- Sector angle is adjusted by the Sector keys. **CF** page 2-8
- The scanning direction is adjusted by the Bearing keys. **CF** page 2-5

OFF CENTER MODE KEY

Displays the Off-Center Mode.

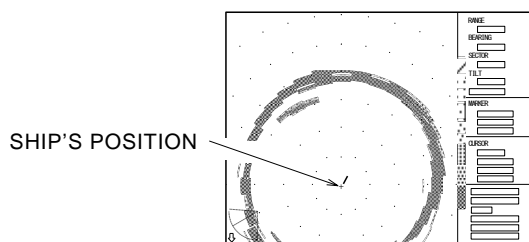

- It allows showing more information ahead (rightward) by moving the ship's position downward (leftward) on the screen. **CF** page 3-11

BOTTOM SCAN / ECHO SOUNDER MODE KEY

Displays the Bottom Scan Mode or the Echo Sounder Mode.

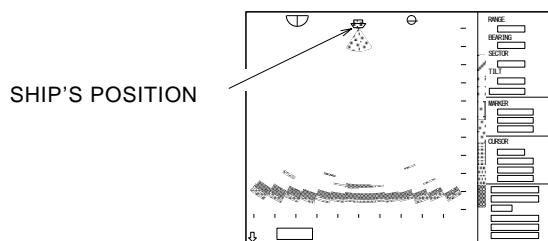

BOTTOM SCAN MODE

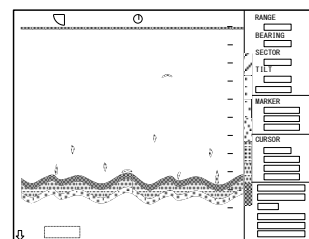

ECHO SOUNDER MODE

- The scanning direction is adjusted by the Bearing keys. **CF** page 2-5
- Tilt angle is adjusted by the Tilt keys. **CF** page 2-6/2-7
- Sector angle is adjusted by the Sector keys in Bottom Scan Mode. **CF** page 2-8

OPERATION KEYS

BEARING KEYS

Use these keys to define the center of current scanning sector in the Sonar Mode. The bearing angle of the display is shifted with every 5° steps.

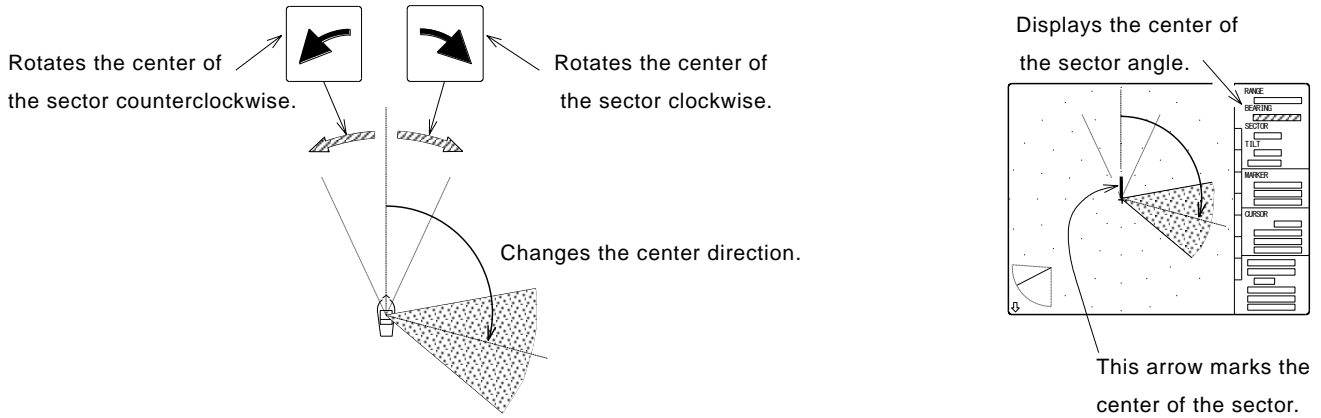

Use these keys to define the center of current scanning sector in the Bottom Scan Mode. The bearing angle of the display is shifted with every 5° steps.

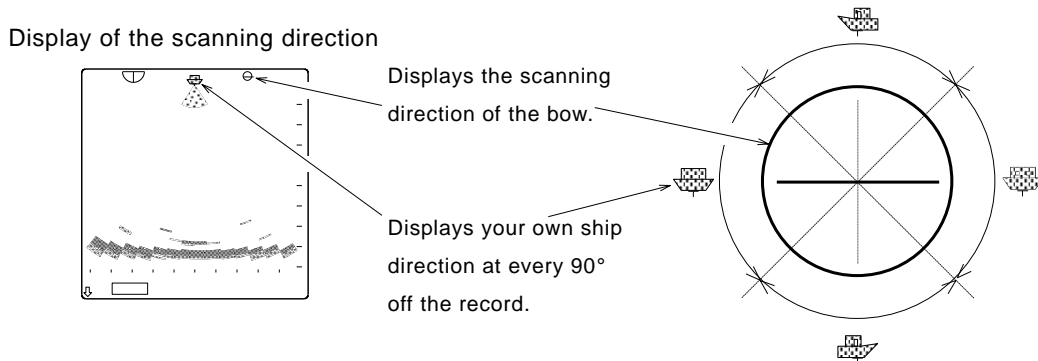
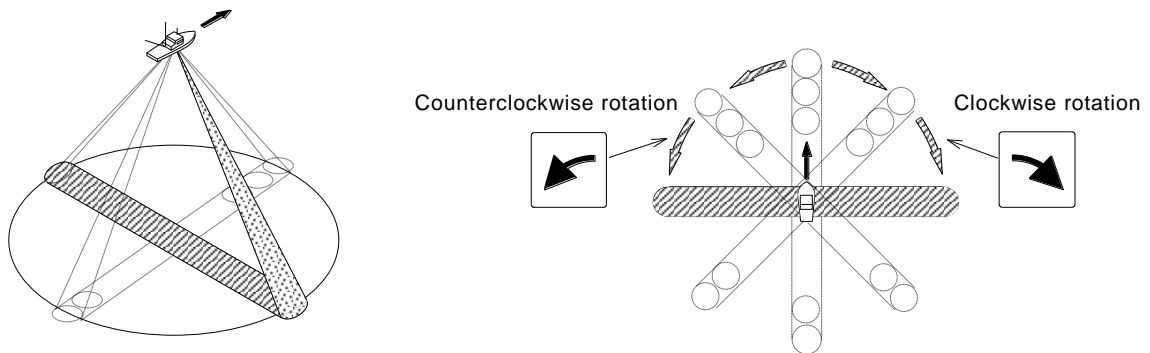

Use these keys to define the scanning direction in the Echo Sounder Mode. The bearing angle of the display is shifted with every 5° steps.

TILT KEYS

Use these keys to control the tilt angle in the Sonar Mode.

- The tilt angle can be set in increments of 1° from 0° to 5° (upward) to 0° to 90° (downward).

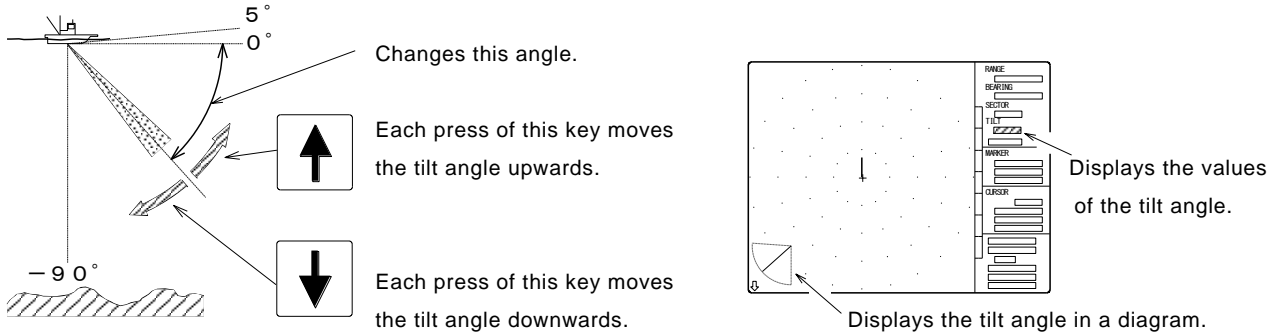

Use these keys to control the scanning center direction of the detection range in the Bottom Scan Mode.

- Variable range in increments of 3° step: -3° ~ -90° and -3° on another side
- Variable range in increments of 5° step: -5° ~ -90° and -5° on another side

(Refer to the page 3-11 for steps)

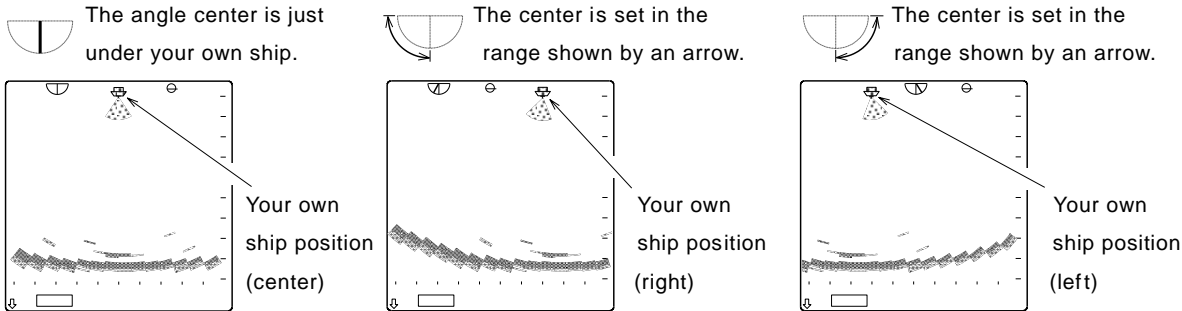
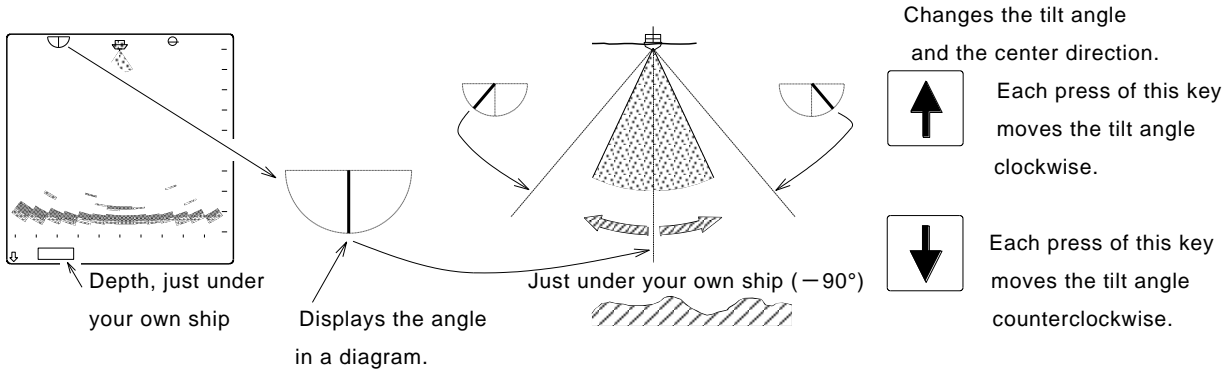

OPERATION KEYS

Use these keys to control the tilt angle in the Echo Sounder Mode.

- The tilt angle can be set in increments of 1° from 0° to 5° (upward) to 0° to 90° (downward).

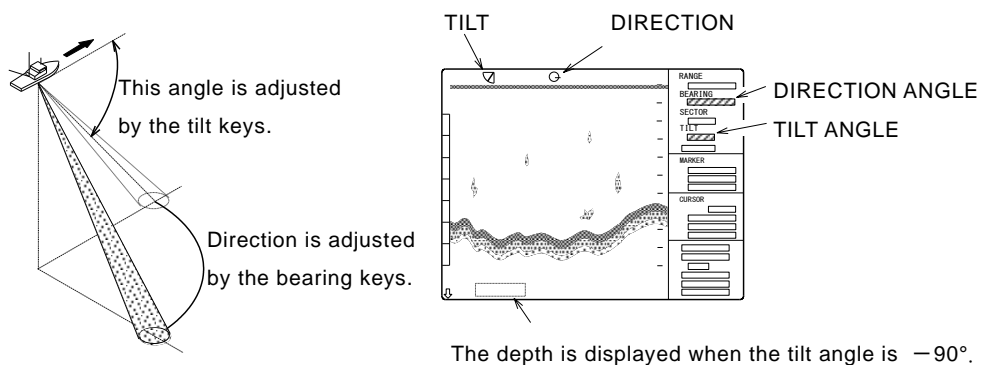

- Use VRM to read the depth if the tilt angle is not -90° . (Refer to the page 2-11 for VRM).

SECTOR KEYS

Changes the sector angle (horizontal angle) in the Sonar Mode.

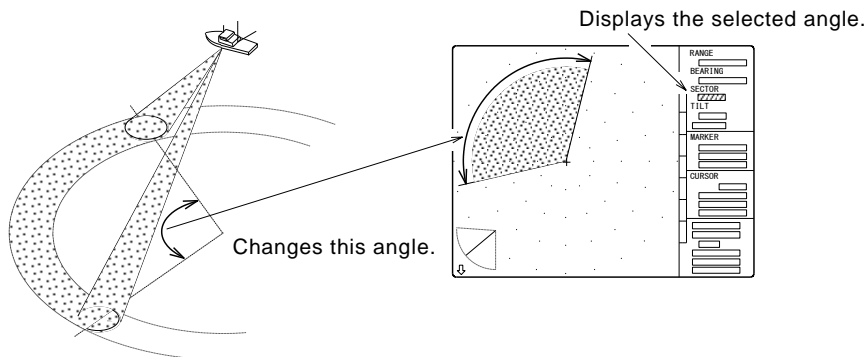

- Each press of the Sector [Δ] key widens the sector angle.
- Each press of the Sector [∇] key narrows the sector angle.

8 selectable sector angles in the Sonar Mode

5° STEP	5°	25°	45°	85°	125°	165°	205°	360°
10° STEP	10°	30°	50°	90°	130°	170°	210°	360°

(Refer to the page 3-10 for steps)

Changes the sector angle (vertical angle) in the Bottom Scan Mode.

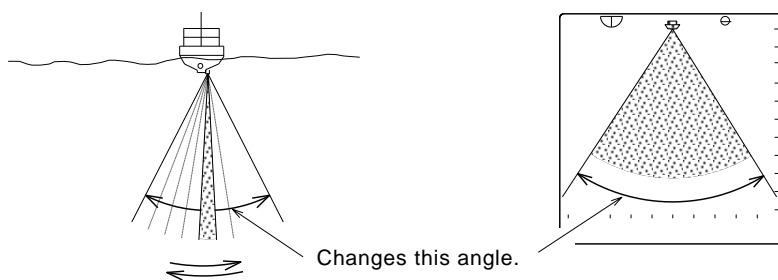

- Each press of the Sector [Δ] key widens the sector angle.
- Each press of the Sector [∇] key narrows the sector angle.

8 selectable sector angles in the Bottom Scan Mode

3° STEP	3°	27°	45°	63°	93°	117°	147°	177°
5° STEP	5°	25°	45°	65°	95°	115°	145°	175°

(Refer to the page 3-11 for steps)

OPERATION KEYS

RANGE KEYS

Changes the basic range (the basic depth)

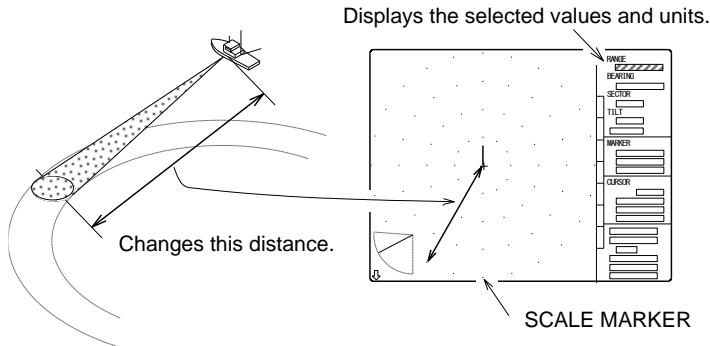

- 20 selectable ranges are available.
- Each press of the Range [Δ] key makes the range value smaller.
- Each press of the Range [∇] key makes the range value larger.
- The setting for the depth unit is accessed by using "FUNCTION SETTINGS." **CF** page 3-15
- Scale marker can be turned on or off by using "FUNCTION SETTINGS." **CF** page 3-12

BASIC RANGE

RANGE	m			br/fm		
	SONAR	OFF CENTER	BOTTOM SCAN / ECHO SOUNDER	SONAR	OFF CENTER	BOTTOM SCAN / ECHO SOUNDER
0	10	15	10	10	15	10
1	20	30	20	20	30	20
2	30	45	30	30	45	30
3	40	60	40	40	60	40
4	50	75	50	50	75	50
5	60	90	60	60	90	60
6	70	105	70	70	105	70
7	80	120	80	80	120	80
8	90	135	90	90	135	90
9	100	150	100	100	150	100
10	120	180	120	110	165	110
11	140	210	140	120	180	120
12	160	240	160	130	195	130
13	180	270	180	140	210	140
14	200	300	200	150	225	150
15	220	330	220	160	240	160
16	240	360	240	170	255	170
17	260	390	260	180	270	180
18	280	420	280	190	285	190
19	300	450	300	200	300	200

OPERATION MODE KEYS

Use these keys to select one of 2 kinds of operation mode you have created. (You may be able to create 4 kinds of operation mode by FUNCTION SETTINGS. **CF** page 3-15) By pressing one of these keys, the desired operation mode can be set immediately.

To memorize the setting in the Operation Mode key, the following procedure is required.

- Create your own setting of operation mode.
- Exit Menu.
- Hold the Operation Mode [1] or [2] key for 3 seconds until you hear a beep. The operation mode that you have created is now memorized in the Operation Mode key. Note that it may not be memorized when the key is released before you hear a beep.
- By pressing the Operation Mode [1] or [2] key, you hear a beep and the desired operation mode appears on the screen instantly. Note that you hear 3 beeps and nothing changes when pressing the Operation Mode [1] or [2] key memorized nothing.
- You may adjust the setting while one of the operation modes works, however pressing one of the Operation Mode keys again returns to the previous operation mode.
- It is possible to memorize the present setting in the Operation Mode keys by holding the key for 3 seconds.
- The Operation Mode key number appears on the screen.

RANGE	160m
BEARING	0°
SECTOR	360°
TILT	-30°
IR-1	M-0-1
MARKER	
→	86.0m
↘	99.3m
↓	49.7m
CURSOR	
+	305°
→	65.2m
↘	75.3m
↓	37.7m
	24.7°C
	16.0kt
	34°
	33.40' N
	137°
	03.84' E

indicates the function setting number you selected.

indicates the Operation Mode key number you selected.

OPERATION KEYS

CURSOR KEYS

By using these keys, the horizontal range, depth and bearing to the target can be measured.

- Use [Cursor Selection] key to select a cursor and [↑][↓][←][→] keys move the cursor in any direction on the screen.



:activates either Ring Marker or Cross Cursor in the Sonar Mode.

:activates either VRM or Cross Cursor in the Bottom Scan Mode.

:activates either VRM in the Echo Sounder Mode.



:expands the Ring Marker, shifts the Cross Cursor upward, or shifts VRM to the shallow.

:moves the highlighted item upward in the Menu.



:contracts the Ring Marker, shifts the Cross Cursor downward, or shifts VRM to the deeper area.

:moves the highlighted item downward in the Menu.



:shifts the Cross Cursor left.

:selects the content of the item in the Menu.



:shifts the Cross Cursor right.

:selects the content of the item in the Menu.

The Ring Marker or the Cross Cursor neither appears nor operates on the screen when turning on the power at the very first time.

- The Marker appears by pressing either [↑] or [↓] key, and then select the Ring Marker or the Cross Cursor by [Cursor Selection] key.
- The inactive function is displayed in red and stored even if the power is turned off.
- Press [↑] and [↓] keys at the same time to turn the Marker off.
- Pressing [↑] or [↓] key again returns the Marker to the previous position.

When the Ring Marker is selected (the Cross Cursor is in red or not displayed,)

• **SONAR MODE**

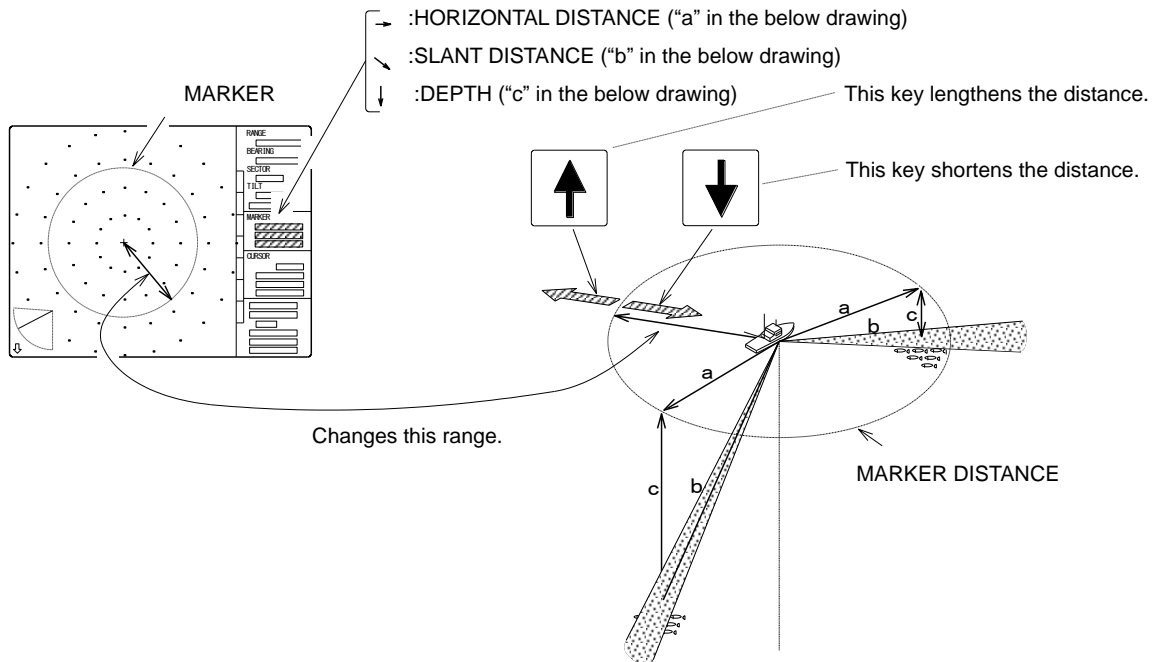

• **BOTTOM SCAN MODE**

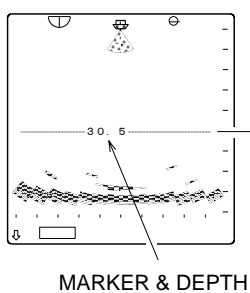

• **ECHO SOUNDER MODE**

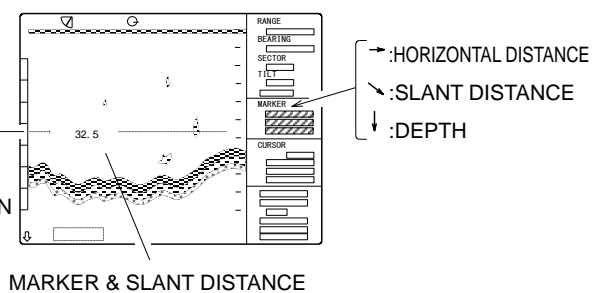

In Bottom Scan Mode Marker data is not presented and VRM appears on the screen.

In Echo Sounder Mode Marker data is presented and Slant distance appears on the screen.

When the Cross Cursor is selected (the Ring Marker is in red or not displayed,)

- Set the Cross Cursor on a target by using the Cursor Shift [↑] [↓] [←] [→] keys, and the depth and horizontal/slant distance to the target are displayed in the Cursor box.

SONAR MODE

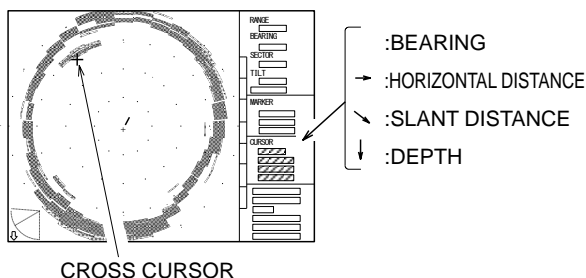

BOTTOM SCAN MODE

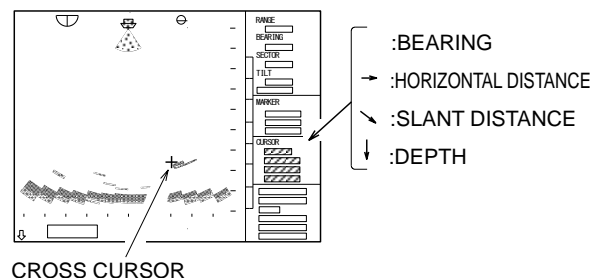

OPERATION KEYS

TARGET LOCK KEY

When pressing the Target Lock key in the Sonar Mode, the direction of sweep of the sonar beam is reversed. (When MENU / TARGET LOCK / MODE 0 is selected.)

When pressing the Target Lock key in the Sonar Mode, the sonar beam tracks the echo automatically. (When MENU / TARGET LOCK / MODE 1 or MODE 2 is selected.)

The red-letter "TARGET LOCK" is displayed at the position of both "BEARING" and "SECTOR" on the screen right.

- Please refer to page 3-13 for more details of the Target Lock operation.

THRESHOLD KEY

The weak echoes disappear by pressing this key accordingly.

- Only strong wanted targets appear on the screen by pressing this key to erase unwanted returns such as plankton or noise.
- Each press of Threshold key clears the weakest color sample.

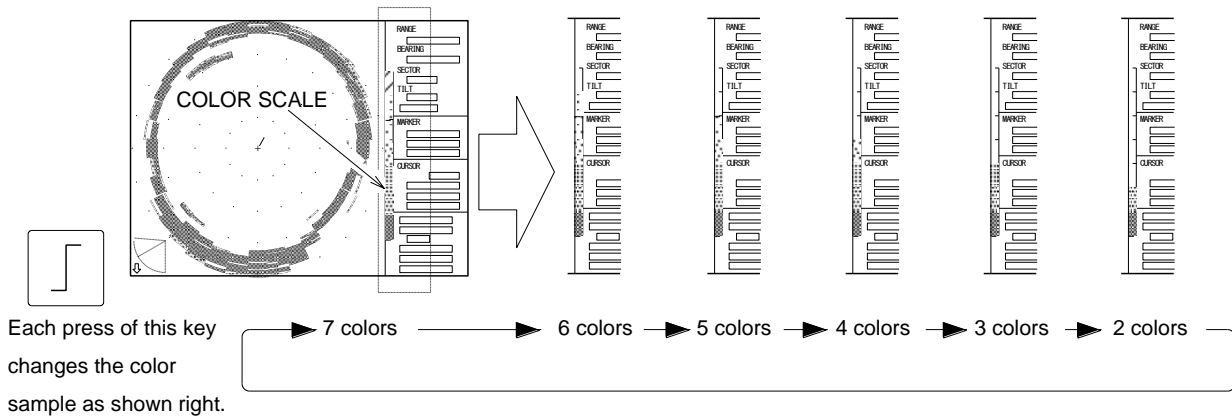

MENU KEY

Use this key to set the basic functions.

- Pressing this key displays MAIN MENU on the right of the screen.
- Refer to Chapter 3 “FUNCTION SETTINGS” for more details.
- By pressing this key again, MAIN MENU disappears.
- Pressing this key returns to MAIN MENU when the setup menu is displayed.
- Use the Enter key to set the function item you changed.

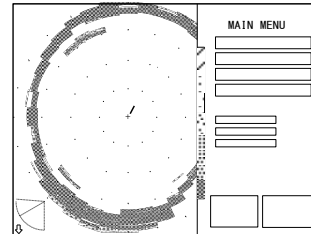

ENTER KEY

After you change the settings in the setup menu, press this key.

- Note that the content of the settings is not changed when you exit MAIN MENU by pressing the Menu key even if you set the function items.

OPERATION DIALS

BRIGHTNESS DIAL

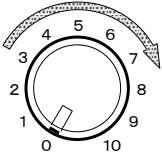

Turn this dial clockwise to increase the screen brightness and “10” is the brightest.

GAIN DIAL

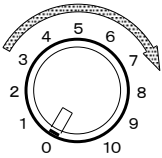

Adjusts the sensitivity of the received signal and turn this dial Clockwise to increase the gain.

- Gain controls can be adjusted by “GAIN UP” function in FUNCTION SETTINGS. **CF** page 3-6

FAR GAIN DIAL

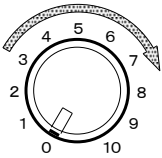

TVG CURVE in FUNCTION SETTINGS 10LOG ~ 40LOG

As the echoes returning from the bottom and from fish targets get weaker as the depth increases, it is advantageous to have a Time-varied-gain function that automatically compensates for propagation loss of sound. **CF** page 3-7

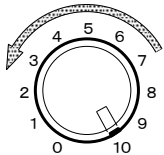

STC function in TVG CURVE in FUNCTION SETTINGS

This STC function enables you to reduce noise interference resulting from bubbles, dirt, etc. near the surface of the water. As the dial is turned toward “0”, then the STC effect will become progressively from the surface to the distance stronger.

- Selecting STC function releases the gain adjustment automatically so that the sensitivity of the receiver becomes weaker in the distance.
- Gain controls can be adjusted by the Gain Dials and “GAIN UP” function in FUNCTION SETTINGS.

CF page 3-6

FUNCTION SETTINGS

This chapter provides you the main functions of the S-1400 II Sonar and describes the primary controls. It also suggests settings to use for initial start up.

INITIAL SETTINGS

Factory Settings.....	3 - 2
Return to Factory Settings.....	3 - 3
User Settings.....	3 - 3

MENU

Function Set Menu.....	3 - 4
------------------------	-------

FUNCTION SETTINGS

SETTING FUNCTIONS.....	3 - 5
Gain Up.....	3 - 6
TVG Curve.....	3 - 7
Dynamic Range.....	3 - 7
Pulse	
Width.....	3 - 8
TX Power.....	3 - 8

REDUCTION

Interference Reduction.....	3 - 9
Noise Reduction.....	3 - 9

DISPLAY ITEM SELECTION

Step (Sonar).....	3 - 10
Step (Bottom Scan).....	3 - 11
Off-Center Position.....	3 - 11
Scale Display.....	3 - 12
Compass Display.....	3 - 12

OTHERS

Target Lock.....	3 - 13
Operation Mode.....	3 - 15
Depth Unit.....	3 - 15
Temperature Unit.....	3 - 15
Speed Unit.....	3 - 15
Hoist Auto Up.....	3 - 16
Train Correct.....	3 - 16
Color.....	3 - 17
Filter.....	3 - 17

INITIAL SETTINGS

FACTORY SETTINGS

The S-1400 II is shipped from the factory with the functions under the settings listed below.

- Before using it, please enter the functions to the desired setup.

FUNCTIONS	FACTORY SETTINGS (in the item □)	
FUNCTION SET GAIN UP TVG CURVE DYNAMIC RANGE PULSE WIDTH TX POWER	<input type="checkbox"/> OFF · +10dB · +20dB · +30dB · +40dB <input type="checkbox"/> OFF · 10LOG · 20LOG · <input checked="" type="checkbox"/> 30LOG · 40LOG 1dB · 2dB · <input checked="" type="checkbox"/> 3dB NARROW · <input checked="" type="checkbox"/> NORMAL · WIDE · 0.3ms LOW · <input checked="" type="checkbox"/> HIGH	<input checked="" type="checkbox"/> CF page 3-5
REDUCTION INTERFERENCE RED. NOISE REDUCTION	<input checked="" type="checkbox"/> OFF · 1 · 2 · 3 <input checked="" type="checkbox"/> OFF · ON	<input checked="" type="checkbox"/> CF page 3-9
DISP ITEM SEL. STEP (SONAR) STEP (BOTTOM SCAN) OFF-CENTER POS. SCALE DOTS COMPASS DISP.	5° · <input checked="" type="checkbox"/> 10° 3° · <input checked="" type="checkbox"/> 5° <input checked="" type="checkbox"/> FORE · BACK · RIGHT · LEFT <input checked="" type="checkbox"/> OFF · <input checked="" type="checkbox"/> ON <input checked="" type="checkbox"/> OFF · ON	<input checked="" type="checkbox"/> CF page 3-10
OTHERS TARGET LOCK OPERATION MODE DEPTH UNIT TEMP. UNIT SPEED UNIT HOIST AUTO UP (SPEED UNIT: kt) (SPEED UNIT: km/h) TRAIN CORRECT COLOR FILTER	<input checked="" type="checkbox"/> MODE 0 · MODE 1 · MODE 2 <input checked="" type="checkbox"/> 0 · 1 <input checked="" type="checkbox"/> m · br · fm · ft <input checked="" type="checkbox"/> °C · °F <input checked="" type="checkbox"/> kt · km/h <input checked="" type="checkbox"/> OFF · 1kt ~ 15kt <input checked="" type="checkbox"/> OFF · 1km/h ~ 27km/h <input checked="" type="checkbox"/> 0° ~ 355° <input checked="" type="checkbox"/> A-1 · A-2 · B-1 · B-2 · C-1 · C-2 · D-1 · D-2 <input checked="" type="checkbox"/> OFF · 1 · 2	<input checked="" type="checkbox"/> CF page 3-13
OPERATION MODE 1 · 2 USER SETTINGS	NO SETTINGS NO SETTINGS	

RETURN TO FACTORY SETTINGS

First press the Power [OFF] key, then press [ON] key while pressing both the Bearing keys [←][→] at the same time.

Keep pressing the Bearing keys [←][→] until the beep sound stops.

- Activating this operation will erase all settings excluding "Train Correct" at FUNCTION SETTINGS, and restore the basic settings from the factory.

USER SETTINGS

Being separated from the Factory Setting function, Settings may be entered by the user and memorized. This function is called "User Settings". By entering "User Settings" the S-1400 II to suit individual needs can be done. This not only simplifies operation of the S-1400 II, but also adds considerably to its reliability.

- All user-implemented data in the S-1400 II can be erased by making a reset of the unit and thus return to "User settings". Please ensure the "User settings" are memorized on the first operation.

1. MEMORIZE USER SETTINGS

- First ensure the functions are at the desired settings.
- After disconnecting the power supply once by pressing the Power [OFF] key, then turn the power supply back on, while pressing both the Operation Mode [1] and the Power [ON] keys at the same time. Keep pressing [1] and [ON] keys until the beep sound stops.
- After completing this operation all functions and their units will be memorized as set by the user.

2. RETURN TO USER SETTINGS

- In case, for some reason, the S-1400 II becomes inoperable, the unit can be reset by disconnecting the power supply and then turn the power supply back on, while pressing the Operation Mode [2] and the Power [ON] keys at the same time. Keep pressing [2] key until the beep sound stops.
- This operation can return to "User Settings."

3. CHANGING USER SETTINGS

- To change the functions in User Settings first activate "Return to Factory Settings" and then memorize "User Settings" again as described in the previous item 1.

NOTE !

Releasing the keys before the beep sounds stops may not complete the above-mentioned settings. Performing "Return to Factory Settings" will return all settings to Factory Settings and erase all User Settings.

MENU

FUNCTION SET MENU

Basic functions may be briefly described in the following.

- Before first using the S-1400 II , customizing the functions to suit individual needs.
- The following function items can be customized in the function set menu.

MAIN MENU

FUNCTION SET

:GAIN UP
:TVG CURVE
:DYNAMIC RANGE
:PULSE WIDTH
:TX POWER

REDUCTION

:INTERF RED (INTERFERENCE REDUCTION)
:NOISE REDUCTION

DISP ITEM SEL (DISPLAY ITEM SELECTION)

:STEP (SONAR)
:STEP (BOTTOM SCAN)
:OFF-CENTER POS. (OFF-CENTER POSITION)
:SCALE DOTS
:COMPASS DISP. (COMPASS DISPLAY)

OTHERS

:TARGET LOCK
:OPERATION MODE
:DEPTH UNIT
:TEMP. UNIT
:SPEED UNIT
:HOIST AUTO UP
:TRAIN CORRECT
:COLOR
:FILTER

REMOTE CONTROLLER

FUNCTION SETTINGS

Press the Menu key to display the menu below.

- Use the Cursor Shift key [↑] or [↓] to highlight the item you wish to change.
- By pressing the Cursor Shift key [←] or [→] the following is displayed.

MAIN MENU

FUNCTION SET

REDUCTION

DISP ITEM SEL.

OTHERS

REMOTE CONTROLLER

S-1400 II 220kHz

****/**/**

Ver *.***

SELF CHECK

HOI ST OK

TRAI N OK

Use the Cursor Shift key [↑] or [↓] to highlight the item you wish to change.

The setup display is accessed by pressing the Cursor Shift key [←] or [→].

-----Frequency and Version No. of EPROM

-----SELF CHECK FUNCTION
The test result NG in red is displayed in case of some troubles.

SETTING FUNCTIONS

FUNCTION SET

GAIN UP	OFF
TVG CURVE	30 LOG
DYNAMIC RANGE	3 d B
PULSE WIDTH	NORMAL
TX POWER	HIGH

GAIN GAIN00 FAR GAIN00

Use the Cursor Shift key [↑] or [↓] to highlight the item you wish to change.
Press [←] or [→] key to select the desired setting.

-----Graph for Gain Characteristics displays the changed gains such as TVG curve, Gain Up, Gain dial and Far Gain dial, etc.

FUNCTION SETTINGS

1. GAIN UP

This function makes it possible to display a clearer picture of the full range and control the sensitivity at various depths.

- Each press of [←] or [→] key changes the setting, "OFF, +10dB, +20dB, +30dB, +40dB."
- Select the desired value, and then press the Enter key.

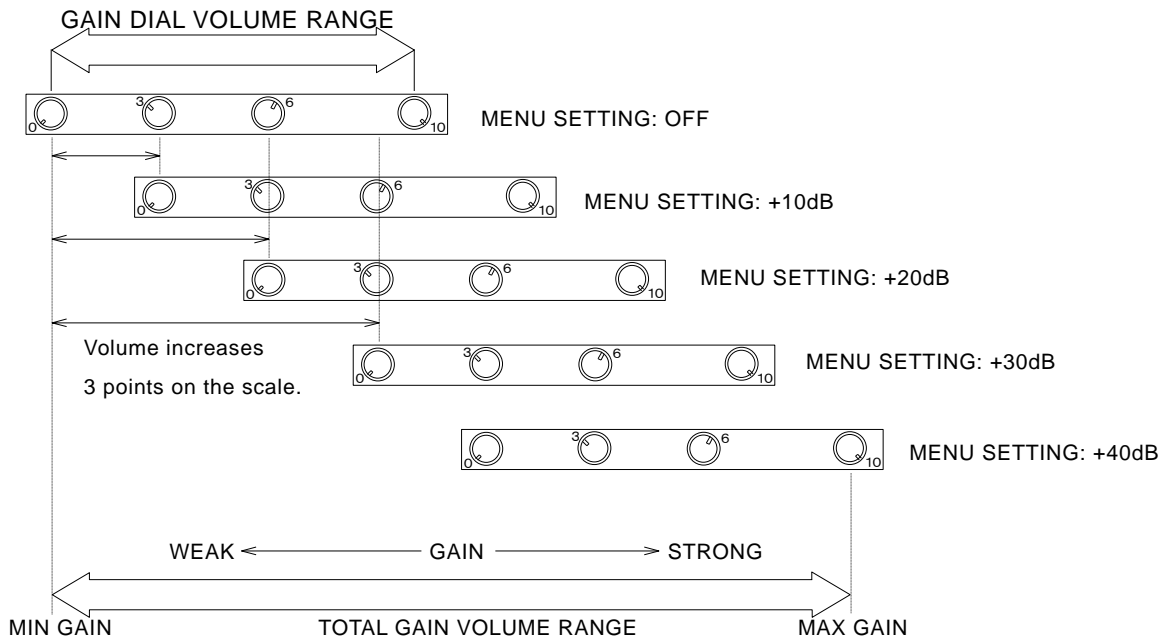

- When the menu gain adjust setting is changed from "OFF" to "+10dB," the gain dial volume increases 3 points on the scale.
- When the menu gain adjust setting is "OFF" and the front panel dial is on "3," it has the same result as when the menu gain adjust setting is on "+10dB" and the gain dial is on "0."

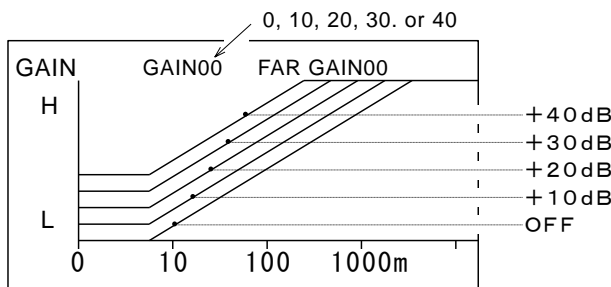

- Selected GAIN UP, Gain Characteristics Diagram shifted accordingly shows left under the following conditions.

Gain dial	: 0
Far Gain dial	: 0
TVG Curve	: 30LOG

2. TVG CURVE

TVG offsets the effects of propagation loss of sound as it passes through the water. Propagation loss of sound is the sum of spreading and attenuation losses. The TVG curve is adjusted to counter the loss.

- Each press of [←] or [→] key changes the setting, "OFF, 10LOG, 20LOG, 30LOG, 40LOG."
- Select the desired value, and then press the Enter key.

OFF : STC function
 10LOG : Curve ① in the below drawing.
 20LOG : Curve ② in the below drawing.
 30LOG : Curve ③ in the below drawing.
 40LOG : Curve ④ in the below drawing.

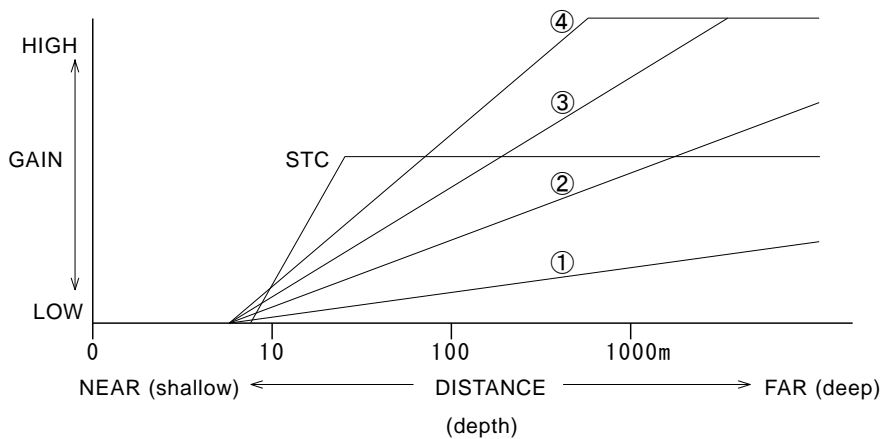

- In accordance with the distance the gain increases automatically even if the gain volume is unchanged as seen in the above drawing.

3. DYNAMIC RANGE

By shifting the dynamic range, the display to reflect the received echo more precisely or the display to discriminate their density is selected.

- Each press of [←] or [→] key changes the setting, "1dB, 2dB, 3dB."
- Select the desired value, and then press the Enter key.
- The diagram shows the comparative signal threshold levels for the dynamic ranges.

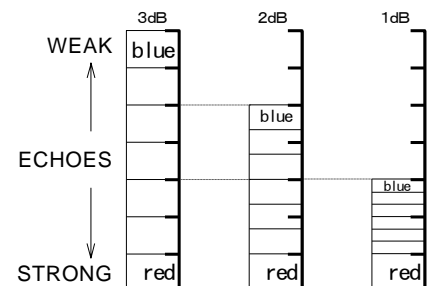

FUNCTION SETTINGS

4. PULSE WIDTH

The transmitted pulse width can be set.

- The transmitted pulse can be set to these three (narrow, normal, wide), where the optimum setting will be applied according to the range automatically.
- Or it can be set manually, if a specific pulse width (0.1 ~ 3.6 msec) is required.
- Each press of [←] or [→] key changes the setting, "NARROW, NORMAL, WIDE, 0.3ms."
- Select the desired value, and then press the Enter key.

NORMAL	: Setting NORMAL changes automatically according to the range.
NARROW	: When the searching range is short and higher resolution is required, the pulse width should be set NARROW.
WIDE	: The longer range gives less resolution.
CONSTANT	: The initial value of the pulse width is 0.3 ms. The pulse width is to be set every 0.1 ms unit from 0.1 to 3.6 ms.

- Use [↑] key to select the larger value.
- Use [↓] key to select the smaller value.

NOTE !-----

In actual practice, the shorter pulse (narrower) gives better resolution, and Less noise in shallow water or surface scanning. The longer pulse (wider) will reach deeper but give less resolutions.

5. TX POWER

The output power of the ultrasonic sound wave may be selected.

- In crowded fishing areas, this function may be used to reduce power and avoid interference to other Fishing boat's Sonars and Echo Sounders.
- Each press of [←] or [→] key change the setting, "LOW or HIGH."
- Select the desired level of the transmitting power, and then press the Enter key.

REDUCTION



- Use the Cursor Shift key [↑] or [↓] to highlight the item you wish to change.
- Press [←] or [→] key to select the desired setting.

1. INTERFERENCE REDUCTION

This function may be used to eliminate noise from other boats.

- Each press of [←] or [→] key changes the setting, "OFF, 1, 2, 3."
- Select the desired level of the reduction, and then press the Enter key.
- "OFF" indicates this function is inactive.
- As the level of the setting close to HIGH, higher level of reduction is set and the level of reducing interference appears at the right of the screen.

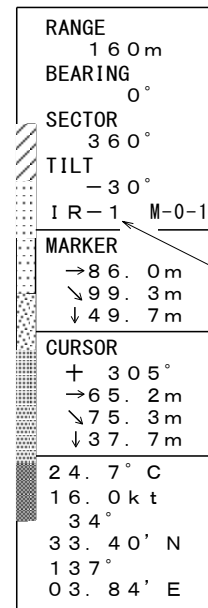

Selected level is displayed.

2. NOISE REDUCTION

This function may be used to eliminate small noise.

- Each press of [←] or [→] key changes the setting, "OFF or ON."
- Select ON or OFF, and then press the Enter key.

[OFF : Noise reduction is not functioning.
ON : Noise reduction is functioning.

FUNCTION SETTINGS

DISPLAY ITEM SELECTION

DISP ITEM SEL.	
STEP (SONAR)	10°
STEP (BOTTOM SCAN)	5°
OFF-CENTER POS.	FORE
SCALE DOTS	ON
COMPASS DISP.	OFF

- Use the Cursor Shift key [↑] or [↓] to highlight the item you wish to change.
- Press [←] or [→] key to select the desired setting.

1. STEP (SONAR)

The step angle (scanning angle) in the Sonar Mode may be selected.

- Each press of [←] or [→] key changes the setting, "5° or 10°."
- Select the desired step angle, and then press the Enter key.

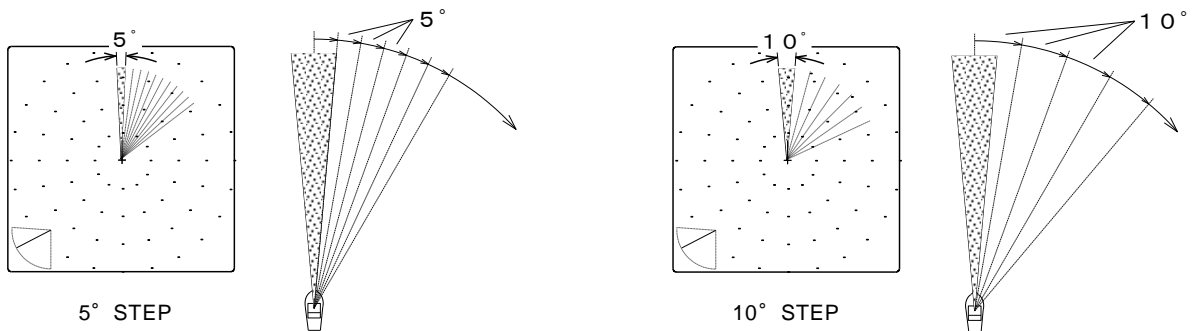

NOTE !

Narrower step: The image density is increased but the rotational speed is reduced.

Wider step: The image density is reduced but the rotational speed is increased.

2. STEP (BOTTOM SCAN)

The step angle (scanning angle) in the Bottom Scan Mode may be selected.

- Each press of [←] or [→] key changes the setting, "3° or 5°."
- Select the desired step angle, and then press the Enter key.

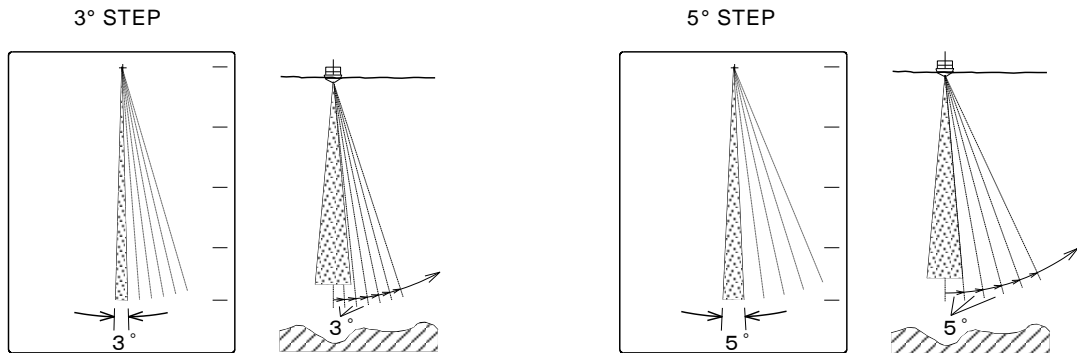

3. OFF-CENTER POSITION

The ship's position on the screen may be selected in the OFF-CENTER Mode.

- Each press of [←] or [→] key changes the setting, "FORE, BACK, RIGHT, LEFT."
- Select the desired center position, and then press the Enter key.

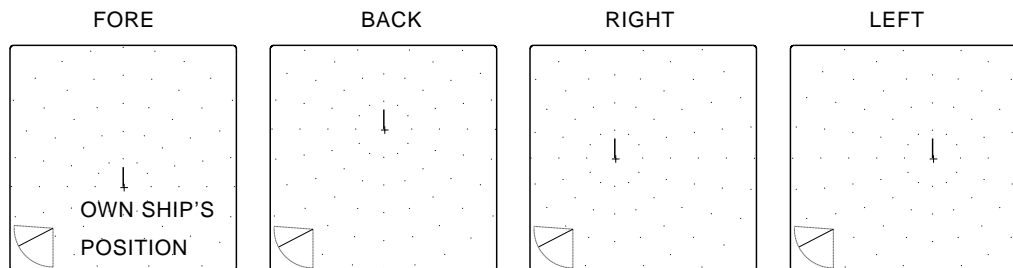

FUNCTION SETTINGS

4. SCALE DISPLAY

The scale dots display under the Sonar Mode can be turned on / off.

- Each press of [←] or [→] key changes the setting, "ON or OFF."
- Select ON or OFF, and then press the Enter key.

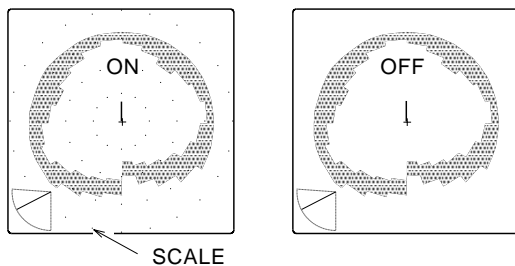

- When the scale dots display OFF is selected, no scale appears on the screen in the SONAR / OFF-CENTER Modes.
- When the scale dots display OFF is selected, scale appears on the screen in the Bottom Scan Mode.

5. COMPASS DISPLAY

The points of the compass can be shown on the screen in the Sonar Mode by connecting "NAV IN" terminal to an external navigator.

- Each press of [←] or [→] key changes the setting, "ON or OFF."
- Select ON or OFF, and then press the Enter key.

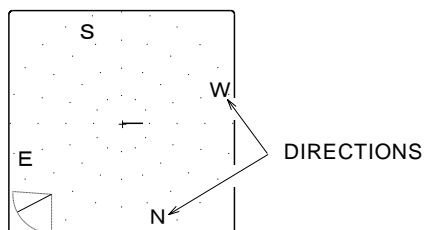

OTHERS

OTHERS	
TARGET LOCK	MODE 0
OPERATION MODE	0
DEPTH UNIT	m
TEMP. UNIT	°C
SPEED UNIT	kt
HOIST AUTO UP	OFF
TRAIN CORRECT	0°
COLOR	A-1
FILTER	OFF

- Use the Cursor Shift key [↑] or [↓] to highlight the item you wish to change.
- Press [←] or [→] key to select the desired setting.

1. TARGET LOCK

This function changes the rotary direction or tracks the target automatically.

- To select the desired Target Lock function when the Target Lock key is pressed in the Sonar mode.
- Each press of [←] or [→] key changes the setting, "MODE 0, MODE 1, MODE 2."
- Select the desired MODE, and then press the Enter key.

MODE 0

- Each press of the Target Lock key reverses the sector rotary direction.
- Not tracking the echo automatically.

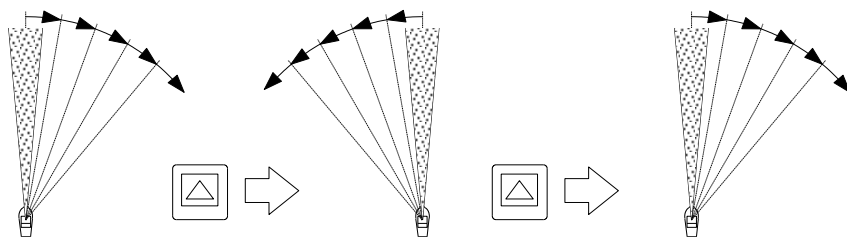

FUNCTION SETTINGS

MODE 1

- By pressing the Target Lock key, the Sonar beam will track the echo automatically left and right.
- "TARGET LOCK" will be displayed at the right of the screen.
- If the beam should have lost the echo and not picked it up again after a 60° sweep, the Target Lock function will be released.

RANGE	** * m
TARGET LOCK	
TILT	- 3 0 °
I R - 1	M - 0 - 1
MARKER	
	→ ** . * m
	↘ ** . * m
	↓ ** . * m
CURSOR	
	+ ** * °
	→ ** . * m
	↘ ** . * m
	↓ ** . * m
	** . * ° C
	** . * k t
	** * °
	** . * * ' N
	** * °
	** . * * ' E

MODE 2

- The Sonar beam will track the echo automatically up and down (one time of up and down track after three times of left and right track) in addition to the MODE 1 functions.

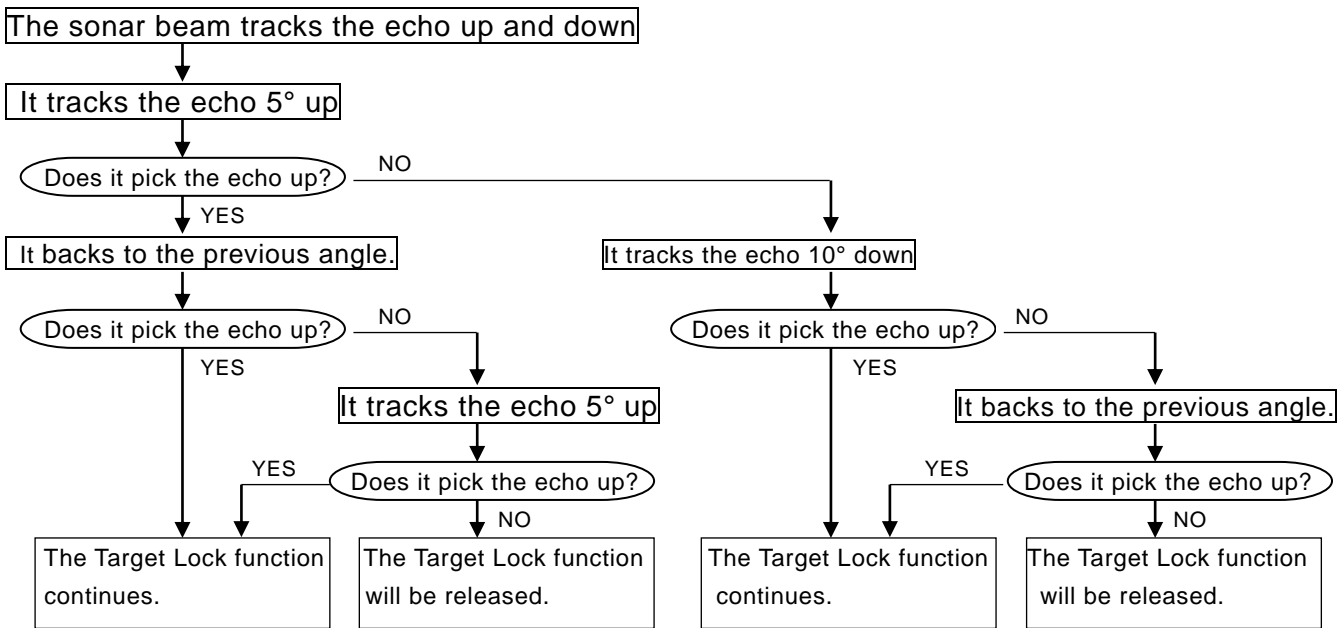

NOTE !

During the Target Lock operation, Tilt, Bearing, and Sector keys will not be operated.

And if the Range, Sector, Display Mode or Menu key is pressed, the Target Lock function will be released.

When the Target Lock function ceases, Bearing and Sector angles will return to their original positions, but Tilt angle will remain in Target Lock position.

The Target Lock function is not available in the Bottom Scan and Echo Sounder Modes.

2. OPERATION MODE

4 kinds of operation mode can be memorized by switching the function setting number “0” or “1” with the operation mode [1] and [2] keys.

- Each press of [←] or [→] key changes the setting, “0 or 1.”
- Select the desired function setting number, and then press the Enter key.

3. DEPTH UNIT

The user may select the displayed depth unit to be one of the following: meter (m), braccia (br), fathom (fm) or feet (ft).

- Each press of [←] or [→] key changes the setting, “m, br, fm, ft.”
- Select the desired depth unit, and then press the Enter key.

4. TEMPERATURE UNIT

Temperature unit can be set to °C or °F.

- To display water temperature, the water temperature data should be read in NMEA-0183 sentences.
- Each press of [←] or [→] key changes the setting, “°C or °F.”
- Select the desired temperature unit, and then press the Enter key.

5. SPEED UNIT

It can be shown in knots (kt) or kilometers/hour (km/h).

- Each press of [←] or [→] key changes the setting, “kt or km/h.”
- Select the desired speed unit, and then press the Enter key.

FUNCTION SETTINGS

6. HOIST AUTO UP

The Soundome can be retracted automatically when the ship speed is over a specified speed by connecting to an external equipment.

- Each press of [←] or [→] key changes the setting, "OFF, 10kt (18km/h)."
- Select the desired value, and then press the Enter key.
- Use the Tilt Key [↑] or [↓] to change the speed after selecting the initial value 10 kt (18 km/h). Selectable values : "1 kt ~15 kt" or "1 km/h ~ 27 km/h"
Tilt key [↑] : increases the value Tilt key [↓] : decreases the value
- Soundome position mark shows the down direction [downward arrow] on the left bottom of the screen while the Soundome is lowering. When the Hoist Auto Up function is activated, the mark changes into [upward arrow]. The Sensor Lamp goes off when the Soundome is retracted automatically.

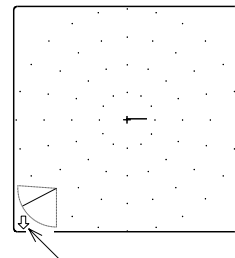

Shows the Soundome position, lowering or raising.

We recommend the ship speed below 15kt (27km/h) while retracting.

7. TRAIN CORRECT

To adjust the deviation of the bow direction (0°), the following procedure is required.

- In the Sonar mode, use [←] or [→] key to set the Bearing toward Bow direction.
- Press the Menu key, and select OTHERS.
- Highlight "TRAIN CORRECT."
- Press [←] or [→] key to display the degree that you have set in the Sonar mode.
- Press the Enter key.

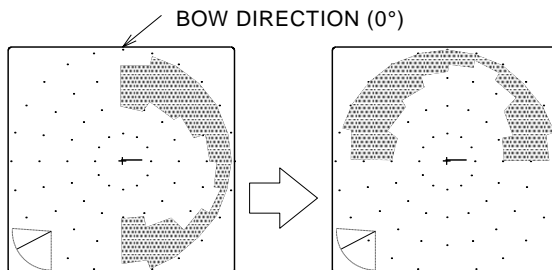

[EXAMPLE]
Set the bearing at 90°, the display turned 90° counterclockwise.

- Releasing this function, set the current bearing at 0° and follow the above procedure.

8. COLOR

The display tone (COLOR BAR) and the background color may be selected as desired from 4 optional patterns, "A-1, A-2, B-1, B-2."

And the tone range may be specified freely on C-1 and C-2 in Color Palette function. (The initial setting of the color tone for C-1 is the same as A-1 and C-2 is the same as B-1.) "D-1", "D-2" can support Color Palette.

ECHO which added filter process is set as initial setting for easy to see.

- Each press of [←] or [→] key changes the setting, "A-1, A-2, B-1, B-2, C-1,C-2,D-1,D-2"
- Select the desired tone, and then press the Enter key.

GUIDES TO THE COLOR PALETTE

C-1 and C-2 can be customized to suit individual needs and wishes.

- Use [←] or [→] key to select C-1 or C-2, and then press the Threshold key to display COLOR PALLET SET Menu.

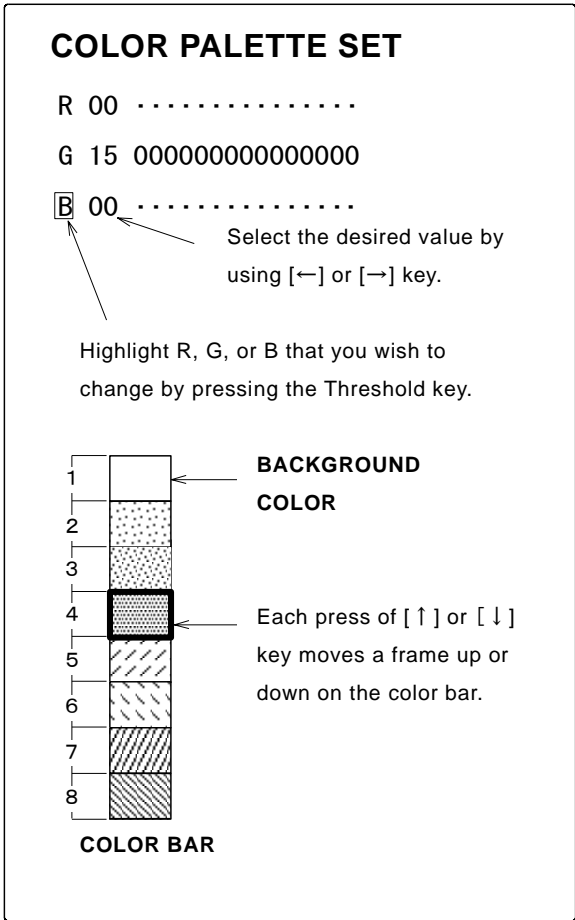

- Use [↑] or [↓] key to select the color (number from 1 to 8) that you wish to change. The levels of the three primary colors "red (R), green (G), blue (B)", scale from 0 to 15, are displayed above the color bar.
- Highlight R, G, or B that you wish to change by pressing the Threshold key, and select the level of the color (scale 0 to 15) by using [←] and [→] keys.
- The number 15 is the strongest color and its tone decreases in accordance with the smaller number.
- Press the Enter key to memorize the desired color selection into C-1 or C-2.

9. FILTER

- Filter Processing has added to ECHO DISPLAY to make echo easy to see.
- "OFF" is Standard ECHO, "2" is more strong filter use than 1

Chapter 4

INSTALLATION

This chapter explains the installation for sonar monitor and hull unit.

INSTALLATION POSITION	4 - 2
DIMENSIONS	4 - 3
TRUNK PIPE INSTALLATION	
1. Maintenance Space.....	4 - 4
2. Installation Conditions.....	4 - 5
HULL UNIT ASSEMBLY	
1. Joint Pipe Length.....	4 - 6
2. Joint Pipe Adjustment.....	4 - 6
3. Mounting Joint Pipe into Soundome.....	4 - 7
4. Attaching Soundome to Hoist.....	4 - 8
5. Hull Unit and Trunk Pipe Attachment.....	4 - 9
ADJUSTMENT OF HOIST STROKE	4 - 10
MANUAL RAISE/LOWER OF SOUNDOME	4 - 11
MOUNTING METHOD OF DISPLAY UNIT	4 - 12
CONNECTIONS	4 - 13
WIRING AMONG UNITS	4 - 13
ELECTRICAL CONNECTIONS – TERMINALS	4 - 14

Fully discussion and agreement are required with the ship owner and dockyard in deciding the location for the hull unit. Give careful considerations on mounting.

INSTALLATION POSITION

Select an area where noise, bubbles and interference from turbulences are minimal.

The point at $1/3$ to $1/2$ of the ship's length from the bow is the best.

If the hull unit can not be installed on the keel, the center of the Trunk Pipe should be within 1 meter of the keel.

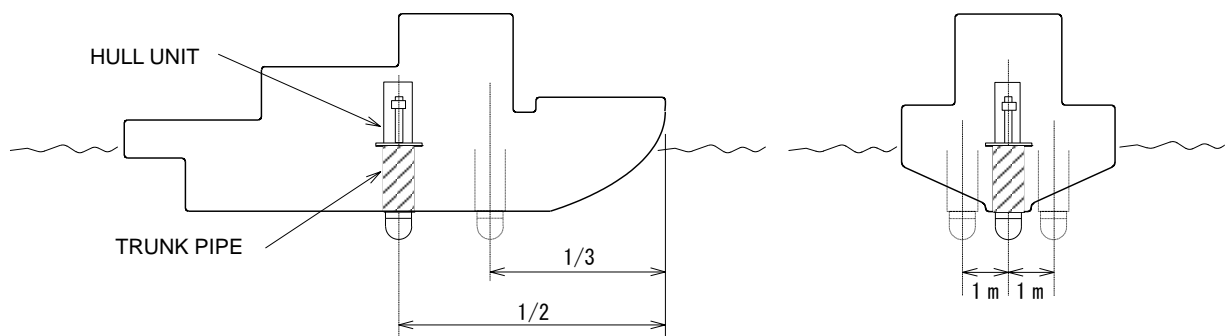

Be sure there are no obstacles to interfere the ultrasonic beam when the Soundome is lowered.

Provide sufficient clearance around the Trunk Pipe for maintenance and inspection work.

Install the unit so that the Flange comes above the draft at full load.

Make the bulkhead in consideration of safety to an emergency flood if you install the Trunk Pipe in the engine room.

The Bow mark (Δ) on the Flange should be installed facing the bow of the vessel. However, if this hinders maintenance or inspection, and there is no solution, direct the mark to the opposite (180°) direction toward the stern.

INSTALLATION

DIMENSIONS

HULL UNIT

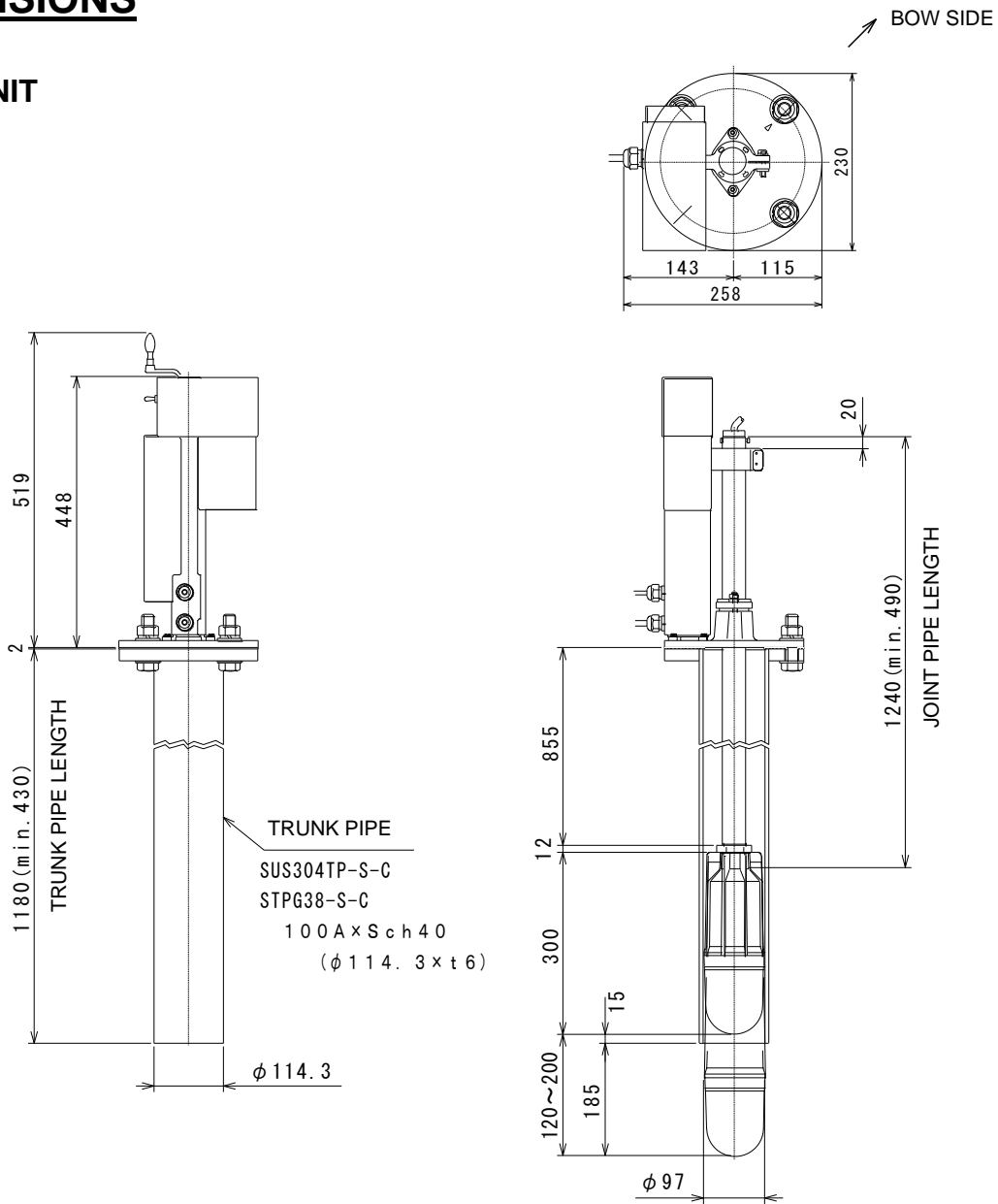

DISPLAY UNIT

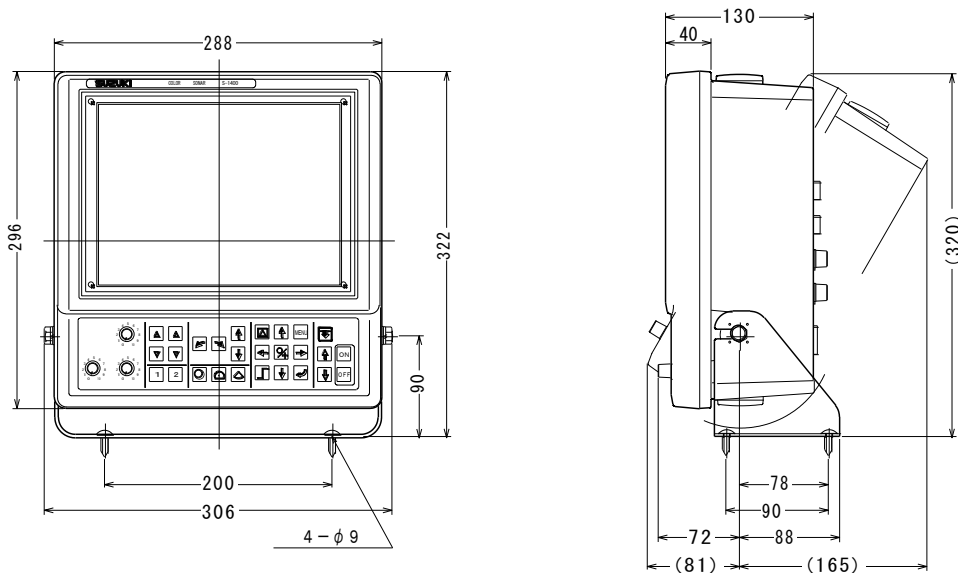

TRUNK PIPE INSTALLATION

1. MAINTENANCE SPACE

When installing the Trunk Pipe, pay full attention to the safety (strength, water-tightness, etc.). At the same time, secure a space for maintenance and inspections.

- Since the Hoist unit is not a waterproof structure, keep it away from water drops and splashes.
- S-1400 II is shipped from the factory with standard, 1,240mm Joist Pipe and without Trunk Pipe.
- When mounting the Joint Pipe to the Soundome, be sure not to damage the Joint Pipe thread or twist the Soundome cable.

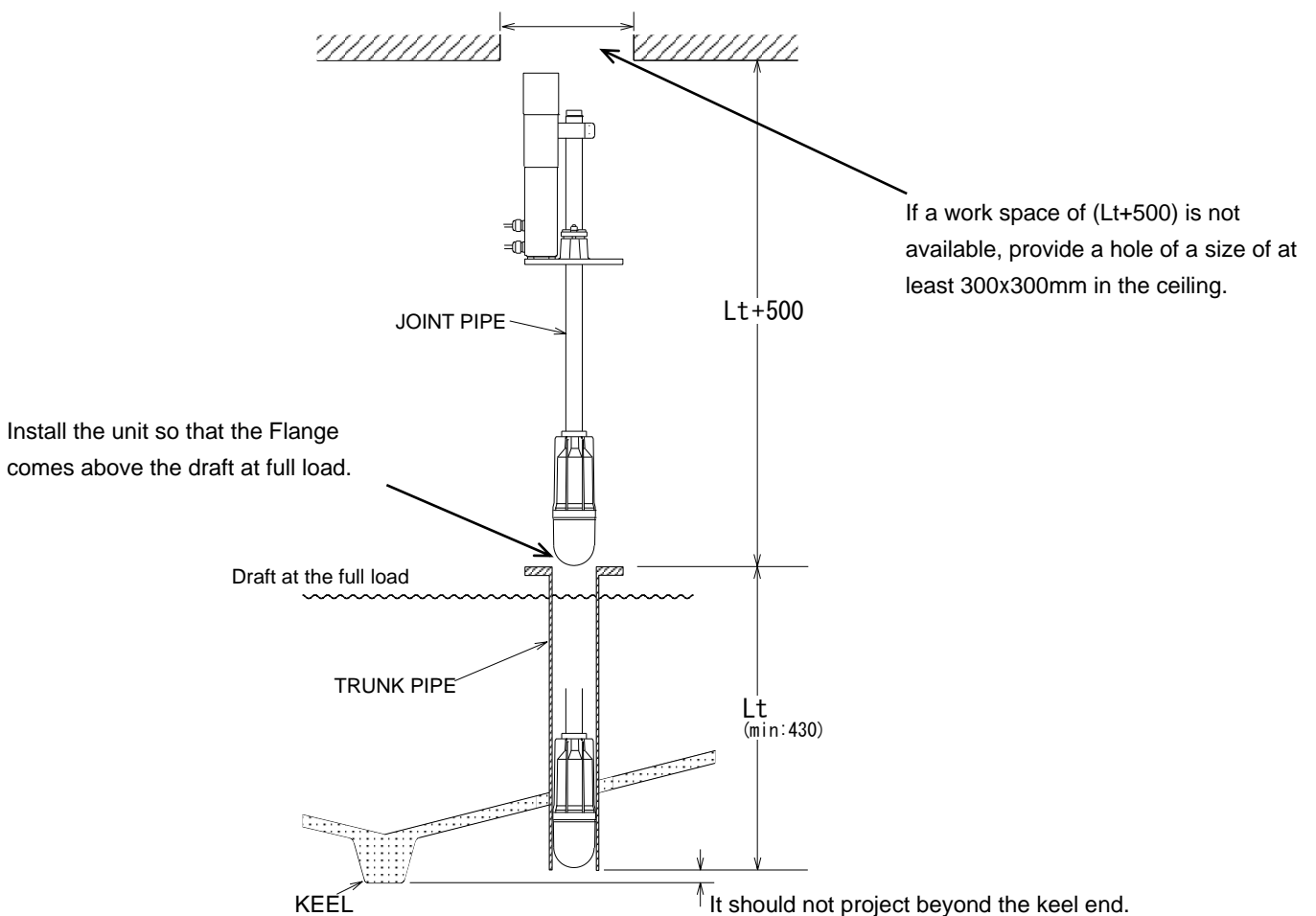

INSTALLATION

2. INSTALLATION CONDITIONS

The Trunk Pipe should be installed satisfying the following conditions.

- The position for installation should be within 1/3 to 1/2 of the overall length from the bow.
- It also should be on the keel or within 1 meter from the keel.

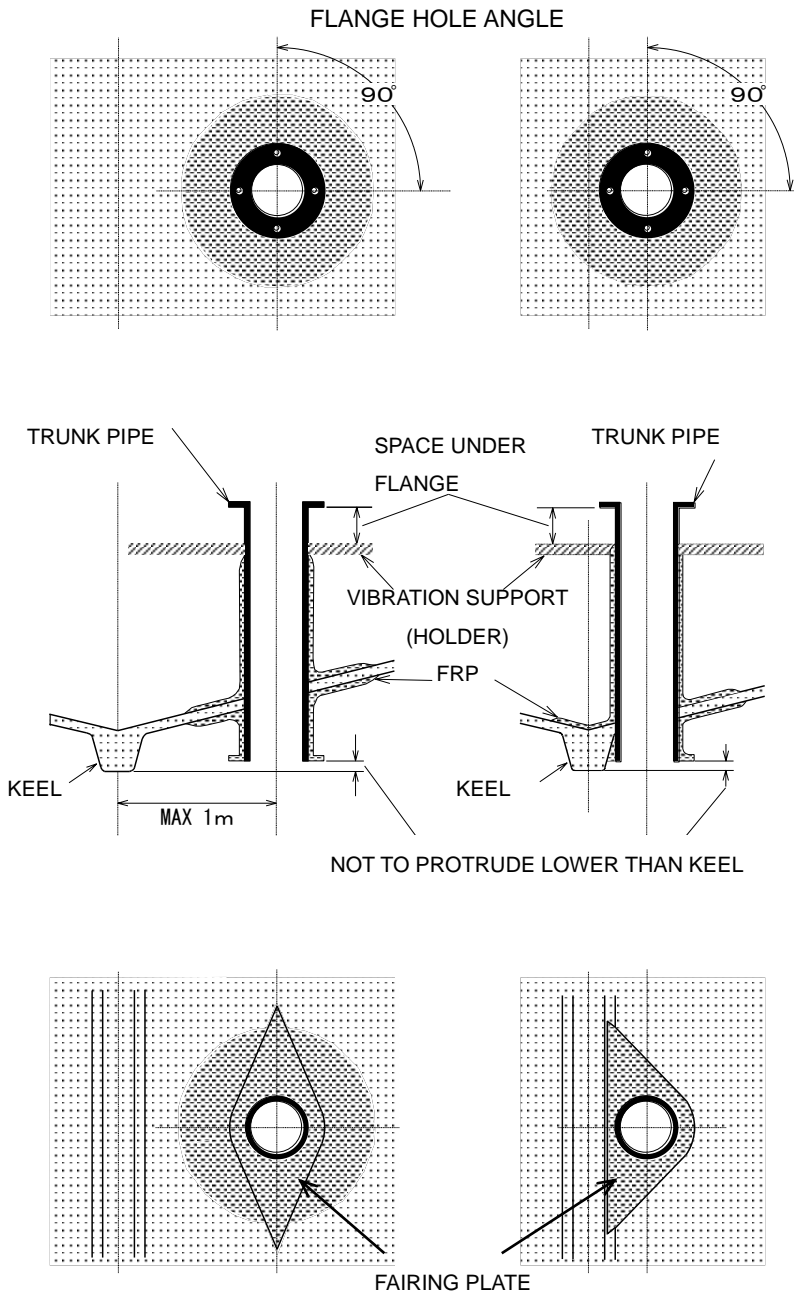

- There should be no obstacles which may interrupt bolt clamping of the Flange right below the Flange of the Trunk Pipe.
- The top end of the Trunk Pipe should not project below the keel end.
- The Flange surface of the Trunk Pipe should stay level during standard cruise.
- Apply FRP sufficiently to all the necessary sections to prevent leakage of water.
- Make the surrounding of the Trunk Pipe projecting out from the bottom in a stream-line shape, and provide a fairing plate to suppress water resistance and generation of air bubbles to the minimum.
- Install a holder to stop shaking if necessary.
- When doing this, make sure the holder does not interfere bolt clamping of the Flange.



Fully discuss about the strength and water tightness with the ship owner, the engineer in the shipyard, and the installer before determining on the position, the method of installation, and necessary materials.

HULL UNIT ASSEMBLY

1. JOINT PIPE LENGTH

Calculate necessary length of joint pipe from the length of Trunk pipe (L_t) and cut off the space portion if the shorter length than the standard 1,240mm is required.

TRUNK PIPE LENGTH (L_t)+ 60mm

2. JOINT PIPE ADJUSTMENT

If the Trunk pipe length, 1,180mm is used, no adjustment is necessary.

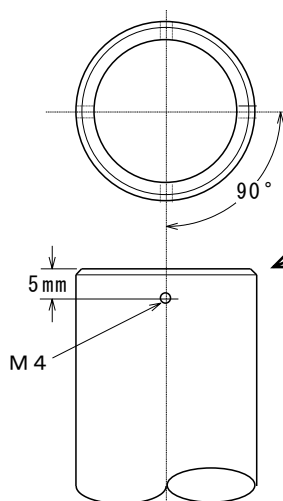

- ① Cut the Joint Pipe to the required length, Trunk Pipe Length (L_t)+60mm.
- ② Smooth the cut piece and taper the edge (1mm).
- ③ Bore 4 holes in joint pipe:
 - every 90 degrees
 - 5mm from the cut end of the pipe
 - bolt circle size, ϕ 3.4mm
 - set a tapping screw (M4) on each hole

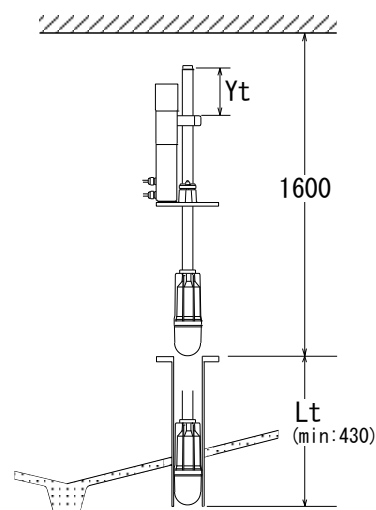
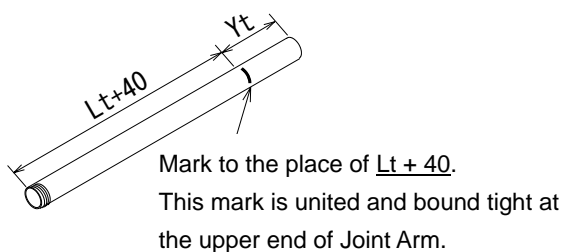

When the space above the Joint Pipe is equal to this, the Joint Pipe may be used without being cut.

INSTALLATION

3. MOUNTING JOINT PIPE INTO SOUNDOME

- When assembling the Joint Pipe into the Soundome, the Soundome must be fixed, and screw the Joint Pipe into the Soundome.
 - Be sure not to damage the Joint Pipe thread or twist the Soundome cable.
- ① - Totally wipe off dirt and grease from the threads of the Soundome and the Joint Pipe.
- Screw the Lock Nut into the thread end of the Joint Pipe. (see figure ① below)
 - ② - Pass the Soundome cable through the Joint Pipe.
- Apply some silicone adhesive (supplied) to the thread of the Joint Pipe. (see figure ② below)
 - ③ - Fully screw the Joint Pipe into the Soundome.
- Clamp the Lock Nut to the Soundome.
- Coat the Lock Nut and the Joint Pipe with silicone adhesive (supplied).
- Apply the bow mark at the top end of the Joint Pipe. (see figure ③ below)

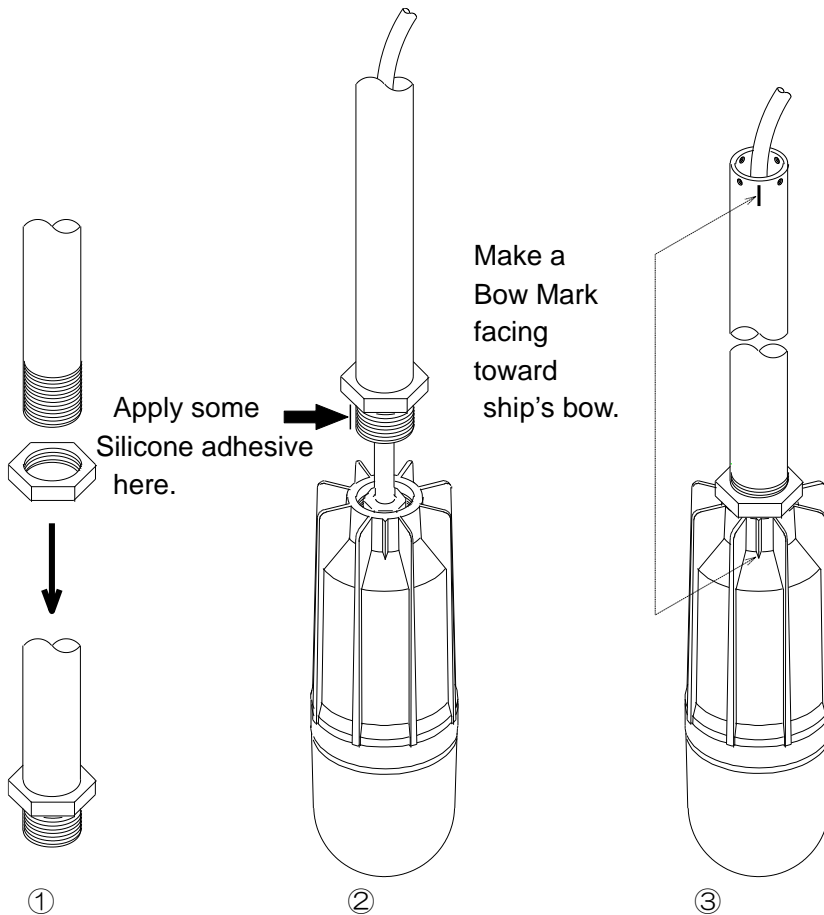

Care not to damage the Soundome cable should be taken.
Screw or unscrew the joint pipe when mounting the joint pipe into the Soundome or dismounting it.
Screwing the cable causes the damage of the Soundome or its cable.

4. ATTACHING SOUNDOME TO HOIST

- Apply grease to the Flange bearing (figure ①) where the Joint Pipe is passed through.
- Pass the Damper (figure ②) through and mount it into the Joint Arm (figure ③) facing the bow mark toward ship's bow.
- Ensure that the Joint Pipe end projects 20mm from the Joint Arm surface.
- In case of the length of the Trunk Pipe other than 1,180mm long, ensure the lowest part of the Soundome is at least 15mm above the lowest part of the Trunk Pipe.
- To prevent slip-out of the Joint Pipe, fasten the Fastening Band (figure ④).
- Pass the cable through the Pipe Cap.
- Insert the Pipe Cap in the end of the Joint Pipe, and fix evenly with four Cap Bolts.

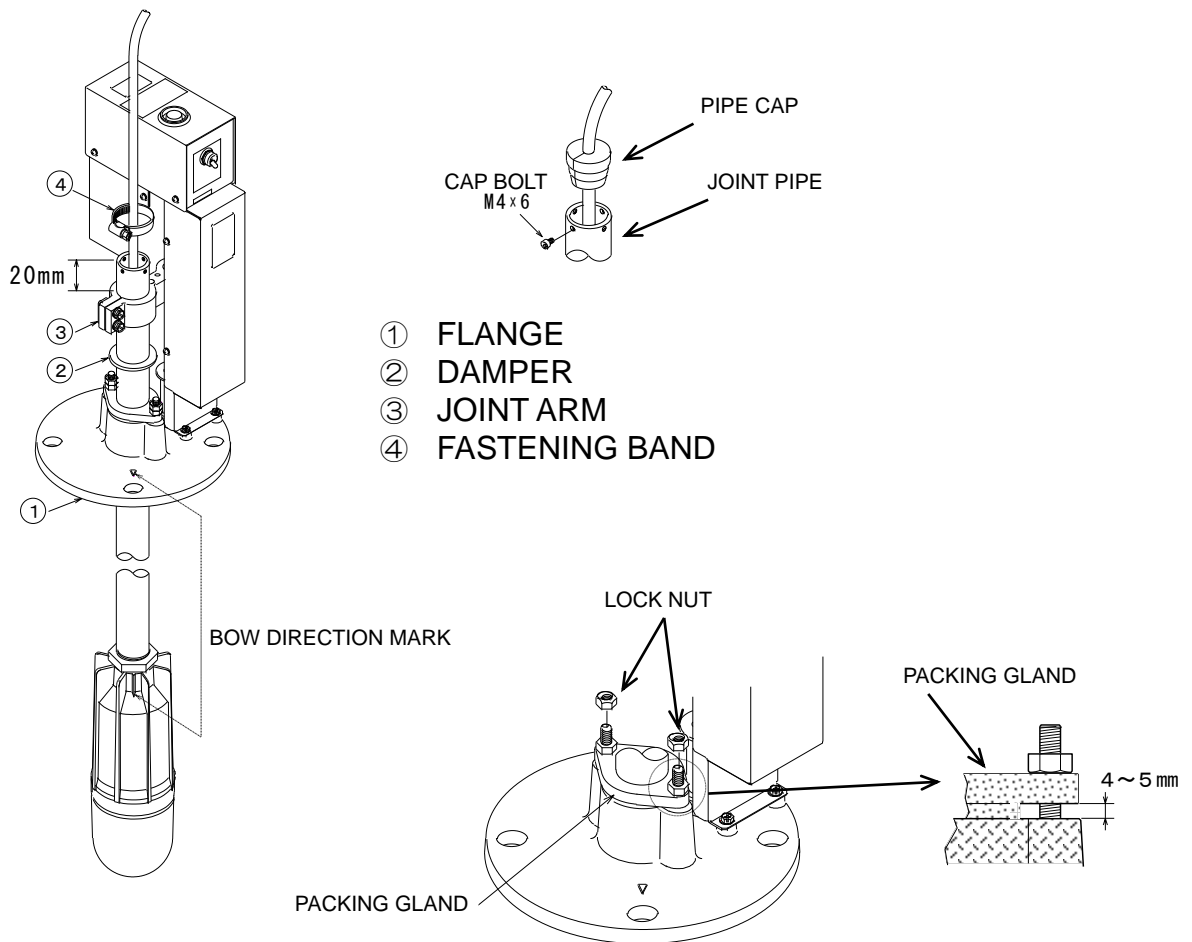

ADJUST THE PACKING GLAND

- Remove the upper Lock Nuts from the Packing Gland.
- Tighten the lower Lock Nuts until the space of the Packing Gland becomes 4 to 5mm.
- Make both side of spaces become the same.
- Put the removed upper Lock Nuts back. Clamp them tightly.
- In case of the water leakage after returning the ship to the water, the same procedure as described above is required again.

INSTALLATION

5. HULL UNIT AND TRUNK PIPE ATTACHMENT

- Use 4 Hexagonal Bolts (M20x80) to fit the Hull Unit to the Trunk Pipe.
- Make tentative clamp and try to move the Soundome up and down for several times to confirm the alignment when making the final clamping evenly.
- The Hoist can be operated manually. (Refer to the page 4-11)

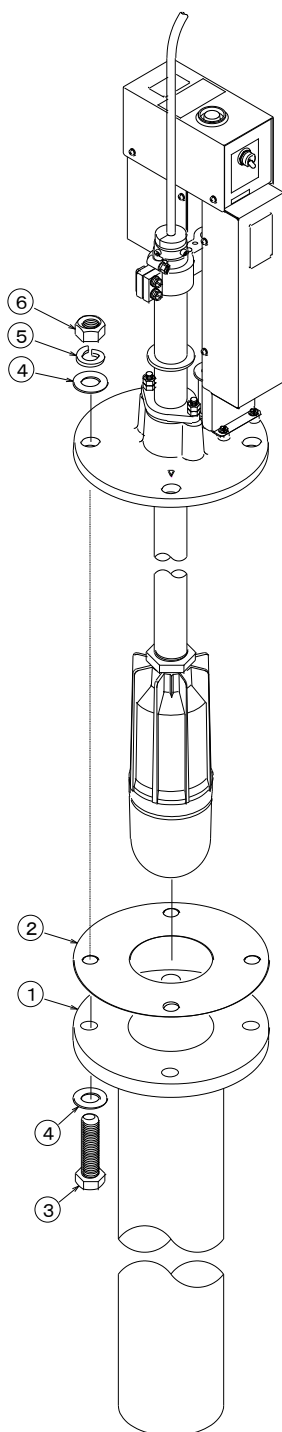

- ① TRUNK PIPE
- ② GASKET
- ③ HEXAGONAL BOLT (M20X80)
- ④ FLAT WASHER (Φ20X40X3)
- ⑤ SPRING WASHER (Φ20)
- ⑥ HEXAGONAL NUT (M20)



Do not apply any adhesive on the Gasket.
Otherwise it disturbs being clamped evenly.

ADJUSTMENT OF HOIST STROKE

The stroke can be adjusted from 120mm at the minimum to the 200mm at the maximum by changing the position of the Limit Switches.

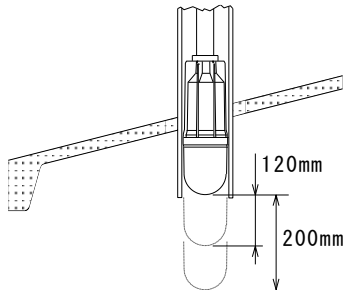

Turn off the power for the motor before adjusting the Limit Switches.

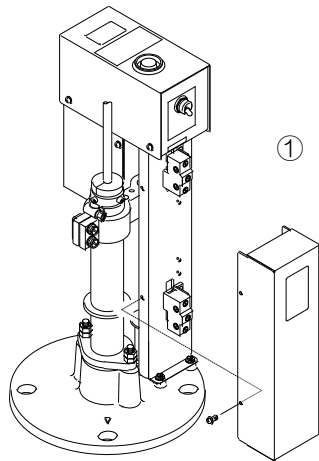

- Remove 4 screws and open the cover so that the Upper/Lower Limit Switches are seen. (figure ①)

- The Upper Limit Switch indicates the upper end.
- The Soundome stops raising when the Joint Arm reaches here.

- The Lower Limit Switch indicates the lower end.
- The Soundome stops lowering when the Joint Arm reaches here.

- The initial set position of the stroke is 200mm.

- Change the position of the Limit Switch when the adjustment of the stroke is required. (figure ②)

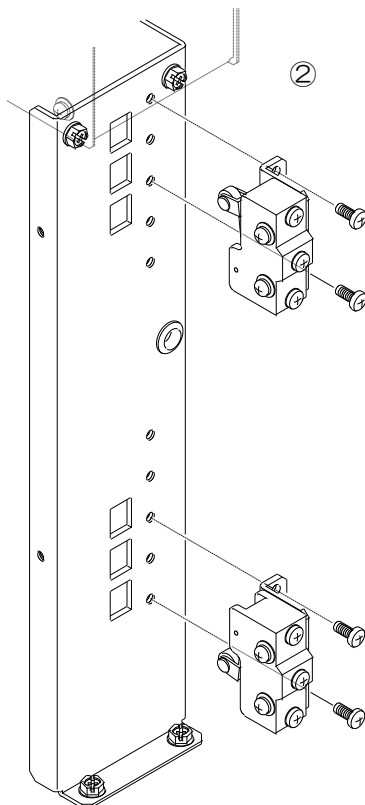

- Shift the position of the Upper Limit Switch to the third hole from the top and Lower Limit Switch to the third hole from the bottom so that 120mm of the stroke can be provided.

- Pay attention to the direction of the switches when shifted.

- The retracted Soundome should be at least 15mm above the lowest part of the Trunk Pipe when the position of the Upper Limit Switch is shifted.

- If not, adjust the position of the Joint Pipe upward with the Joint Arm loosen.

- The position of the retracted Soundome and its stroke can be confirmed manually.

- Refer to the next page “MANUAL RAISE/LOWER OF SOUNDOME.”

INSTALLATION

MANUAL RAISE/LOWER OF SOUNDOME

The Soundome can be raised or lowered manually when mounting the Hoist and the Trunk Pipe or adjusting the stroke.

The manual operation is also available in case of a trouble that the Soundome can not be raised or lowered automatically.

- If the power is supplied, make sure to turn off the power of the hoist motor and remove the Protective Cap when raising or lowering the Soundome.
(Refer to the drawings below)
- Insert the Crank Handle (supplied) into the hole where the Protective Cap was attached and raise or lower the Soundome with the Crank Handle.
(Refer to the drawings below)

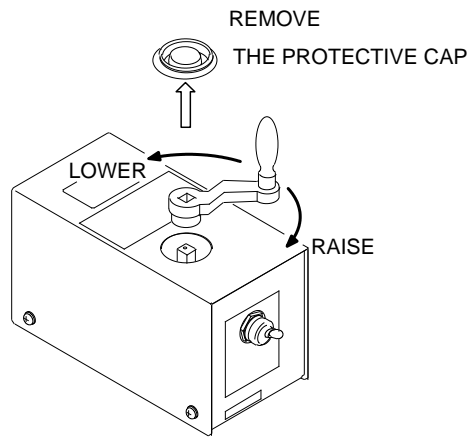
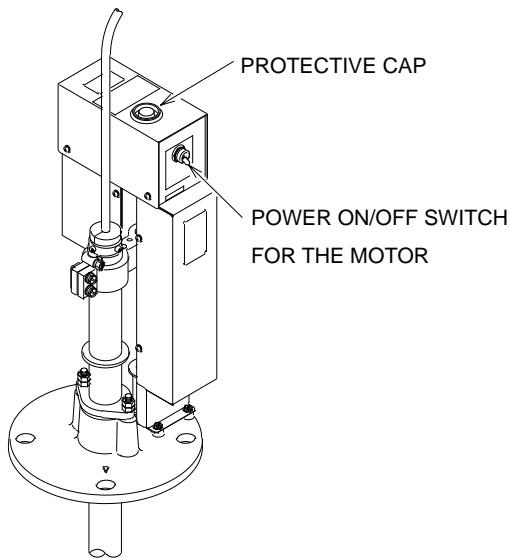

- After finishing the work, remove the Crank Handle and put the removed Protective Cap back. Do not forget to turn on the power for the motor.



Turning off the power for the display unit does not mean turning off the power for the motor.

Make sure to turn off the power for the motor before manual raising/lowering. Otherwise it may cause trouble that the motor runs and the Crank Handle may rotate in reverse.

The brake is working while the power supply is not supplied to the hoist motor. It is hard to turn the Crank Handle while the power supply is not supplied to the hoist motor, however after both upper and lower limit switches are released, it will be turned easily.

MOUNTING METHOD OF DISPLAY UNIT

- ① Fasten the Bracket to the place you selected with 4 tapping screws.
- ② Screw the Knob Bolts to the hole on both sides of the Display Unit.
- ③ Insert the Display Unit into the Bracket.
- ④ Adjust the Knob Bolts to select a comfortable viewing angle of the Display Cabinet.

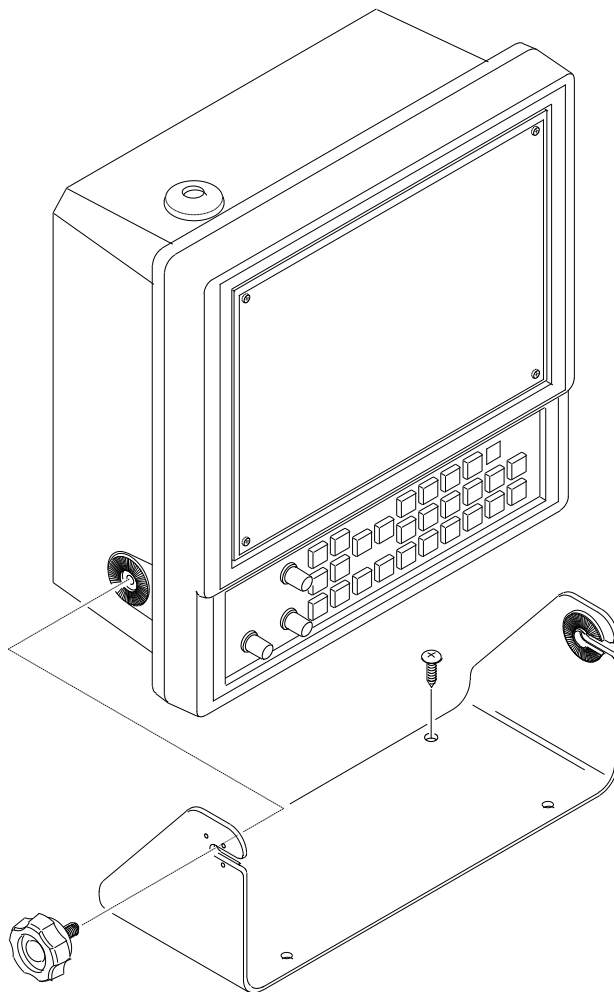

Do not install the unit on unstable or uneven surface.

Do not use the unit while tentatively mounted. Otherwise it may result in the unit falling or toppling over, resulting in injury.



Be free as much as possible from shocks and engine vibrations.

Mount the unit in a location away from salt spray, heat sources, and direct sunlight.

INSTALLATION

CONNECTIONS

Prior to the connections between the Display Unit and the Hull Unit, read the following warning carefully to ensure its correct operation.



- Operating voltage: 20 to 30 volts DC
- Use the correct voltage, otherwise it will result in fire or electrical shock.
- Use the specified power supply cables.
- If not, it could result in serious trouble or fire.
- Always turn off the power before connecting or disconnecting the unit.
- Pulling the cables may damage the cables themselves and result in fire or electrical shock.
- Bring wiring to the following attention to avoid getting hurt or causing fire or damage.
- Run the cables not to touch the rotary obstacles or disturb the operation.
- Do not use the cables bent, twisted or stretched by force.
- Do not put heavy objects on the cables.

WIRING AMONG UNITS

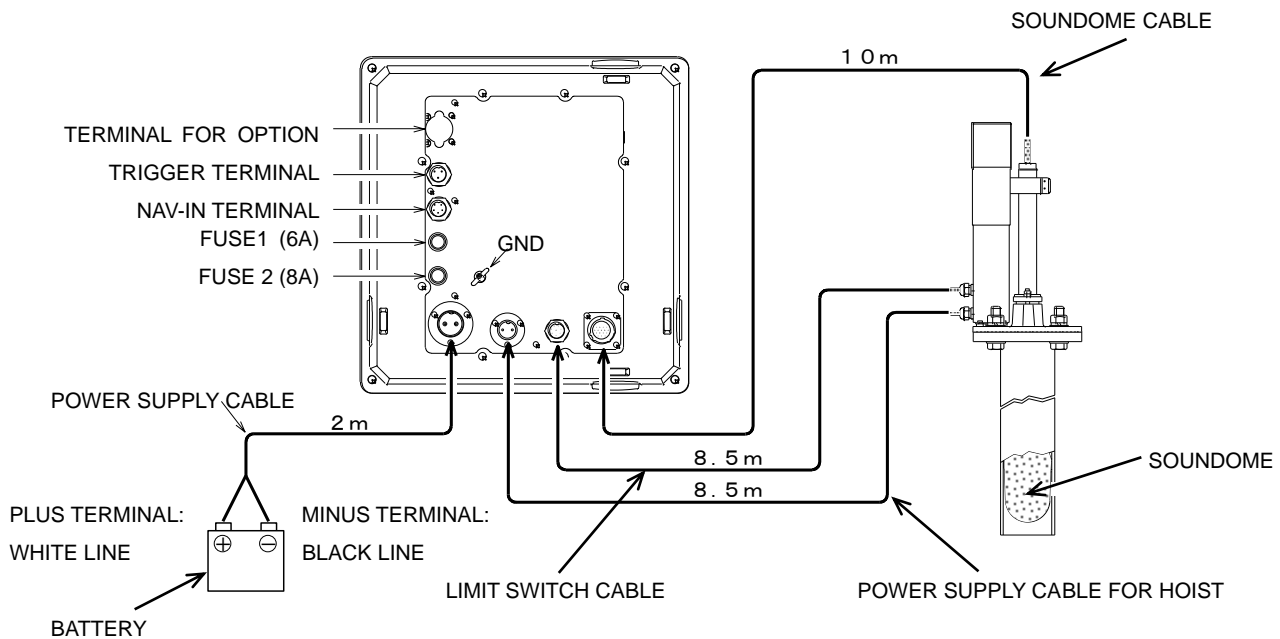

- Turn off the power by [OFF] key on the control panel.
- Do not turn off the power by the switch-board or the breaker.
- Confirm the retraction of Soundome and the power of the Display Unit is turned off before turning off the switch-board or the breaker.
- Use the proper fuses.

ELECTRICAL CONNECTIONS - TERMINALS

Explanation of the Terminals on the rear of the Display Unit.

TRIGGER OUTPUT TERMINAL

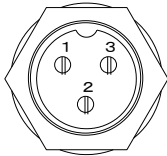

- 1: TRIGGER OUTPUT +
- 2: GND
- 3: TRIGGER OUTPUT -

TRIGGER OUTPUT CIRCUIT

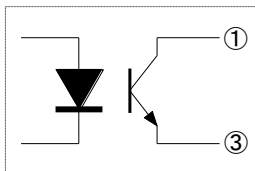

NAV-IN TERMINAL

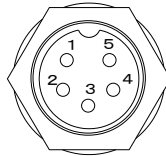

- 1: SIGNAL INPUT +
 - 2: SIGNAL INPUT -
 - 3: GND
 - 4: NC
 - 5: NC
- (Do not connect anything to NC)

LIMIT SWITCH TERMINAL

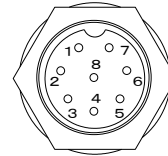

- 1: UPPER LIMIT SWITCH
- 2: UPPER LIMIT SWITCH
- 3: LOWER LIMIT SWITCH
- 4: LOWER LIMIT SWITCH
- 5: SENSOR LAMP LED SWITCH
- 6: SENSOR LAMP LED SWITCH
- 7: SENSOR LAMP LED
- 8: SENSOR LAMP LED

POWER SUPPLY INPUT TERMINAL

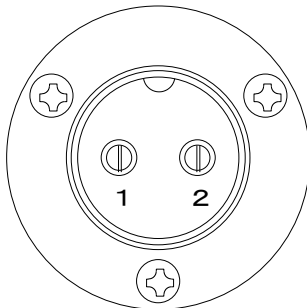

- 1: DC INPUT +
- 2: DC INPUT -

SOUNDOME TERMINAL

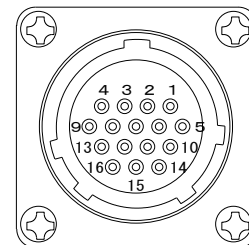

- 1: GND
- 2: +12V
- 3: HALL IC OUTPUT
- 4: TRAIN MOTOR 1
- 5: TRAIN MOTOR 2
- 6: TRAIN MOTOR 3
- 7: TRAIN MOTOR 4
- 8: TRAIN COM (+12V)
- 9: TILT MOTOR 1
- 10: TILT MOTOR 2
- 11: TILT MOTOR 3
- 12: TILT MOTOR 4
- 13: TILT COM (+12V)
- 14: TRANSDUCER
- 15: GND
- 16: TRANSDUCER

HOIST MOTOR OUTPUT TERMINAL

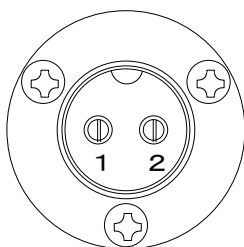

- 1: DC OUTPUT (+) / (-)
- 2: DC OUTPUT (-) / (+)

UPLOADING / DOWNLOADING

Chapter 5

OPTION

This chapter provides you the explanation related to the optional kits.

OPTION.....	5 - 2
REMOTE CONTROLLER.....	5 - 3

OPTION

The S-1400 II is designed to interface with the remote controller or the VGA output or the Audio output. (*optional kit is required)

- The interface kit is the terminal which connects the inner board and external equipment.

Parts No.	NAME	MEMO
OP-347	Remote Controller interface kit	the connector plate included
CRC-202	Remote Controller	the cable included
OP-348	Audio output terminal kit	the connector plate included
OP-603	Audio Box	the audio cable included the audio plug included
OP-340	VGA output terminal kit	the connector plate included

- OP-603 does not include an audio speaker (4 ohm) and a speaker cable.
- OP-340 does not include a connector cable.

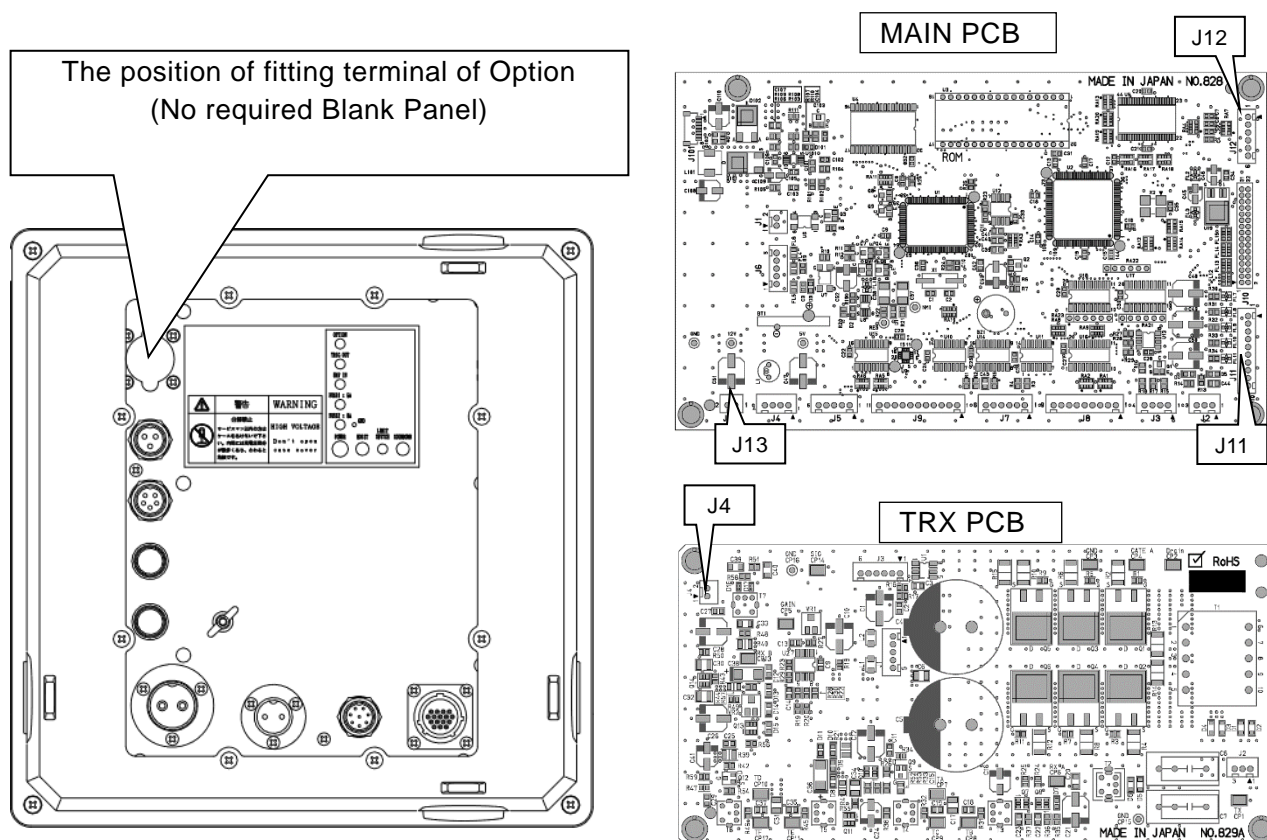

REMOTE CONTROLLER

Remote controller connection is made to the terminal on the rear of the display unit.

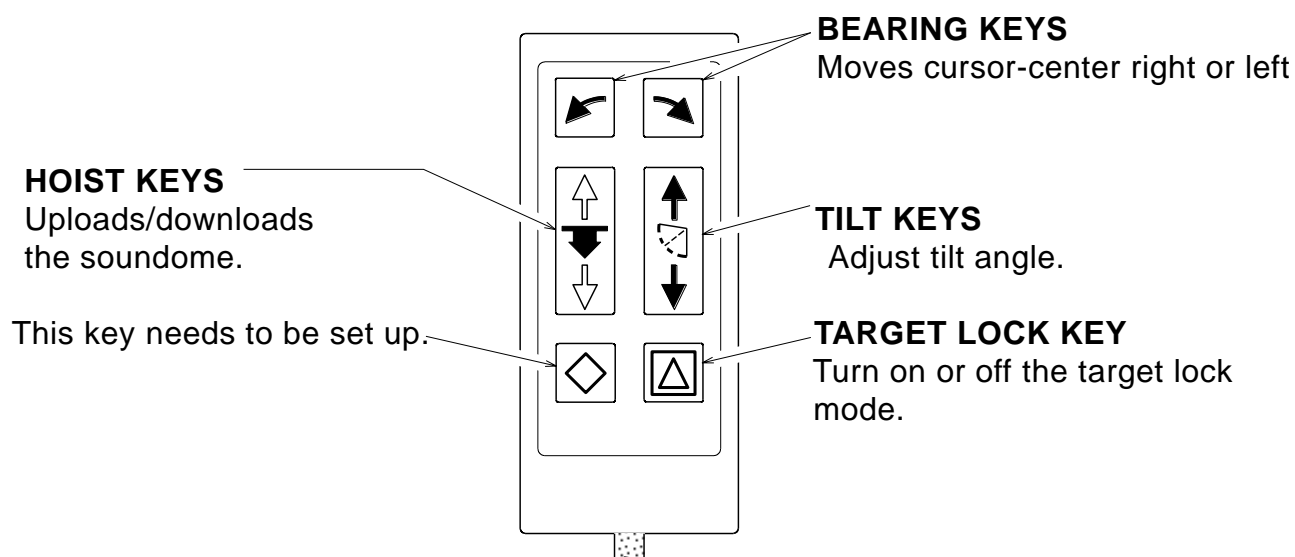

OPTION

REMOTE CONTROLLER SETTING

1. Press MENU KEY. "MENU" appears on the screen.
2. Use the cursor shift key 「↑」 or 「↓」 to highlight "REMOTE CONTROLLER SET" and by pressing the cursor shift key 「←」 or 「→」 the following appears on the screen.

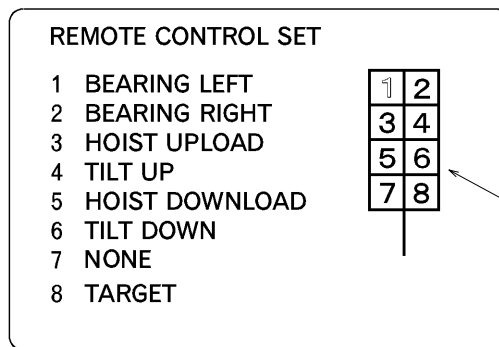

- Use the cursor shift key 「↑」 or 「↓」 to select the desired item.

Remote controller keys

- The above box shows the initial settings of the remote control keys.
- Highlighting the item to be changed and pressing the cursor shift key 「←」 or 「→」 the keyoperation will change as follows.

RENGE SHALLOW → RANGE DEEP → SECTOR WIDE → SECTOR NARROW → DISPLAY MODE* → OPERATION MODE 1 → OPERATION MODE 2 → TARGET → THRESHOLD → CURSOR SELECTION → CURSOR SHIFT UP → CURSOR SHIFT DOWN → CURSOR SHIFT RIGHT → CURSOR SHIFT LEFT → NONE → HOIST UPLOAD → HOIST DOWNLOAD → TILT UP → TILT DOWN → BEARING RIGHT → BEARING LEFT

- DISPLAY MODE* means that each press of the key changes the mode as follows.

SONAR MODE → OFF CENTER MODE → BOTTOM SCAN MODE → ECHO SOUNDER MODE → SONAR MODE

- Press ENTER KEY to finish the setting.
Press MENU KEY to escape the setting.

APPENDIX

This chapter describes you the daily maintenance, disposal, and specifications of S-1400 II Sonar. It also provides a memo of operation mode.

DAILY MAINTENANCE..... 6 - 2

DISPOSAL..... 6 - 3

SPECIFICATIONS..... 6 - 4

MEMO OF OPERATION MODE..... 6 - 5

DAILY MAINTENANCE

CLEANING DISPLAY UNIT

Wipe off dust or salt crystals from the filter lightly with a soft wet cloth.

- Using a dry or firm cloth may scratch the surface of display. Display with many scratches shows the poor visibility of the screen.
- Do not use any chemical cleaners to clean the S-1400 II Sonar.
- Make sure to turn off the power before cleaning. Breathe out on the surface, and wipe off dust from LCD display lightly with an absorbent cotton or clean soft cloth after removing the filter.
If there is dust you can not wipe away, contact your local dealer or SUZUKI head office.

APPLYING GREASE

Apply grease regularly to the Hoist Gears (figure A) and the Flange Opening (figure B). Otherwise it may damage the unit.

- You can apply grease to the Hoist Gears easily when the Soundome is in down position. Apply grease to the Flange Opening when the Soundome is uploaded.

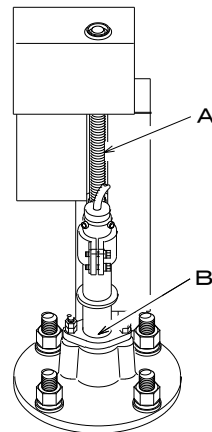

CLEANING SOUNDOME

Since Soundome is installed in the bottom of the vessel, barnacle and oyster stick to the Soundome. These barnacle and oyster disturb the smooth operation of the unit.

- At the dry dock, remove oyster and barnacle sticking to the Trunk Pipe and the Soundome.
Do not scratch the Soundome while removing them.
- Do not paint the Soundome. Otherwise it will result in poor sonar performance.



This equipment contains the lithium battery of high-density energy.

Careless disposal of the lithium battery causes electric shorts, impact, generation of heat, electrical shock, explosion, injury, or fire.

DISPOSAL of EQUIPMENT

Dispose of this equipment in accordance with local regulations.

DISPOSAL of LITHIUM BATTERY

Before disposing of the lithium battery, place a piece of adhesive tape across the plus and minus terminals as non-combustible garbage.

Dispose of the lithium battery in accordance with local regulations.

SPECIFICATIONS

DISPLAY

Display	10.4 " (TFT) Color LCD (640 x 480 pixels)
Power Supply	20 ~ 31.2 VDC 70W
Weight	5.8kg
Sonar Type	Searchlight Sonar
Display Range	
Unit	Meter
	0 – 10 – 100 (10 steps) 100 – 300 (20 steps)
	Fathom
	0 – 10 – 200 (10 steps)
	Feet
	0 – 50 – 1000 (50 steps)
Scanning Step Angle	
Sonar Mode	(5° step) 5° 25° 45° 85° 125° 165° 205° 360°
	(10° step) 10° 30° 50° 90° 130° 170° 210° 360°
Bottom Scan Mode	(3° step) 3° 27° 45° 63° 93° 117° 147° 177°
	(5° step) 5° 25° 45° 65° 95° 115° 145° 175°
Bearing Center	selectable in step of 5°
Tilt Angle Range	5° ~ 0° ~ -90° (1° step)
Display Modes	Sonar Mode + Data Display / Off-Center Mode + Data Display / Bottom Scan Mode + Data Display / Echo Sounder Mode + Data Display
Data Display	Range, Range Scale, Tilt Angle, Tilt Angle Diagram, Sector Angle Display, Bearing Angle, Ring Marker (Historical Distance, Slant Distance, Depth), Gain Up, TVG Graph, Cross Cursor (Bearing, Historical Distance, Slant Distance, Depth), Interference Reduction, Color Scale, Compass Display,* Ship Speed, * LAT/LON,* Temperature,* Scan Display (2 types), Own Ship Position, VRM, Depth (on detecting just below the ship)
Other Functions	Operation Modes (2 x 2 types), Off-Center (4 types), Target Lock, Train Correct, Gain Control, TVG Control, Dynamic Range, Pulse Width, Color Selection, Output Power Reduction, Interference Reduction, Noise Reduction, Threshold Control, Gain, Far Gain, Brightness Control, Sensor Lamp, Hoist Auto Up, Stabilizer
Input Data*	NMEA-0183 (LAT/LON, Ship Speed, Compass Display, Temperature) Remote Controller*
Output Data*	Trigger Signal, VGA*, Audio*

*Optional interface required.

HULL UNIT

Frequency	220kHz
Sonar Type	Searchlight Sonar
Hoist Stroke	120 ~ 200mm
Hoist Time	Approx.7 seconds (200mm stroke, 24V supply)
Raising/Lowering the Soundome	Automatically Soundome raised and lowered with the power ON/OFF linked
Weight	17kg (without Trunk Pipe)

MEMO OF OPERATION MODE

MENU AND OPERATION PANEL

FUNCTIONS	FACTORY SETTINGS (item in the box)	0-1	0-2	1-1	1-2
FUNCTION SET					
GAIN UP	<input type="checkbox"/> OFF · +10dB · +20dB · +30dB · +40dB				
TVG CURVE	OFF · 10LOG · 20LOG · <input type="checkbox"/> 30LOG · 40LOG				
DYNAMIC RANGE	1dB · 2dB · <input type="checkbox"/> 3dB				
PULSE WIDTH	NARROW · <input type="checkbox"/> NORMAL · WIDE · 0.3ms				
TX POWER	LOW · <input type="checkbox"/> HIGH				
REDUCTION					
INTERFERENCE RED.	<input type="checkbox"/> OFF · 1 · 2 · 3				
NOISE REDUCTION	<input type="checkbox"/> OFF · ON				
DISP ITEM SEL.					
STEP (SONAR)	5° · <input type="checkbox"/> 10°				
STEP (BOTTOM SCAN)	3° · <input type="checkbox"/> 5°				
OFF-CENTER POS.	<input type="checkbox"/> FORE · BACK · RIGHT · LEFT				
SCALE DOTS	OFF · <input type="checkbox"/> ON				
COMPASS DISP.	<input type="checkbox"/> OFF · ON				
OTHERS					
TARGET LOCK	<input type="checkbox"/> MODE 0 · MODE 1 · MODE 2				
OPERATION MODE	<input type="checkbox"/> 0 · 1				
DEPTH UNIT	<input type="checkbox"/> m · br · fm · ft				
TEMP. UNIT	<input type="checkbox"/> °C · °F				
SPEED UNIT	<input type="checkbox"/> Kt · km/h				
HOIST AUTO UP (SPEED UNIT: kt)	<input type="checkbox"/> OFF · 1kt ~ 15kt				
(SPEED UNIT: km/h)	<input type="checkbox"/> OFF · 1km/h ~ 27km/h				
TRAIN CORRECT	<input type="checkbox"/> 0° ~ 355°				
COLOR	<input type="checkbox"/> A-1 · A-2 · B-1 · B-2 · C-1 · C-2 D-1 · D-2				
FILTER	<input type="checkbox"/> OFF · 1 · 2				

		0-1	0-2	1-1	1-2
RANGE	Sonar Mode				
	Bottom Scan Mode				
	Echo Sounder Mode				
SECTOR ANGLE	Sonar Mode				
	Bottom Scan Mode				
TILT ANGLE	Sonar Mode				
	Bottom Scan Mode				
	Echo Sounder Mode				
BEARING CENTER	Sonar Mode				
	Bottom Scan Mode				
	Echo Sounder Mode				

