

6-pin Deutsch connector

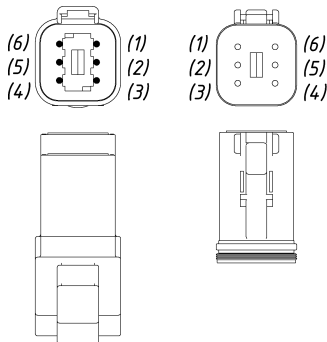

- (1) - CAN1 LOW, Green or Blue
- (2) - CAN2 LOW, Brown
- (3) - CAN1 HIGH, Yellow
- (4) - GND (negative supply, ground), Black
- (5) - CAN2 HIGH, White
- (6) - VCC (positive supply, 10..30V), Red

Pins (2) and (5) are not connected to the Device.

Figure 2. Engine connectors, DT04-6P (male, left) and DT06-6S (female, right)

In the jumper plug supplied with the Device, contacts (1) and (2) as well as contacts (3) and (5) are interconnected. In this way, CAN1 and CAN2 are united into a single network (applicable for Volvo Multilink bus only). Contacts (2) CAN2 LOW and (5) CAN2 HIGH are not connected to the Device.