

# OWNER'S GUIDE & INSTALLATION INSTRUCTIONS

In-Hull: *Adjustable-angle*

## Depth Transducer

Models: **P79, P79S Smart™ Sensor**  
Chirp Models: **P75M, P95M**

Patent <http://www.airmar.com/patent.html>

07/18/18

17-217-01 rev. 15

**Follow the precautions below for optimal product performance and to reduce the risk of property damage, personal injury, and/or death.**

**WARNING:** Always wear safety glasses, a dust mask, and ear protection when installing.

**CAUTION: Chirp transducer**—Always operate the transducer in liquid. Operating in air will allow the transducer to overheat resulting in failure.

**CAUTION: Fiberglass hull**—The fiberglass hull below the transducer must be **SOLID**. The transducer will not transmit through coring material such as foam or balsa wood.

**CAUTION: Chirp transducer**—Do not install in the engine compartment or other hot place. The transducer may fail if the temperature of the liquid in the tank exceeds 60° C (140° F).

**CAUTION:** Never pull, carry, or hold the transducer by the cable. This may sever internal connections.

**CAUTION:** Do not use an epoxy adhesive because it is too brittle.

**CAUTION:** Never use solvents. Cleaner, fuel, sealant, paint, and other products may contain solvents that can damage plastic parts, especially the transducer's face.

**IMPORTANT:** Please read the instructions completely before proceeding with the installation. These instructions supersede any other instructions in the instrument manual if they differ.

## Applications

- For fiberglass hulls *only*
- Recommended for high-speed powerboats and racing sailboats
- Accommodates a deadrise angle from 2° to 22°

## Tools & Materials

Safety glasses  
Dust mask  
Ear protection  
Adhesive tape  
Pole  
Detergent (some installations)  
Weak solvent (such as alcohol)  
Disk sander (some installations)  
Thin sealable plastic bag (some installations)  
Cable ties (some installations)  
Water-based lubricant (such as K-Y® Jelly) (some installations)  
Angle finder

Record the information found on the cable tag for future reference.

Part No. \_\_\_\_\_ Date \_\_\_\_\_ Frequency \_\_\_\_\_ kHz

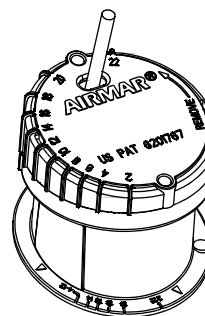

- Carpenter's square
- Pencil
- Silicone sealant (such as GE® Silicone I or Silicone II)
- Screwdriver
- Petroleum jelly
- Propylene glycol (non-toxic antifreeze/coolant) 71 ml (2.4 fl. oz.)
- Level
- Grommet(s) (some installations)
- Installation in a cored fiberglass hull (page 4):
  - Electric drill
  - Hole saw 100mm or 4"
  - Miniature disk sander (such as Dremel® rotary sander)
  - Repair epoxy (such as Pettit Flexpoxy 7076) or resin
  - Paper cup (some installations)
  - Stirrer (some installations)

## Mounting Location

### About Fiberglass Hulls

The fiberglass hull below the transducer must be solid. Since the hull absorbs acoustic energy, transmitting through the hull reduces the transducer's performance. Fiberglass hulls are often reinforced in places for added strength or to reduce weight. These cored areas contain balsa wood or structural foam which are poor sound conductors. **Do not locate the transducer over coring.**

### Placement

**CAUTION:** Do not mount the transducer in line with or near water intake or discharge openings or behind strakes, fittings, or hull irregularities that will disturb the water flow.

Choose a location:

- Where the fiberglass is **SOLID** (no air bubbles are trapped in the fiberglass resin) and where no coring, flotation material, or dead air space is sandwiched between the inside skin and outer skin of the hull.
- Where the hull below the transducer will be in contact with the water at all times.
- Where the water flowing under the hull is smoothest with a minimum of bubbles and turbulence (especially at high speeds).
- Away from interference caused by power and radiation sources such as: the propeller(s) and shaft(s), other machinery, other echosounders, and other cables. The lower the noise level, the higher the echosounder gain setting that can be used.
- Where the transducer beam will not be blocked by the keel or propeller shaft(s).
- Where the deadrise angle does not exceed 22°.
- Where there is space inside the vessel for the height of the unit, tightening the locking ring, and installing the transducer.
- **Chirp transducer**—Mount in a cool well-ventilated area away from the engine to avoid overheating. The transducer may fail if the temperature of the liquid in the tank exceeds 60° C (140° F).

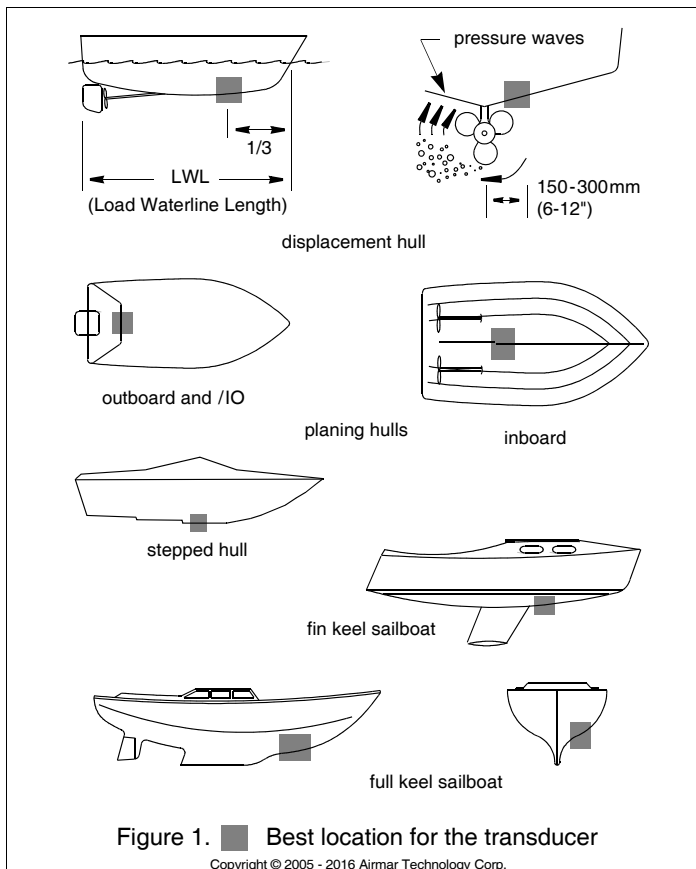

Figure 1. ■ Best location for the transducer

Copyright © 2005 - 2016 Airmar Technology Corp.

### Boat Types (Figure 1)

- **Displacement hull powerboat**—Locate 1/3 of the way back along the LWL and 150–300mm (6–12") off the centerline. The side of the hull where the propeller blades are moving downward is preferred.
- **Planing hull powerboat**—Mount well aft, on or near the centerline, and *well inboard of the first set of lifting strakes* to ensure that the transducer is in contact with the water at high speeds. The side of the hull where the propeller blades are moving downward is preferred.  
**Outboard and I/O**—Mount just forward of the engine(s).  
**Inboard**—Mount well ahead of the propeller(s) and shaft(s).  
**Stepped hull**—Mount just ahead of the first step.
- **Fin keel sailboat**—Mount to the side of the centerline and forward of the fin keel 300–600mm (1–2').
- **Full keel sailboat**—Locate amidships and away from the keel at the point of minimum deadrise angle.

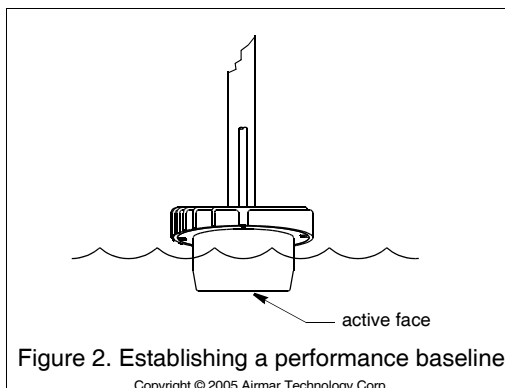

Figure 2. Establishing a performance baseline

Copyright © 2005 Airmar Technology Corp.

## Testing the Selected Mounting Location

### Establishing a Performance Baseline

The results of this test are used as a basis of comparison to determine the best in-hull location for the transducer.

1. Take the boat to the maximum depth in which you will be operating the echosounder. If deep water is not available, find a location with at least 30m (100').
2. Connect the transducer to the echosounder.
3. Tape the transducer to a pole with the cable side up. Hold it over the side of the boat with the active face fully submerged and parallel to the water surface (Figure 2).
4. Observe the echosounder's performance and the depth reading.

### Testing the Location

While the boat is at the same site (depth of water), test the transducer inside the hull at the mounting location. Use one of the methods below:

- A. For a location near the stern and a minimal deadrise angle**—Clean away any build-up of dirt and/or grease using detergent or a weak solvent such as alcohol. Place the transducer against the hull and allow bilge water to cover the surface where they touch (Figure 3-A).
- B. For a moderate deadrise angle**—If the hull surface is not smooth, grind it with a disc sander. Place the transducer inside a thin plastic bag. Partially fill the bag with water and close it tightly with a cable tie. Wet the surface of the hull and press the active face of the transducer against it through the bag (Figure 3-B).
- C. For any location**—If the hull surface is not smooth, grind it with a disc sander. Coat the active face of the transducer with a water-based lubricant (such as K-Y® jelly). With a twisting motion, press the face firmly against the hull (Figure 3-C). After testing, wipe all traces of the lubricant from the transducer's face.

Observe the echosounder's performance, and compare it to the baseline. Look for a stable depth reading that is similar to the baseline. Compare the thickness and intensity of the bottom trace.

If the performance is close to the baseline, this is a good mounting location. Remember, some energy is lost transmitting through the hull. If the test reading differs markedly from the baseline, you will need to find another location to install the transducer.

**NOTE: Fiberglass hull**—If there is no reading or it is erratic, the transducer may be positioned over coring which is absorbing the acoustic energy. Choose another location. If no other location is available, check with the boat manufacturer to be certain coring is present before proceeding with the instructions for "Installation in a Cored Fiberglass Hull" (page 4).

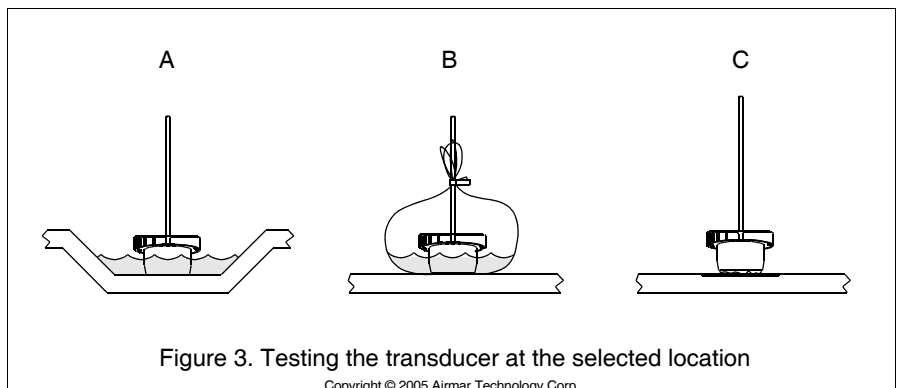
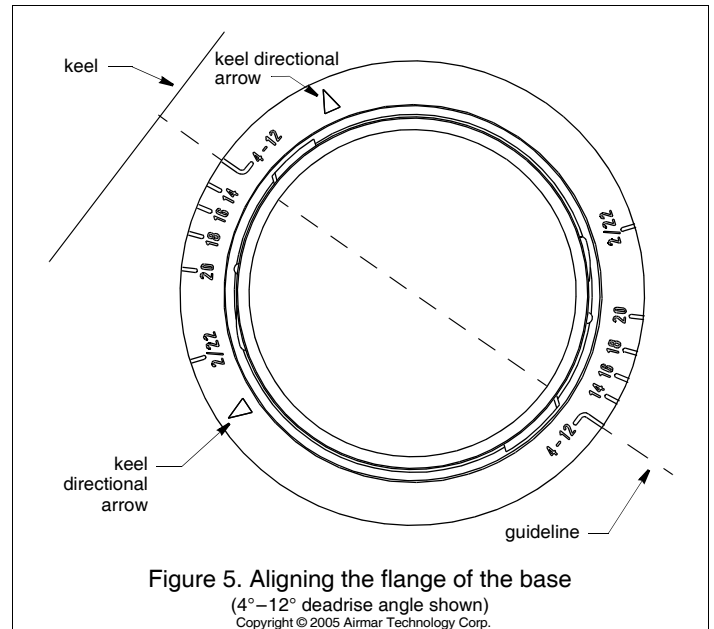
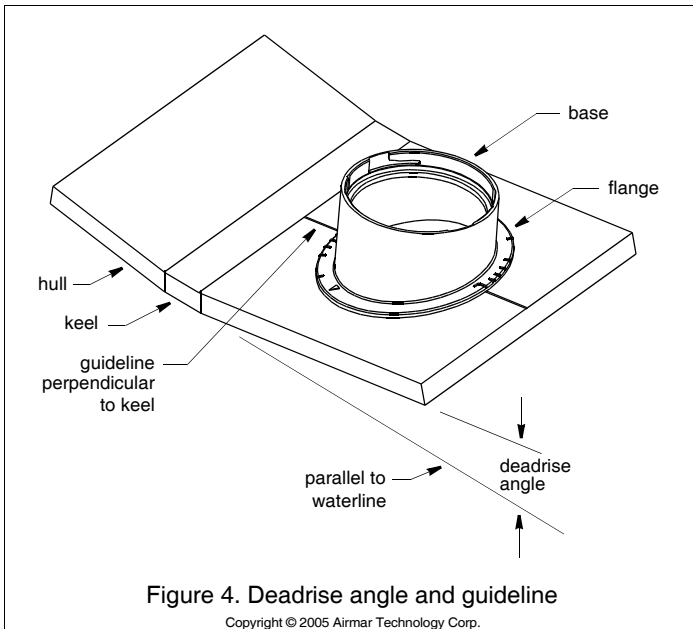

Figure 3. Testing the transducer at the selected location

Copyright © 2005 Airmar Technology Corp.



## Installation

**Cored fiberglass hull**—Follow separate instructions on page 4.

**CAUTION:** The base must be liquid-tight. To ensure a tight bond, the hull surface under and around the base must be smooth, free of paint or any other finish, clean, and dry.

**CAUTION:** The top of the transducer must be level when the installation is complete.

1. Measure the deadrise angle of the hull at the selected location using an angle finder (Figure 4). *Measure carefully, because the installed transducer must be within 5° of vertical.*
2. The hull surface to be bonded must be smooth and free of paint or any other finish. If the surface is rough, use a disk sander to smooth an area 100mm (4") in diameter.
3. To ensure a tight bond, clean and dry both the selected area and the underside of the base. Remove any dust, grease, or oil with detergent or a weak solvent such as alcohol.
4. Using a carpenter's square, draw a line on the hull perpendicular to the keel through the center of the mounting

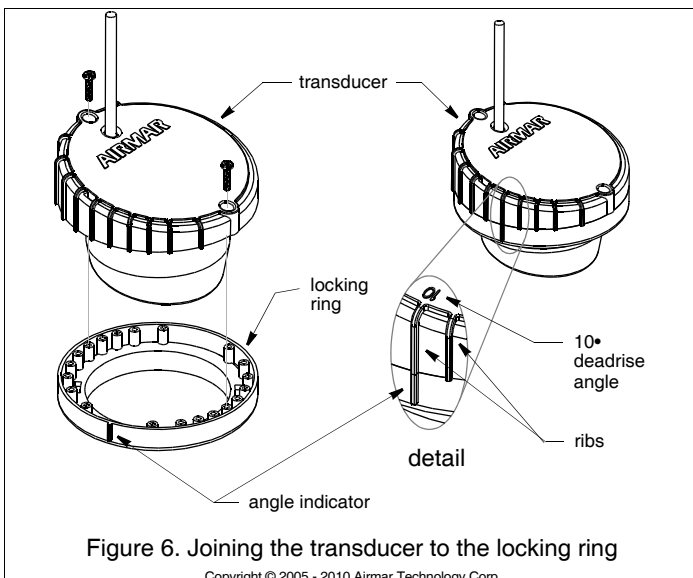

location (Figure 5). This will be used as a guideline to orient the base.

5. The numbers on the flange of the base represent deadrise angles. Identify the number that most closely corresponds to the deadrise angle of the hull. Find its match on the opposite side of the flange. *Keeping the keel directional arrows on the side of the base near the keel, align the two raised marks indicating the deadrise angle with the guideline drawn on the hull.*
6. When you are satisfied that the location of the transducer is optimal and the orientation of the base corresponds to the deadrise angle of the boat, apply a generous bead of silicone sealant to the underside of the flange of the base. (Follow the sealant manufacturer's instructions for its use.) Press the flange firmly in place to form a liquid-tight seal. Allow the sealant to cure.
7. Slide the transducer into the locking ring (Figure 6). Turn the transducer until the rib that most closely corresponds to the deadrise angle of the hull is aligned with the angle indicator on the locking ring. To secure the transducer to the locking ring, insert the two screws. **Do not over tighten the screws.**
8. Lubricate the O-ring with petroleum jelly. This will help to seal the assembly and prevent the fill-liquid from leaking. Slide the O-ring onto the transducer assembly (Figure 7).

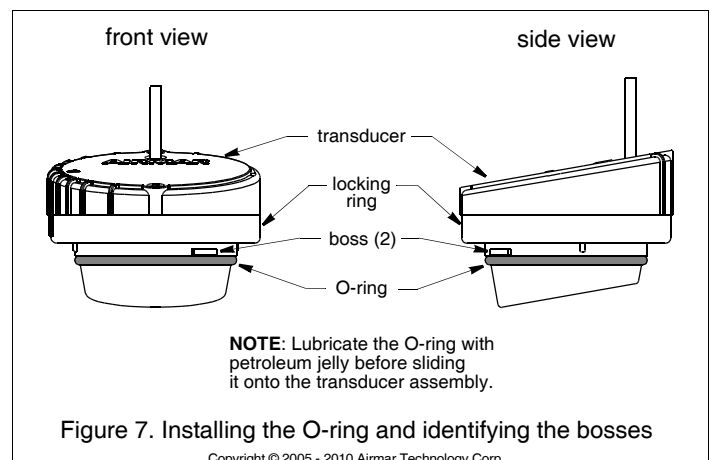

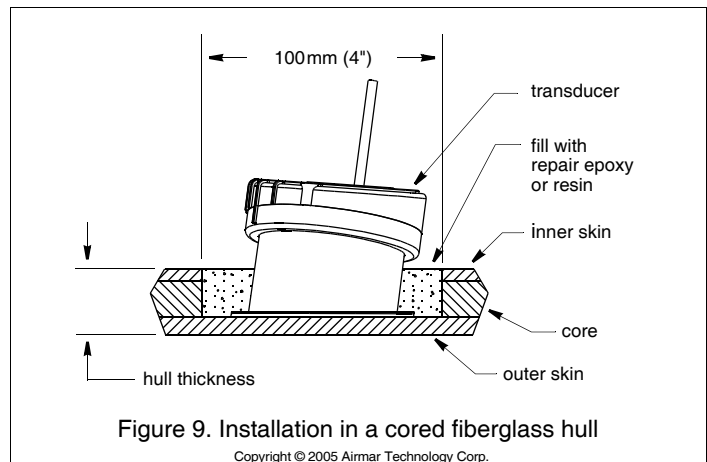
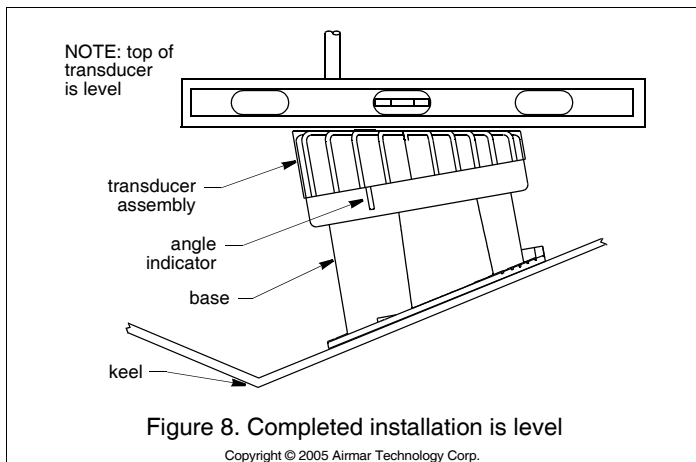

- After the sealant on the base has cured, pour 71 ml (2.4 fl. oz.) of propylene glycol into the base. Do not over fill. Be sure to follow the manufacturer's directions for use.
- With the angle indicator on the keel side, lock the transducer assembly into the base (Figure 8). (The bosses on the locking ring fit into the notches in the base.) Press down and rotate clockwise until it is seated. When the transducer is installed correctly, the top will be level. If the deadrise angle is shallow, the transducer may appear to be level even if it is not. Use a level to check the installation.

## Cable Routing & Connection

**CAUTION:** If the transducer came with a connector, do not remove it to ease cable routing. If the cable must be cut and spliced, use Airmar's splash-proof Junction Box No. 33-035 and follow the instructions supplied. Removing the water-proof connector or cutting the cable, except when using a water-tight junction box, will void the transducer warranty.

- Route the cable to the echosounder being careful not to tear the cable jacket when passing it through the bulkhead and other parts of the boat. Use grommets to prevent chafing. To reduce electrical interference, separate the transducer cable from other electrical wiring and sources of electrical noise. Coil any excess cable and secure it in place with cable ties to prevent damage.

**NOTE:** Some transducers are equipped with a short cable, about 1 m (3'), and an extension cable. **Be sure to locate the mated 3-pin connectors well above the bilge waterline.** To facilitate this, use one of the two cable clamps supplied on either side of the connection.

- Refer to the instrument owner's manual to connect the transducer to the instrument.



35 Meadowbrook Drive, Milford, New Hampshire 03055-4613, USA  
•www.airmar.com

## Installation in a Cored Fiberglass Hull

Installation in a cored hull is difficult. The objective is to bond the base to the **inside surface of the hull's outer skin** while preventing any moisture from penetrating the core.

**CAUTION:** There is no way to determine if the outer skin is solid (no trapped air bubbles in the fiberglass) at the selected location before cutting the inner skin.

- Using a 100mm or 4" hole saw, cut through the inner skin and the core at the selected location (Figure 9). The core material can be very soft. Apply only light pressure to the hole saw after cutting through the *inner* skin to avoid accidentally cutting the *outer* hull.
- Remove the plug of core material, so the inner core of the hull is fully exposed. Sand the *inside surface of the outer skin* using a miniature disk sander. Slightly undercut the surrounding coring if possible.
- Clean and dry both the *inside surface of the outer skin* and the transducer with a weak solvent, such as alcohol, to remove any dust, grease, or oil.
- Place the base in the cavity. Fill the gap between the base and the hull with repair epoxy or resin following the manufacturer's directions for its use.
- After the repair epoxy or resin has cured, proceed with "Installation" (page 3).

## Replacement Transducer & Parts

The information needed to order a replacement transducer is printed on the cable tag. Do not remove this tag. When ordering, specify the part number, date, and frequency in kHz. For convenient reference, record this information on the top of page one.

Lost, broken, or worn parts should be replaced immediately.

Base & O-ring Kit 33-268-01

Obtain parts from your instrument manufacturer or marine dealer.

Gemeco

USA

Tel: 803-693-0777

email: sales@gemeco.com

Airmar EMEA

Europe, Middle East, Africa

Tel: +33.(0)2.23.52.06.48

email: sales@airmar-emea.com