



# INSTALLATION INSTRUCTIONS

NMEA 2000® & NMEA 0183

## Splitter

for WeatherStation® Instrument  
GPS Receiver  
Heading Sensor

Patent <http://www.airmar.com/patent.html>



07/19/18

17-494-02 rev.04

**Follow the safety precautions below to reduce the risk of poor product performance, property damage, personal injury, and/or death.**

**WARNING:** Always wear safety glasses, a dust mask, and ear protection when installing.

**WARNING:** The power supply must be OFF before proceeding with the installation.

**WARNING:** A safe installation requires a 0.5 amp fast-blow fuse or circuit breaker. Except WeatherStation models with a heater require a 3 amp fast-blow fuse or circuit breaker.

**WARNING:** The power source must be isolated from the engine start battery(s). Voltage drops may cause the instrument/receiver/sensor to lose information and/or change operating mode.

**IMPORTANT:** Please read the instructions completely before proceeding with the installation. These instructions supersede any other instructions in your instrument manual if they differ.

## Applications

The Splitter allows the data from the instrument/receiver/sensor to be shown simultaneously on both an NMEA 0183 device and an NMEA 2000 networked instrument.

## Tools & Materials

Safety glasses  
Dust mask  
Ear protection  
Pencil  
Electric drill  
Drill bit: 3mm or 1/8"  
Grommets (some installations)  
Cutting pliers  
Phillips screwdrivers  
Wire strippers  
Heat-shrink tubing  
Heat gun  
Slip-joint pliers  
Adjustable wrench  
Multimeter

## Cable Routing & Connecting Guidelines

**CAUTION:** To reduce electrical interference from other electrical wiring and any on-board equipment with strong magnetic fields such as radar equipment, radio transmitters, engines, generators, etc., separate the cables by at least 1 m (3'). Ensure that all the cable shields are appropriately grounded.

**CAUTION:** Be careful not to tear the cable jackets when passing them through compartments, bulkheads, or walls. Use grommets to prevent chaffing.

**CAUTION:** Use a multimeter to check the polarity and the connections to the power supply before applying power to the instrument/receiver/sensor.

## Installation

### Mounting Location & Hole Drilling

1. Select a convenient dry location for the water-resistant Splitter, a minimum of 1 m (3') from other cables and electronic equipment.
2. Hold the Splitter at the selected location and mark the position of the four screw holes.

**NOTE:** If the Splitter will be mounted on a vertical surface, face the cordgrips downward to avoid any possibility of water seeping into the box.

3. At the marked locations, drill 3mm or 1/8" holes to a depth of 10mm (3/8"). Do not fasten the Splitter in place at this time.

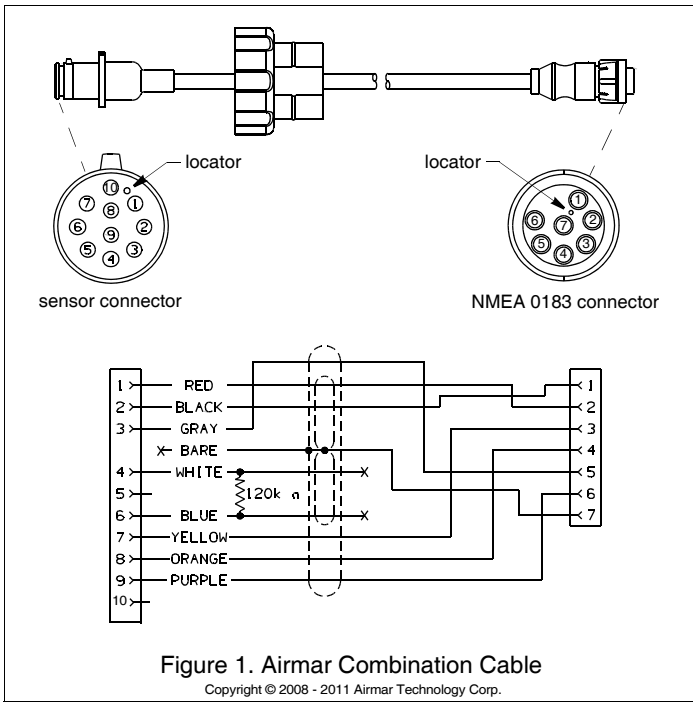

### Preparing the Cables

The Airmar Combination Cable is able to transmit data in both NMEA 2000 and NMEA 0183 formats. The cable can be cut into two parts (Figure 1). The section with the sensor connector becomes the sensor cable. The remaining section with the 7-pin, NMEA 0183 connector becomes the NMEA 0183 cable.

#### Sensor Cable

1. Route the Combination Cable from the instrument/receiver/sensor to the Splitter.
2. Allowing an extra 25cm (10") for wiring ease, cut the cable to length. (Set the remaining section of the cable aside. It will be used to connect the NMEA 0183 device to the Splitter.) *Do not connect the sensor cable or fasten it in place at this time*

#### NMEA 0183 Cable

The remaining section of the Combination Cable will become the NMEA 0183 cable.

1. Route this cable from the Airmar Data Converter, Airmar Combiner, or NMEA 0183 instrument to the Splitter.
2. Allowing an extra 25cm (10") for wiring ease, cut the cable to length. *Do not connect the cable or fasten it in place at this time.*

#### NMEA 2000 (Network) Cable (Figure 2)

1. Route the NMEA 2000 cable from the network node to the Splitter.
2. Allowing an extra 25 cm (10") for wiring ease, cut the cable to length. *Do not connect the cable or fasten it in place at this time.*

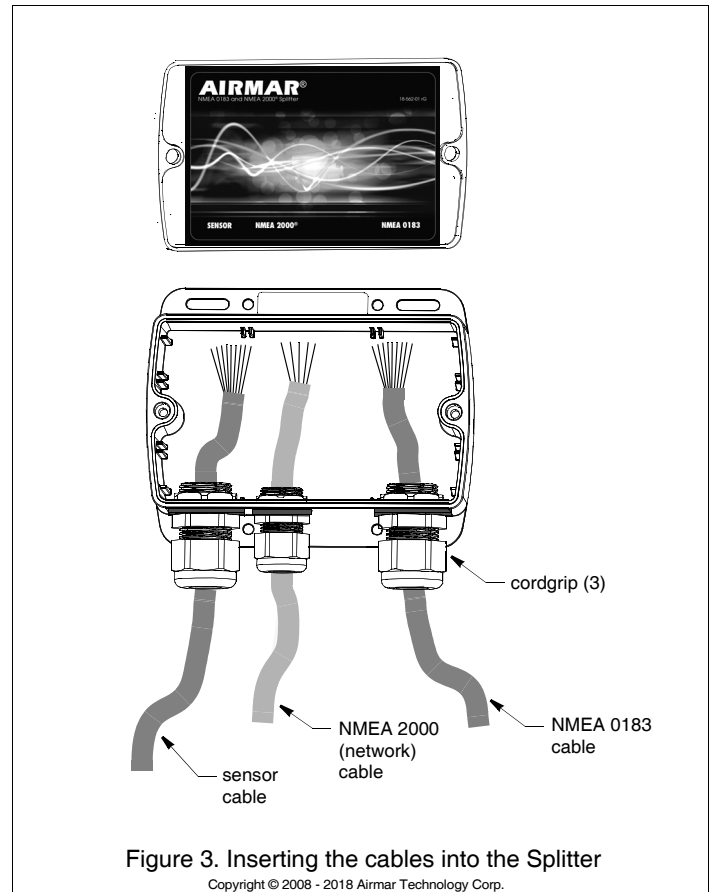
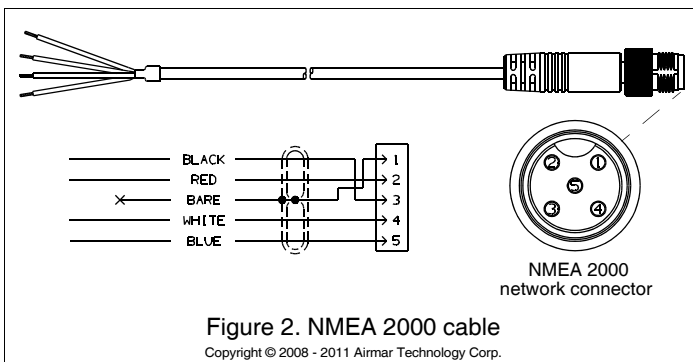

### Connecting

1. Remove the cover of the Splitter. Set it aside along with the two screws, the packet of silicone lubricant, and the bag of 6 x 1/2" screws and butt connectors.
2. Following the label on the Splitter cover, push approximately 200mm (8") of each cable through the appropriate cordgrip (Figure 3).
3. Strip 60mm (2-1/2") of the outer jacket and foil shielding from the cut end of each cable (Figure 4).
4. **NMEA 0183 Cable Only** (Figure 5)
  - Cut off the white and blue wires flush with the cable jacket.
  - *The black wire and the red wire will NOT be connected.* Cover the end of each wire with heat-shrink tubing to prevent the possibility of a short circuit inside the Splitter. Use a heat gun to shrink the tubing.

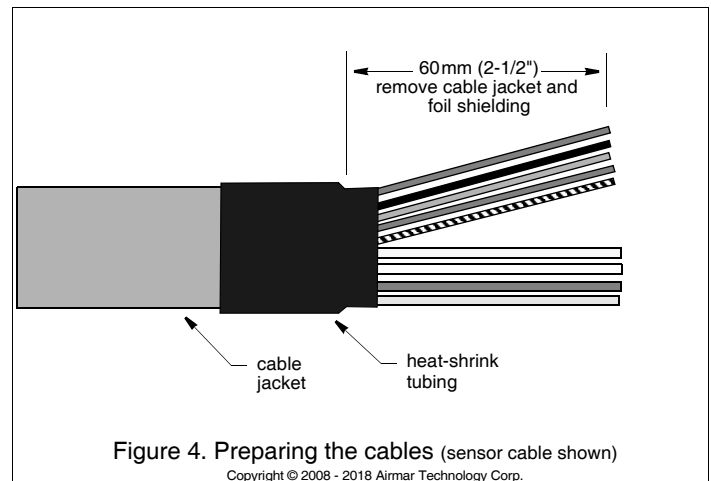

**NOTE:** Insert the end of a colored wire into one of the holes in a butt connector. Insert the *matching* colored wire from another cable into the opposite hole. With the wires pushed tightly against the far inside wall of the connector, squeeze the red button until it depresses.

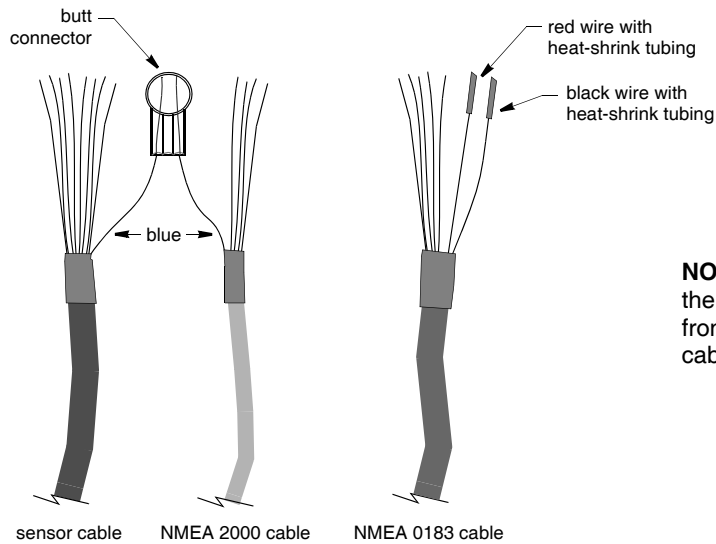

**NOTE:** Do *not* connect the red and black wires from the NMEA 0183 cable.

Figure 5. Using the butt connectors  
Copyright © 2008 - 2009 Airmar Technology Corp.

5. Protect each cable's foil shielding from causing a short circuit inside the Splitter (Figure 4). Use heat-shrink tubing around the jackets where the wires emerge from the cable. The tubing must overlap the wires a minimum of 6mm (1/4"). Use a heat gun to shrink the tubing.

**NOTE:** One of the butt connectors will be used to connect the three bare wires. (Each connector has 3 holes to accommodate up to 3 wires.)

6. Make the connections using the red butt connectors supplied. Insert the end of a colored wire into one of the holes in a butt connector (Figure 5). Insert the *matching colored wire* from another cable into the opposite hole. (It is not necessary to remove the colored insulation.) With the wires pushed tightly against the far inside wall of the connector, squeeze the red button until it depresses using slip-joint pliers. Gently tug on each wire to ensure that it is securely fastened. Repeat this process until all the wires are connected as shown in the wiring diagram (Figure 6).

**NOTE:** The red wire from the sensor cable will be connected to the red wire from the NMEA 2000 cable. Likewise, the black wire from the sensor cable will be connected to the black wire from the NMEA 2000 cable. Do **NOT** connect the red and black wires from the NMEA 0183 cable.

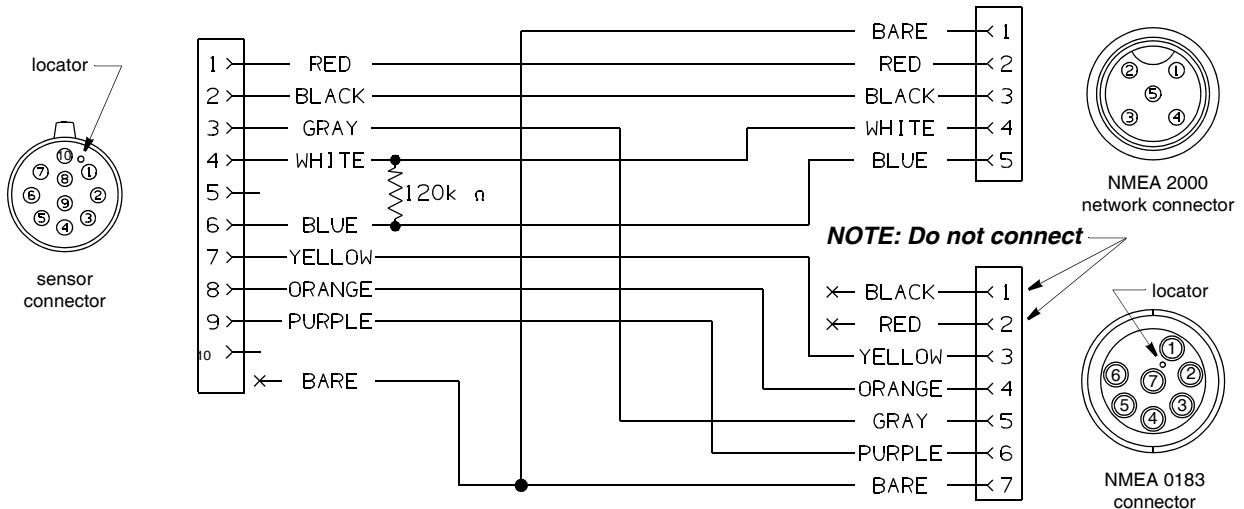

Figure 6. Wiring diagram  
Copyright © 2008 - 2011 Airmar Technology Corp.

### Completing the Installation

1. From outside the Splitter, pull each cable until only 25mm (1") of jacket remains inside the box. Hand tighten the cordgrips. To make a watertight seal, use an adjustable wrench to tighten each cordgrip an additional 1/4 to 1/2 turn (Figure 3).
2. Arrange the wires neatly inside the Splitter. Check to be sure the gasket is firmly installed in the channel on the back side of the cover (Figure 7). Lubricate the gasket with the silicone lubricant supplied. Screw the cover in place with the two long screws supplied.
3. Fasten the Splitter in place with the four 6 x 1/2" screws supplied in the plastic bag.
4. Plug the sensor cable's connector into the sensor.
5. Plug the NMEA 2000 cable's connector into the network.
6. Plug the NMEA 0183 cable's connector into the Airmar Data Converter or Airmar Combiner.

#### Connecting to an NMEA 0183 instrument

- Cut off the connector and discard.
  - The white, blue, red, black, and bare wires are not needed. Cut them off flush with the cable jacket.
  - Protect the cable's foil shielding from causing a short circuit by covering the cable jacket with heat-shrink tubing where the wires emerge from the cable. The tubing must overlap the wires a minimum of 6mm (1/4"). Use a heat gun to shrink the tubing.
  - Connect the following wires:

grey	A/+ NMEA output
purple	B/- NMEA output
yellow	A/+ NMEA input
orange	B/- NMEA input
7. Fasten all the cables in place.

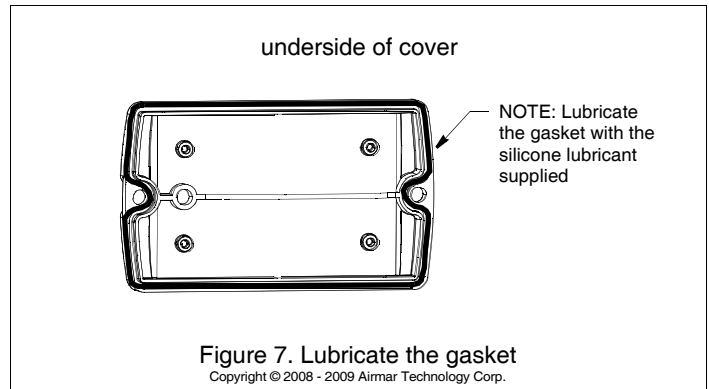

### Parts

Obtain parts from your sensor manufacturer or marine dealer.

#### Gemeco

#### USA

Tel: 803-693-0777

email: sales@gemeco.com

#### Airmar EMEA

#### Europe, Middle East, Africa

Tel: +33.(0)2.23.52.06.48

email: sales@airmar-emea.com

NMEA 2000® is a registered trademark of the National Marine Electronics Association.



35 Meadowbrook Drive, Milford, New Hampshire 03055-4613, USA  
•www.airmar.com