



10.4 INCH LCD COLOR ECHO SOUNDER

ES-2035 II

OPERATION MANUAL

SUZUKI FISH FINDER CO., LTD.

12-1 MAMIZUKA, TOYOHASHI
AICHI 441-8007, JAPAN

PHONE: (81) 532-32-7511 FAX: (81) 532-32-7500
<http://www.suzukiff.co.jp/> sales@suzukiff.co.jp

CONTENTS

Chapter 1	2
INTRODUCTION	
BEFORE OPERATION	3
FOR YOUR SAFETY	5
SUPPLIED COMPONENTS	7
INSTALLATION	8
CONTROL PANEL	17
MODE EXAMPLE	18
Chapter 2	19
FUNCTION SETTINGS	
INITIAL SETTINGS	20
MENU	22
Chapter 3	35
OPERATION of DIALS and KEYS	
KEY OPERATION	36
DIAL OPERATION	46
Chapter 4	48
APPENDIX	
WHAT IS AN ECHO SOUNDER?	49
CLEANING & DISPOSAL	53
SPECIFICATIONS	54

Chapter 1

INTRODUCTION

Thank you for purchasing the ES-2035II.

This operation manual provides complete information on safely operating **the COLOR LCD ECHO SOUNDER MODEL ES-2035II** to its full potential.

Before operating this equipment, please read this manual thoroughly to understand the operation to avoid any trouble and possible injury in advance.

BEFORE OPERATION	SYMBOLS	3
	CAUTION NOTE	3
	POWER ON/OFF	4
	KEY OPERATION	4
FOR YOUR SAFETY	ENVIRONMENTAL	5
	CONDITIONS	
	CONVENIENT LOCATION	5
	POWER REQUIREMENTS	6
	HANDLING	6
SUPPLIED COMPONENTS	COMPOSITION	7
INSTALLATION	DIMENSIONS	8
	MAIN UNIT MOUNTING	9
	TRANSDUCER INSTALLATION	10
	CONNECTIONS to REAR PANEL	15
	ELECTRICAL CONNECTIONS	16
CONTROL PANEL MODE EXAMPLE	CONTROL PANEL	17
	DISPLAY	18

BEFORE OPERATION

SYMBOLS

The following conventions are used in this manual.

Before using this unit, make sure to understand the following, which are used throughout this manual.



: indicates and imminently hazardous situation which, if not avoided, will result in death or serious injury.



: indicates a potentially hazardous situation which, if not avoided, will result in death or serious injury.



: indicates precautionary measures to avoid potential problems.

NOTE !

: indicates contents for the user's reference.

cf

: see the page.

CAUTION NOTE

This manual contains important information about the ES-2035II.

In order to fully understand the operation, and know detailed information for your safety, please read this manual carefully.

Keep this operation manual in a safe place where it is easy to find.



When you give this unit to someone else, make sure to give this manual, too.

Any use other than that mentioned in this manual is not guaranteed.

The contents in this manual are subject to change without notice or obligation.

Please contact us if you should have any questions regarding the use of this equipment.

POWER ON/OFF

Press and hold the  key to turn on the power. After one beep the echo sounder display appears on the screen. Hold the  key to turn the power off.

KEY OPERATION

One beep will advise you when a right function is performed.

Three beeps will advise you when a wrong operation or a wrong key is pressed.

ENVIRONMENTAL CONDITIONS



Keep the unit away from flammable gas.
It will cause fire.



Pay attention to the following environmental conditions on mounting, otherwise the unit may become heated causing trouble and malfunction.

- It is recommended that it will be mounted in a location which provides protection from spray or heavy vibration.
 - Do not bring any other heated object close to the equipment,
 - Do not bring any magnetic object close to the equipment.
-

CONVENIENT LOCATION



Find a convenient location. The ES-2035II may be mounted upright on any level surface and tighten securely.

Make sure the following on wiring. Otherwise damage or fire may occur.

- Take care of connecting the cables not to be disturbed the operation.
 - Do not use the cables bent, twisted or stretched by force.
 - Do not put heavy objects on the cables.
-



When removing/plugging in cables, make sure to turn the power off.
Never pull cables, otherwise it may damage the unit and result in fire or electrical shock.

POWER REQUIREMENTS



Operating voltage: 10.5 to 30 volts DC

Please use correct voltage, otherwise, it will lead to fire or electric shock, or damage to the unit.



Make sure to turn off the power by the power "ON/OFF" keys on the control panel. Turning on/off the power by the ships switchboard may damage the unit or cause problems with operations. When starting the vessels engine, make sure the power of this unit is turned off, otherwise it may cause problems with the unit.

HANDLING



Do not operate this unit while steering.

It could result in collision and serious injury or damage.

Do not open the main unit case. Otherwise electrical shock, damage, and serious bodily injury to user may result. For inspection/adjustment/parts installation/repair, please ask your dealer. There is a high voltage component inside, and it will result in electric shock.

The sufficient reinforcement and water tightness should be make when installing the transducer.

It could result in collision and serious injury or damage.



Please use the specified fuse.

If not, it could result in malfunction and / or fire.

Please use the specified power supply cable cords.

Using cables other than those specified could generate heat an

When replacing batteries,



- Insert new batteries. Be sure that the polarity (+ , -) is correct.
- Never subject batteries to very hot or cold temperatures, or
- disassemble or dump into fire/water.
- Never use batteries with fluid leaking out.

SUPPLIED COMPONENTS

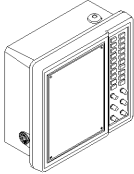
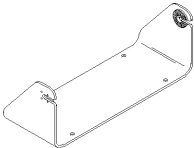
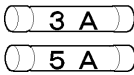
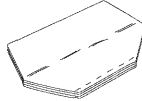
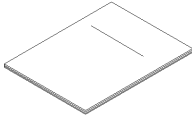

COMPOSITION

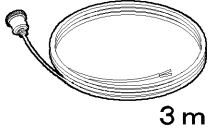
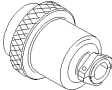
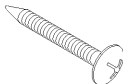
CODE		**RN110	**RN121		
	MAIN UNIT	BRACKET	POWER FUSE	UNIT COVER	O. MANUAL
ITEM					
PARTS#	—	35275C	—	2035-COV	2035II-OPM-E
QTY	1	1	EACH 3	1	1

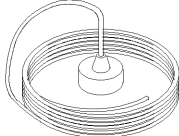
[A] ACCESSORIES FOR SINGLE FREQUENCY UNIT, ES-2035II (1F)

CODE	**RN010				
	POWER SUPPLY CABLE	TD PLUG	TAPPING SCREW	HEX.BOLT	TRANSDUCER ETC.
ITEM	 3 m				
PARTS#	33282D	HS21P-3	M 6 x 20	M 8 x 20 with washer	TD related parts
QTY	1	1	4	2	when required

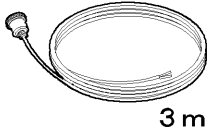
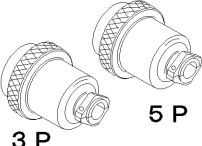
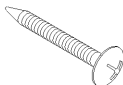
[B] ACCESSORIES FOR DUAL FREQUENCY UNIT, ES-2035II (2F)

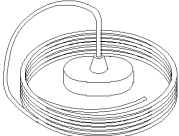
CODE	**RN020				
	POWER SUPPLY CABLE	TD PLUG	TAPPING SCREW	HEX.BOLT	TRANSDUCER ETC.
ITEM	 3 m	 3 P 5 P			
PARTS#	33282D	HS21P-3 / P-5	M 6 x 20	M 8 x 20 with washer	TD related parts
QTY	1	EACH 1	4	2	when required

NOTE 1) : Either [A] or [B] is supplied to the unit.

NOTE 2) : The code number is shown on the packages. However ** indicates the lot management number.

INSTALLATION

DIMENSIONS

DUAL FREQUENCY UNIT

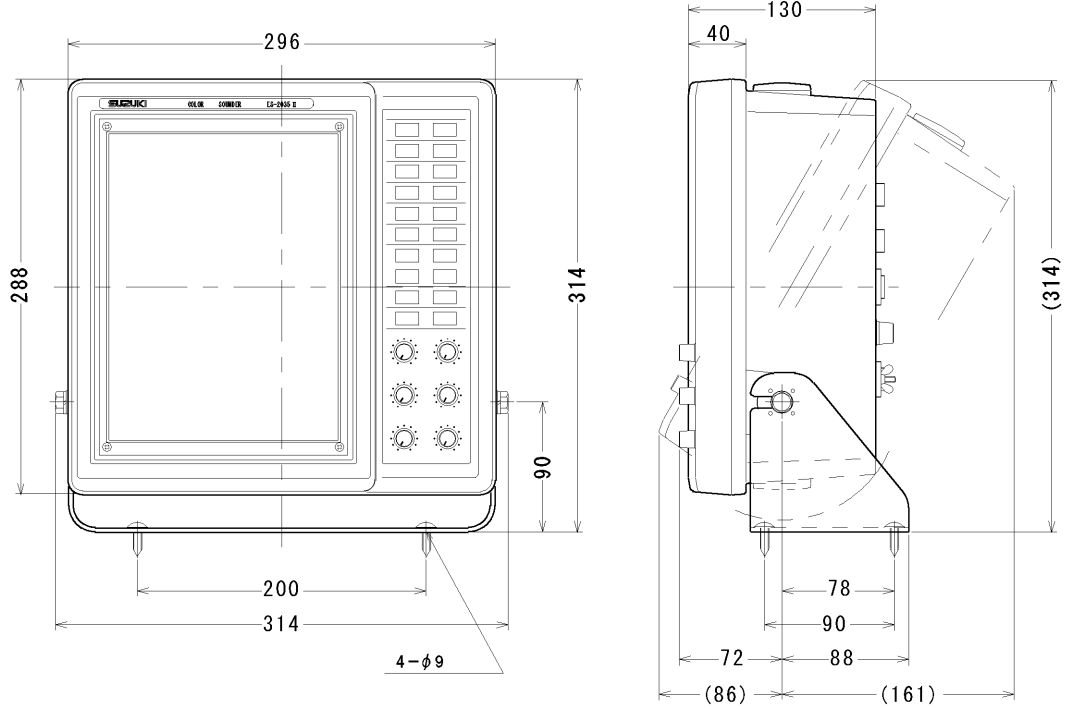

SINGLE FREQUENCY UNIT

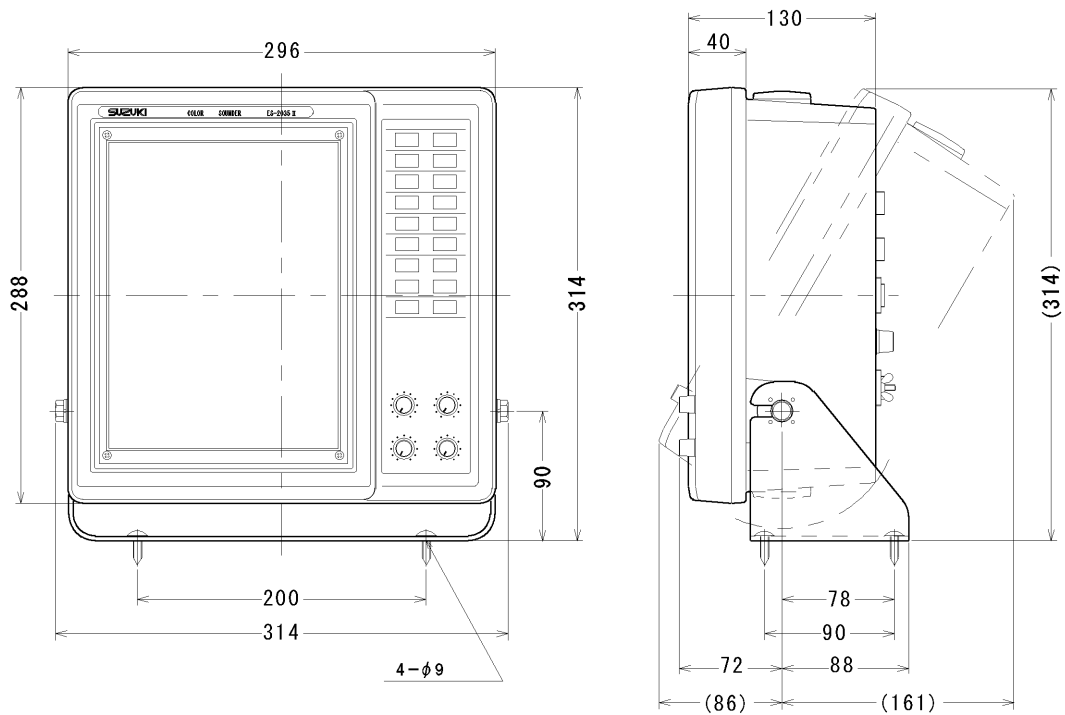

MAIN UNIT MOUNTING

- 1) Using the attached tapping screws (4 pcs), secure the mounting bracket to the site selected.
- 2) Screw the hexagonal bolts (M8 x 20 with washer) temporarily to the notches of the mounting bracket.
- 3) Insert the main unit and select a comfortable viewing angle.
Tighten the hexagonal bolts.



The unit should be installed on a flat surface.
Do not use the unit while tentatively installed, otherwise it may cause trouble

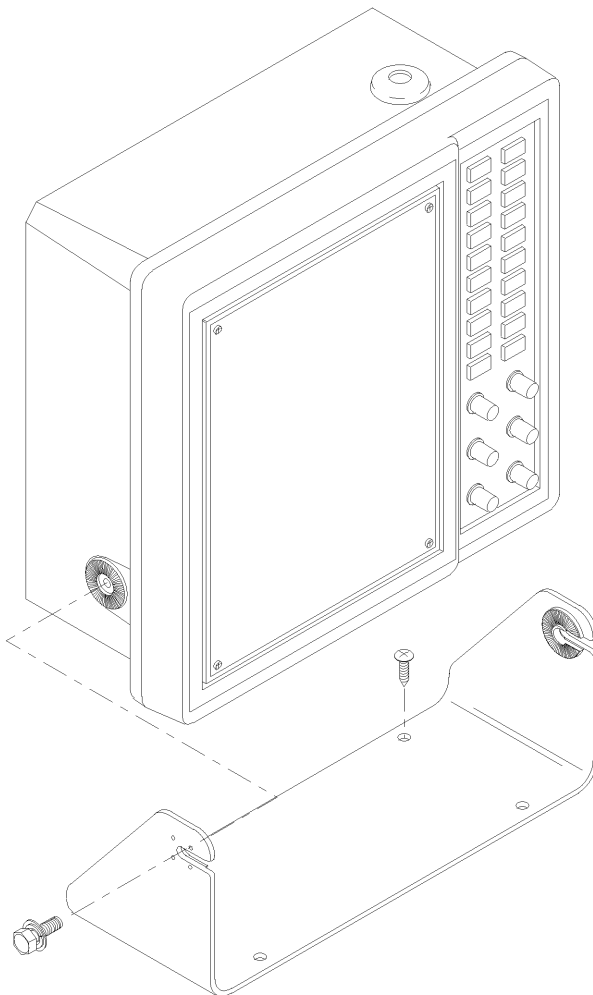

For long term trouble-free service, the proposed site for installation should be free as much as possible from shocks and engine vibrations and away from salt spray, heat sources and direct sunlight.

TRANSDUCER INSTALLATION

1. INSTRUCTIONS

Since the transducer is like an antenna for a radio and is a vital element for Echo sounder, it should be installed with the greatest care for optimum performance.

1) BEWARE OF BUBBLES

The transducer transmits a sound wave and receives an echo. When passing over the transducer face (see picture 1-1), bubbles reflect the sound wave and appear as echoes on the screen (see picture 1-2). Air bubbles and turbulence caused by the vessel's movement through the water will seriously degrade the transducer's performance. Therefore the transducer should be located well clear of any water intake or discharge line and also clear of any projection along the hull line which might disturb the smooth flow of water.

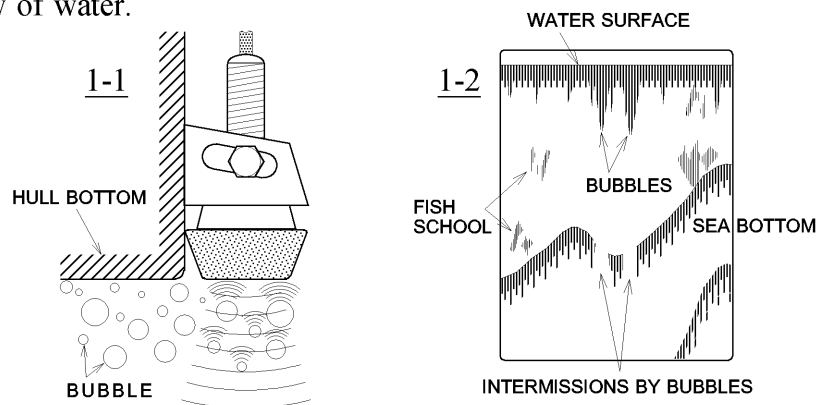

2) BEWARE OF NOISE

Install the transducer and its cable as far from the engine and the screw propeller as possible to avoid noise. The transducer cable should be run as far as possible from other electrical cabling.

3) BEWARE OF SHOCK

Do not drop or jolt the transducer as it may cause a damage or malfunction.

4) BEWARE OF INSTALLATION DEPTH

The transducer mounting face may be angled slight forward on the order of 3 degrees and be always immersed in the water as deep as possible and is parallel to the water surface.

5) MAINTENANCE

Periodically clean the face of the transducer for good performance. Do not use a harsh abrasive or a solvent to clean the transducer.

2. THROUGH-HULL INSTALLATION

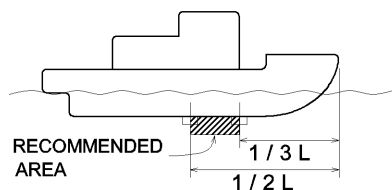

This is the way to install the transducer through a hole in the hull bottom. The appropriate installation depends on the type of vessel such as wooden, FRP, steel etc.

Please install the transducer in accordance with the following conditions.

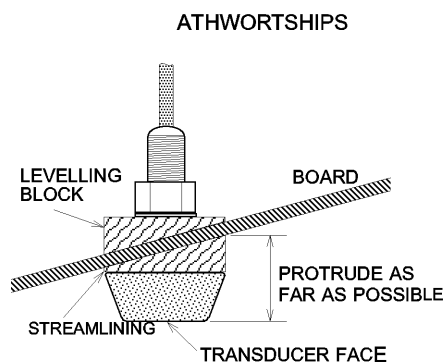

To be installed somewhere between $1/3$ and $1/2$ of the vessel's water line length from the bow and 30 cm away from the keel.

Tighten the levelling block (fairing block) to meet the requirement that the transducer mounting face can be angled slight forward on the order of 3 degrees and paralleled to the water surface.

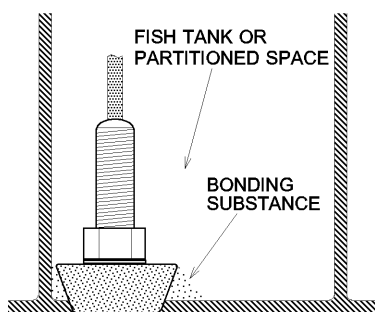

Through Hull Installation can be also applied inside the fish tank or a partitioned space as the picture left.

It should be noted that the more the transducer protrudes from the hull, the better the results will be. However, in case of a high speed boat, the transducer should protrude as little as possible to reduce drag and excessive force.



Care must be taken to ensure that the stuffing tube and the mounting bolts may be watertight. Careful consideration must be given not to be damaged when the transducer protrudes from the hull bottom.

3. HULL-SIDE INSTALLATION

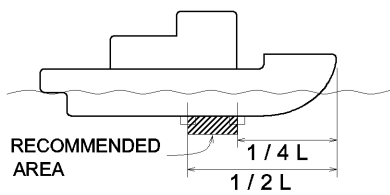

This is the way to install the transducer with a pipe to the port or starboard of the hull.

This way is suitable comparatively for the small vessel.

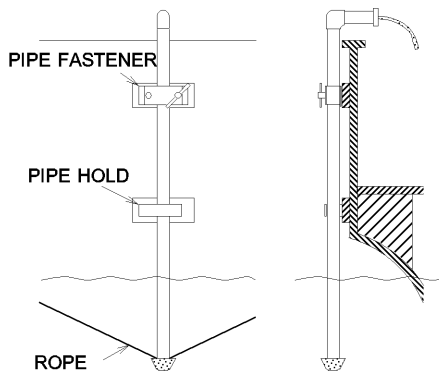

Please install the transducer in accordance with the following conditions.

To be installed somewhere 1/4 of the vessel's water line length from the bow.

Transducer should be protruded between 1m and 1.5m from the draft.

Install the pipe in order to make the transducer face paralleled to the sea surface or transducer working face is inclined towards the fore within 3 degrees.

The pipe should be tightly installed so that the pipe does not vibrate while the vessel is running.

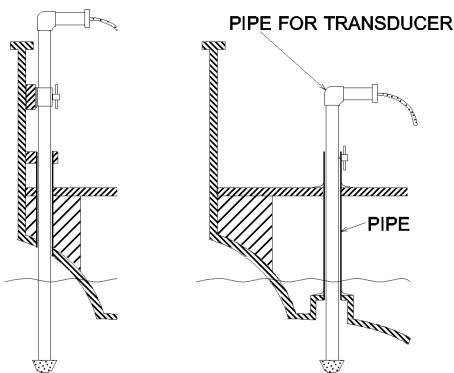

DOUBLE PIPE METHOD

Pass the thin and strong rope to the portion, where the transducer and the pipe are jointed, and stretch it toward the bow and the stern.

It is possible to install the pipe double as the picture left.

The pipe can be easily mounted (or dismantled) to the hull side with the metal fitting or sucking disk, and this method allows stable performance avoiding bubbles to the transducer.

However, as the pipe is an obstacle during ship's navigation and fishing operation it can be dismantled from the hull side when the sounder is not in use.



Air bubbles and noise will seriously degrade the performance, so care must be taken not to incline the transducer radiating surface up the stern.

4. TRANSOM INSTALLATION

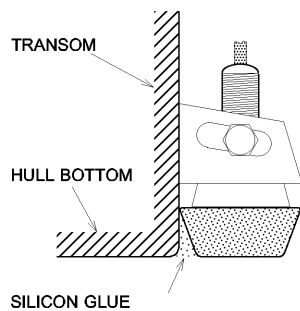

This is the way to install the transducer at the stern.

Fit the transducer to the metal fitting and fix it with the screws so that the transducer face is in alignment with the hull bottom. Install the transducer face horizontally. Cover the screw with sealant.

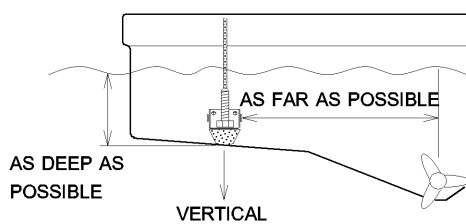

Use the metal fitting bolt to adjust the transducer face to be in alignment with the hull bottom.

Any gaps between the hull bottom and the transducer should be filled up with silicone type glue and the entire surface should be made as smooth as possible to provide an undisturbed flow of water over the transducer face.

5. HOUSING BOX INSTALLATION

a) IN-HULL KIT (OPTION)

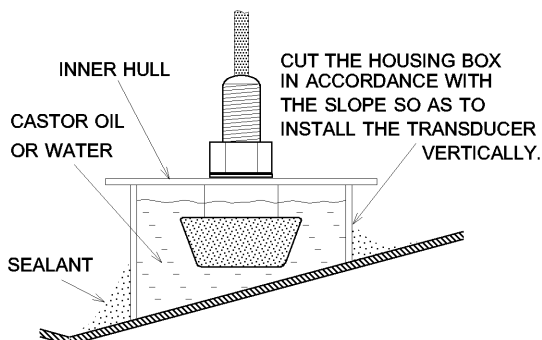

This is the way to install the transducer in the bottom board using an optional in-hull kit.

Fix the housing box on the bottom board and pour in ample water or castor oil so as the transducer face is not left exposed.

This way can easily be done without professional skills nor damaging the hull body. For further details, refer to optional in-hull kit manual.



This method using water can not be recommended in the area where the water is frozen.

b) INSTALLATION TO THE BOTTOM BOARD

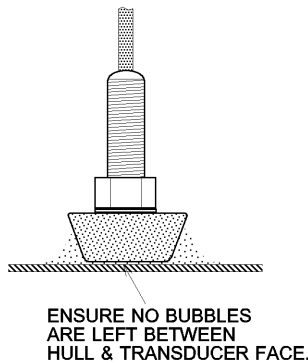

This is the way to install the transducer directly to the bottom board.

Grind the place where the transducer is installed to remove oil.

Fix the transducer face directly to the bottom board with glue. Stick carefully so as not to remain bubbles between the transducer face and the bottom board.

c) INSIDE TANK INSTALLATION

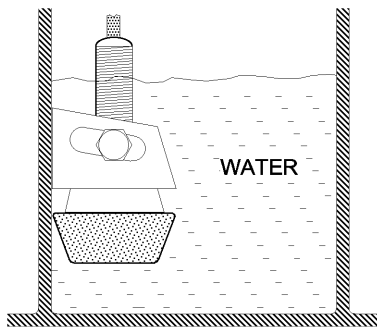

This is the way to install the transducer using a fish tank.

Before fixing the transducer inside the tank, fill the tank with water and find out the best recording position by holding the transducer by hand.



The housing box installation is applicable to FRP (single ply) or aluminum hull boats only.

Install the transducer where the FRP thickness is below 10 mm, and avoid the keel and ballast fin vicinity.

As the sound waves are transmitted through the hull board, the sensitivity will be inferior to those external installation way, and also the thicker the hull board the less the sensitivity.

CONNECTIONS to REAR PANEL

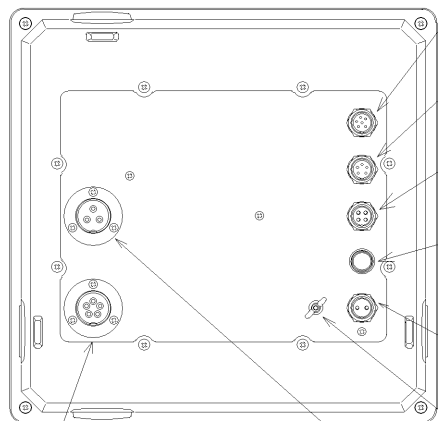

NMEA-0183 DATA OUTPUT

NMEA-0183 data (depth and water temp.) output to external equipment.

NAVIGATOR INTERFACE

NMEA-0183 data input or to be connected to a navigator.

TEMPERATURE SENSOR SIGNAL INPUT

To be connected to an optional temperature sensor OP-102 or OP-41.

FUSE HOLDER

Use the correctly-rated fuse specified below.

<u>POWER SUPPLY</u>	<u>FUSE RATING</u>
12V.....	5A
24V.....	3A
32V.....	3A

POWER SUPPLY TERMINAL

The power supply voltage range from 10.5 to 30 volts DC.

EARTH TERMINAL

To be connected to a GND point.

3 PIN TRANSDUCER TERMINAL

To be connected to the single frequency TD (50 or 200kHz).
To be connected to the high frequency TD (200kHz) when two TDs are used.

5 PIN TRANSDUCER TERMINAL

To be connected to the dual frequency (50/200kHz)
To be connected to the low frequency TD (50kHz) when two TDs are used.
In case of the model ES-2035II(1F) this terminal is not equipped.

ELECTRICAL CONNECTIONS

WATER TEMP.SENSOR (4 pins)

PIN No.	CONNECTION
No. 1	WHITE
No. 2	SHIELD
No. 3	NC
No. 4	BLACK

NAVIGATOR -INTERFACE (5 pins)

PIN No.	CONNECTION
No. 1	SIGNAL INPUT+
No. 2	SIGNAL INPUT-
No. 3	SHIELD
No. 4	SIGNAL OUTPUT+
No. 5	SIGNAL OUTPUT-

NMEA -INTERFACE (6 pins)

PIN No.	CONNECTION
No. 1	NC
No. 2	NC
No. 3	SHIELD
No. 4	SIGNAL OUTPUT+
No. 5	SIGNAL OUTPUT-
No. 6	NC

3 PIN PLUG for TRANSDUCER

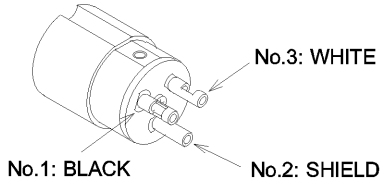

The two leads (No.1 and No.3) may be reversed without affecting the transducer performance.
(No.1: white No.3: black)

In some cases, the colors of the leads differ according to the type of transducer. Solder the cable's leads and shield to the three pins on the plug body.

2 PIN PLUG for POWER SUPPLY CONNECTION

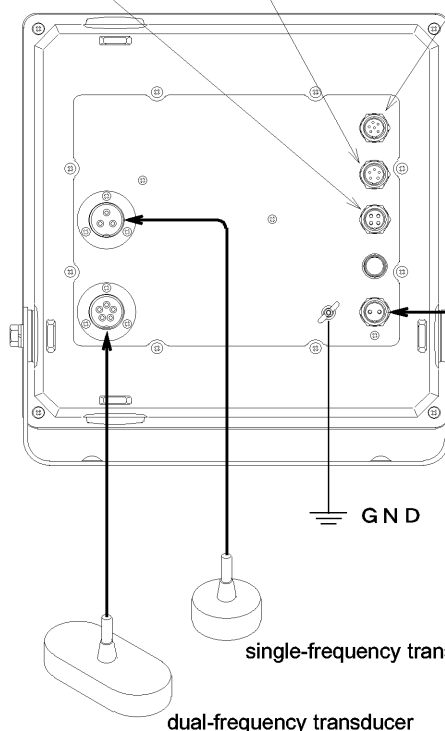
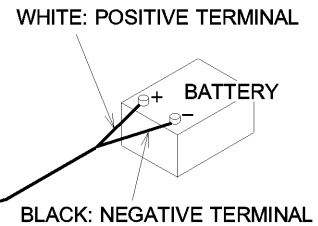
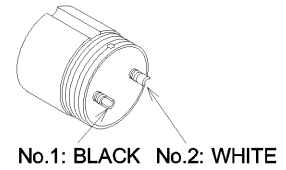

TWO-FREQUENCY TRANSDUCER
5 PIN PLUG for TRANSDUCER

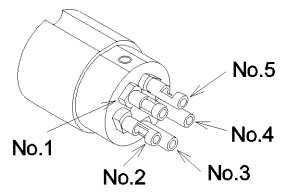

The two leads (No.1 and No.2 or No.4 and No.5) may be reversed without affecting the transducer performance.

5 PIN PLUG CONNECTIONS for DUAL FREQUENCY TRANSDUCERS

PIN	50/200kHz TD	50/200kHz SEPARATE TD	
No.1	GREEN	200kHz	
No.2	RED		
No.3	SHIELD	SHIELD	
No.4	BLACK	BLACK	50kHz
No.5	WHITE	WHITE	



Power requirement: DC10.5 - 30V. Using any power voltage other than the indicated voltage can cause it to lead to fires or electric shocks.

Use the indicated power supplied cables.
Using any power supplied cable other than the indicated cable can cause it to lead to fires.
The ES-2035II must be turned off while connecting/disconnecting the cables.
Otherwise the cables may be damaged and result in fires or electric shocks.

Do not use the cables bent, twisted or stretched by force.
Do not put heavy objects on the cables. Otherwise the cables may be damaged and result in fires or electric shocks.

CONTROL PANEL

CONTROL PANEL

The main functions of the ES-2035II sounder is all controlled by means of the dials and keys. The following is a description of the function of the main controls in case of a dual frequency unit, ES-2035II (2F).

POWER SUPPLY KEYS :

Turns on the power or turn the power off.

cf PAGE 4

MENU KEY :

Calls up the menu display.

cf PAGE 22

VRM KEYS :

Enters a vertical marker in the display. **cf** PAGE 37

ALARM KEYS :

Access the alarm range settings. **cf** PAGE 38

THRESHOLD KEY :

Eliminates the weak target colors from the display.

cf PAGE 40

MODE SELECTION KEY :

Selects the display mode.

cf PAGE 42

! This function is not available on the single frequency unit, ES-2035II (1F).

STC CONTROL DIALS :

Suppresses unnecessary echoes near the water surface.

cf PAGE 46

! One dial on the ES-2035II (1F).

NOISE SUPPRESSION DIAL :

Activates the noise rejection function. **cf** PAGE 46

ALARM ENTRY KEY :

Confirms entry of the alarm range settings and also turns this function mode on or off.

cf PAGE 40

RANGE KEYS :

Selects the basic range. **cf** PAGE 36

PHASED RANGE KEYS :

Adjusts the scale/range of depth between available values.

cf PAGE 36

EXPANSION RANGE KEYS :

Selects the expansion range for the bottom expansion mode.

cf PAGE 37

PICTURE SPEED KEY :

Selects the rate of picture movement. **cf** PAGE 41

INTERFERENCE

REDUCTION KEY :

Reduces interference from nearby fishing vessels. **cf** PAGE 44

! In case of the ES-2035II (1F) this function can not be activated by means of this key, but via MENU display.

GAIN CONTROL DIALS :

Adjusts presentation of received echo.

! One dial on the ES-2035II (1F).

cf PAGE 47

BRIGHTNESS CONTROL DIALS :

Adjusts the display brightness.

cf PAGE 47

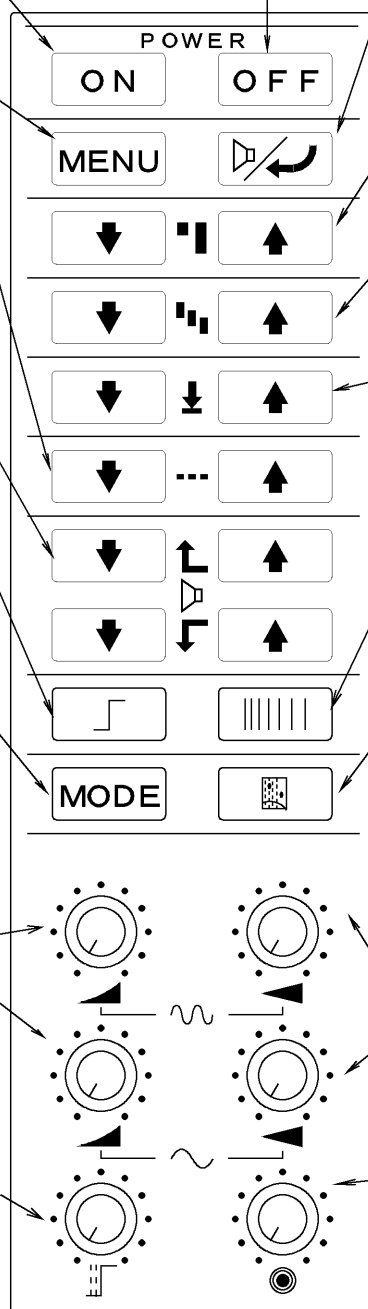

MODE EXAMPLE

DISPLAY

The below shows an example for dual frequency and normal display modes.
Bottom expansion mode is different from this display.

! In case of a single frequency unit, ES-2035II (1F)

Either Single frequency mode or Bottom expansion mode is available.

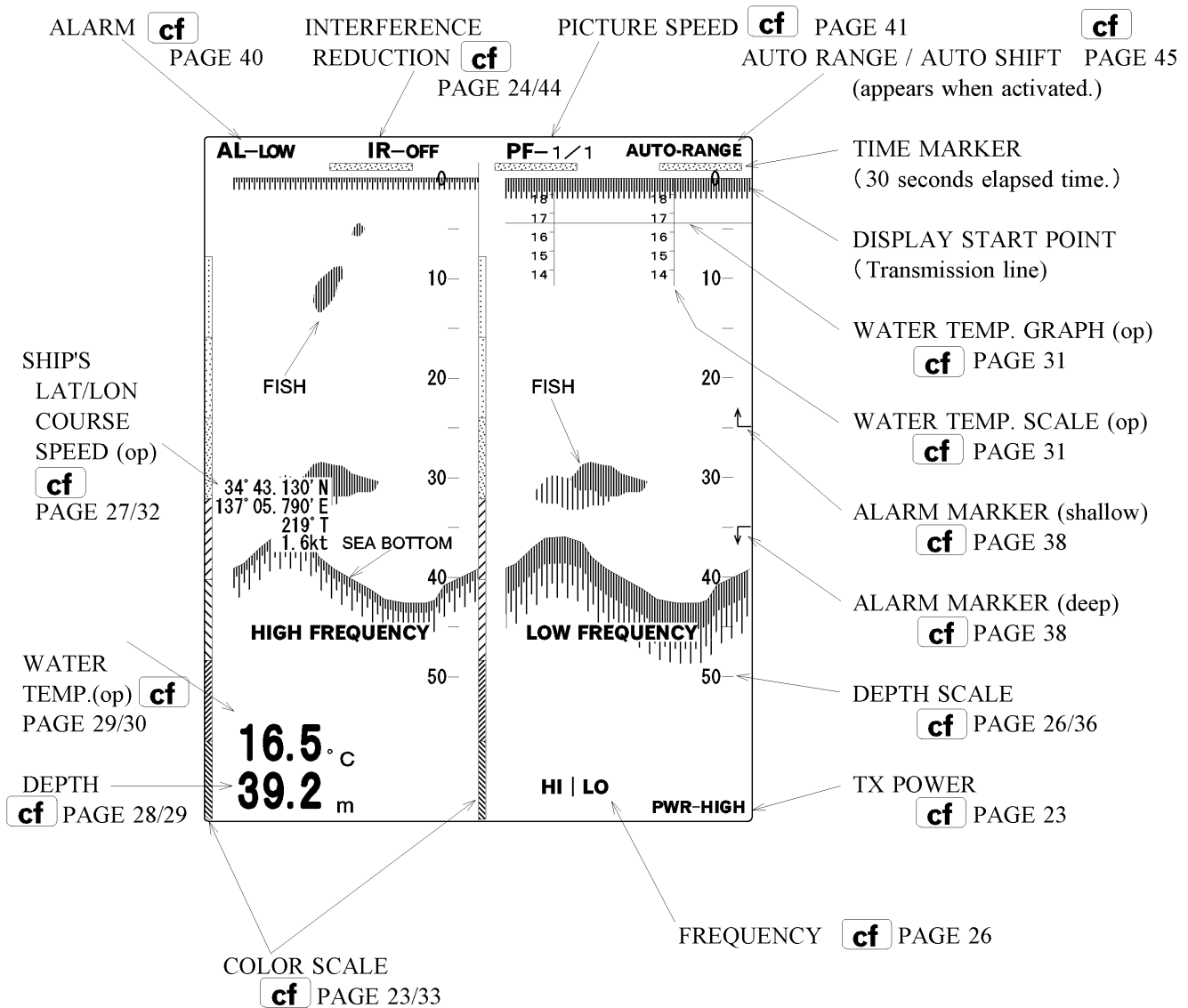

NOTE : (op) indicates an optional equipment required.

FUNCTION SETTINGS

This chapter provides you the explanation for function settings.
Please set each function before using the ES-2035II to suit individual needs.

INITIAL SETTINGS	FACTORY SETTINGS	20
	RETURN TO FACTORY SETTINGS	20
	(INITIAL SETTINGS)	
	USER SETTINGS	21
MENU		22
	D RANGE	23
	TX POWER	23
	INTERFERENCE REDUCTION (1F unit)	24
	WHITE LINE	24
	EXPANSION MODE	25
	DUAL FREQUENCY (2F unit)	26
	SCALE	26
	DEPTH SCALE GRID	26
	A-SCOPE	27
	NAVIGATIONAL INFO	27
	DEPTH UNIT	28
	DEPTH DISPLAY SIZE	28
	DEPTH DISPLAY POSITION	29
	TEMP. UNIT	29
	TEMP. DISPLAY SIZE	30
	TEMP. DISPLAY POSITION	30
	TEMP. ADJUSTMENT	31
	TEMP. GRAPH	31
	TEMP. SENSOR	32
	SPEED UNIT	32
	COLOR SETUP	33
	COLOR	33
	ALARM (2F unit)	34
	MJR FREQ (2F unit)	34
	SCALE FONT	34
	PIC. SPEED	34
	LANGUAGE	34



INITIAL SETTINGS

FACTORY SETTINGS

The ES-2035II is shipped from the factory with the functions under the following settings.
The user is able to re-set these functions.

FUNCTION	FACTORY SETTING (item in the box)	SETTINGS	
D RANGE	-3dB -4dB -5dB <input type="checkbox"/> ±6dB <input type="checkbox"/> +5dB +4dB +3dB	MENU DISPLAY <input type="checkbox"/> cf page 22	
TX POWER	<input type="checkbox"/> HIGH <input type="checkbox"/> LOW		
INTERF RED (1F unit)	<input type="checkbox"/> OFF <input type="checkbox"/> LOW <input type="checkbox"/> MID <input type="checkbox"/> HIGH		
WHITE LINE	<input type="checkbox"/> OFF <input type="checkbox"/> LOW <input type="checkbox"/> MID1 <input type="checkbox"/> MID2 <input type="checkbox"/> HIGH		
EXPN MODE	<input type="checkbox"/> NORMAL <input type="checkbox"/> CONST1 <input type="checkbox"/> CONST2 <input type="checkbox"/> CONST3 <input type="checkbox"/> AUTO		
DUAL FREQ (2F unit)	<input type="checkbox"/> HIGH <input type="checkbox"/> LOW <input type="checkbox"/> LOW <input type="checkbox"/> HIGH		
SCALE	<input type="checkbox"/> RIGHT <input type="checkbox"/> CENTER <input type="checkbox"/> OFF		
DEPTH GRID	<input type="checkbox"/> AUTO 1 2 5 10 20 50 100		
A-SCOPE	<input type="checkbox"/> OFF <input type="checkbox"/> ON		
NAVI INFO	<input type="checkbox"/> OFF <input type="checkbox"/> ON		
DEPTH UNIT	<input type="checkbox"/> m <input type="checkbox"/> fm <input type="checkbox"/> br <input type="checkbox"/> ft		
DEPTH DISP	OFF SMALL <input type="checkbox"/> MEDIUM <input type="checkbox"/> LARGE		
DEPTH POS.	<input type="checkbox"/> LOWER <input type="checkbox"/> UPPER		
TEMP UNIT	<input type="checkbox"/> ° C <input type="checkbox"/> ° F		
TEMP DISP	<input type="checkbox"/> OFF <input type="checkbox"/> SMALL <input type="checkbox"/> MEDIUM <input type="checkbox"/> LARGE		
TEMP POS.	<input type="checkbox"/> LOWER <input type="checkbox"/> UPPER		
TEMP ADJ	+0.0 (-9.9+9.9)		
TEMP GRAPH	<input type="checkbox"/> OFF <input type="checkbox"/> ON		
TEMP SENSOR	<input type="checkbox"/> OP-102 <input type="checkbox"/> OP-41 <input type="checkbox"/> NMEA0183		
SPEED UNIT	<input type="checkbox"/> kt <input type="checkbox"/> km / h		
COLOR SET	<input type="checkbox"/> A-1 <input type="checkbox"/> A-2 <input type="checkbox"/> B-1 <input type="checkbox"/> B-2 <input type="checkbox"/> C-1 <input type="checkbox"/> C-2		
COLOR	<input type="checkbox"/> 16 <input type="checkbox"/> 8		
ALARM (2F unit)	<input type="checkbox"/> LOW <input type="checkbox"/> HIGH		
MJR FREQ (2F unit)	<input type="checkbox"/> LOW <input type="checkbox"/> HIGH		
SCALE FONT	<input type="checkbox"/> SMALL <input type="checkbox"/> LARGE		
PIC. SPEED	<input type="checkbox"/> X1 <input type="checkbox"/> X2		
LANGUAGE	<input type="checkbox"/> ENGLISH <input type="checkbox"/> KOREAN <input type="checkbox"/> CHINESE <input type="checkbox"/> THAI		
RANGE (NORMAL RANGE)	0 TO 5m		KEY OPERATION (CONTROL PANEL)
PHASED RANGE	0		
BOTTOM EXPANSION	OFF		
AUTO RANGE	OFF		
AUTO SHIFT	OFF		
THRESHOLD	OFF		
PICTURE SPEED	1 / 1		
MODE SELECTION (2F unit)	DUAL (HIGH LOW)		
INTERF RED (2F unit)	OFF		

RETURN TO FACTORY SETTINGS (INITIAL SETTINGS)

Ensure the power supply switch is turned off and then hold the  key and  key at the same time so that the message "ALL IMPLEMENTED DATA RETURNED TO FACTORY SETTINGS" appears on the screen after the beep stops.

Note that it would not be returned to the factory settings if the  key is released before the beep stops. After this operation all functions will then return to the factory settings.

USER SETTINGS

In addition to the factory settings it may also be set to the functions selected by the user. This function is called USER SETTING. The user may easily set the desired function settings to fit his preference by operating as explained below.

With this function the user may return to the desired function settings if the unit should become inoperable due to mistaken use of the controls.

Please be sure to memorize user settings at the time the unit is first operated.



Write down your user settings in case they are accidentally changed, or you wish to use different combinations for different fisheries. i.e. mid water vs. bottom.

1. HOW TO MEMORIZE USER SETTINGS

Set all functions and display units to the desired settings on the MENU display.

cf page 22



Once all functions have been changed, press  key to turn the power off.

Next while pressing the  key, hold the  key so that the message "memorized the initial settings" appears on the screen. Note that it would not be memorized if the  key is released before the beep stops.

After this operation all functions will be memorized under user setting.

2. RETURN TO USER SETTINGS

Once press  key to turn the power off to return to user settings.

Next while pressing the  key, hold the  key so that the message "memorized the initial settings" appears on the screen and then an echo sounder mode is displayed.

After this operation all functions will return to the user setting.



3. REVISE USER SETTINGS

Reset all functions as required and then memorize the settings by proceeding the item 1, HOW TO MEMORIZE THE USER SETTINGS.



MENU

This provides you the initial explanation for functions of the sounder.
Please set each function before using the ES-2035II to suit individual needs.

Press  key to call MENU display so that the last selected menu will be displayed and highlighted.

Use the  or  key to highlight the item to be set.

RANGE KEY

Use the  or  key to set the desired range values.

PHASED RANGE KEY

The menu screen will disappear from the screen by pressing the  key.

[DUAL FREQUENCY]

MENU

D RANGE	±6dB
TX POWER	HIGH
WHITE LINE	OFF
EXPN MODE	NORMAL
DUAL FREQ	HIGH I LOW
SCALE	RIGHT
DEPTH GRID	AUTO
A-SCOPE	OFF
NAVI INFO	OFF
DEPTH UNIT	m
DEPTH DISP	MEDIUM
DEPTH POS.	LOWER
TEMP UNIT	°C
TEMP DISP	OFF
TEMP POS.	LOWER
TEMP ADJ	+ 0.0
TEMP GRAPH	OFF
TEMP SENSOR	OP-102
SPEED UNIT	kt
COLOR SET	A-1
COLOR	16
ALARM	LOW
MJR FREQ	LOW
SCALE FONT	SMALL
PIC. SPEED	X1
LANGUAGE	ENGLISH
PIC. SPEED	X1

PUSH RANGE KEY
MOVE ITEM SEL.
PUSH PHASED R. KEY
SET VALUE

VER * **
**** * **

[SINGLE FREQUENCY]

MENU

D RANGE	±6dB
TX POWER	HIGH
INTERF RED	OFF
WHITE LINE	OFF
EXPN MODE	NORMAL
SCALE	RIGHT
DEPTH GRID	AUTO
A-SCOPE	OFF
NAVI INFO	OFF
DEPTH UNIT	m
DEPTH DISP	MEDIUM
DEPTH POS.	LOWER
TEMP UNIT	°C
TEMP DISP	OFF
TEMP POS.	LOWER
TEMP ADJ	+ 0.0
TEMP GRAPH	OFF
TEMP SENSOR	OP-102
SPEED UNIT	kt
COLOR SET	A-1
COLOR	16
SCALE FONT	SMALL
PIC. SPEED	X1
LANGUAGE	ENGLISH

PUSH RANGE KEY
MOVE ITEM SEL.
PUSH PHASED R. KEY
SET VALUE

VER * **
**** * **



Rom version and the date

Each function will be explained in the following pages.

1. D RANGE (DYNAMIC RANGE)

By shifting the dynamic range, the user is able to discriminate more precisely the size, depth and density of the fish school.

Experimenting with this function will give you the best setting for various fishing operations.

Each press of  or  key changes the dynamic range level.

PHASED RANGE KEY

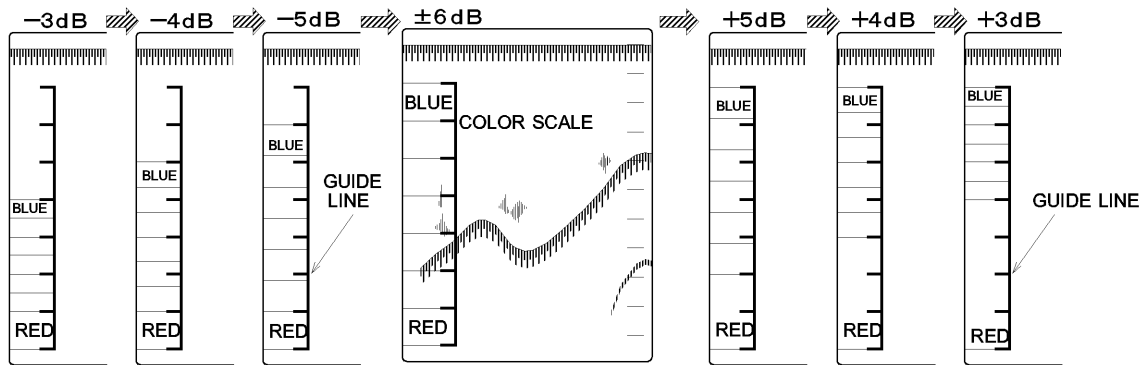

(±6dB...+5dB...+4dB...+3dB...-3dB...-4dB...-5dB...±6dB)



This diagram shows the comparative signal threshold levels to the standard ±6dB for the dynamic ranges.

2. TX POWER

The output power of the ultrasonic sound wave may be selected.

Each press of  or  key changes the output power either "HIGH or LOW.

PHASED RANGE KEY

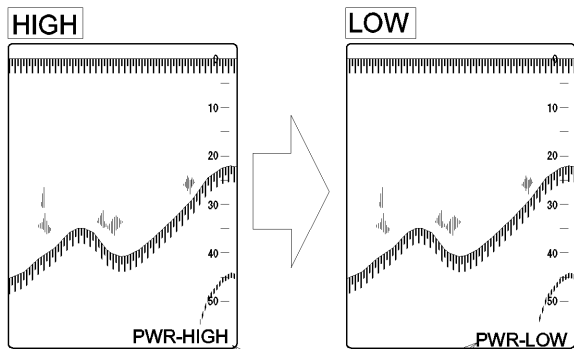



DISPLAYED TX POWER LEVEL

The current TX POWER level is displayed at the right down corner of the screen.

- Displayed TX POWER level
- { HIGH : PWR-HIGH
- LOW : PWR-LOW

3. INTERFERENCE REDUCTION (SINGLE FREQUENCY UNIT only)

Interference generated by nearby fishing vessels can be reduced on the screen.

Each press of the  or  key changes the level of reduction.

PHASED RANGE KEY

(IR-OFF...IR-LOW...IR-MID...IR-HIGH appears on the top screen.)

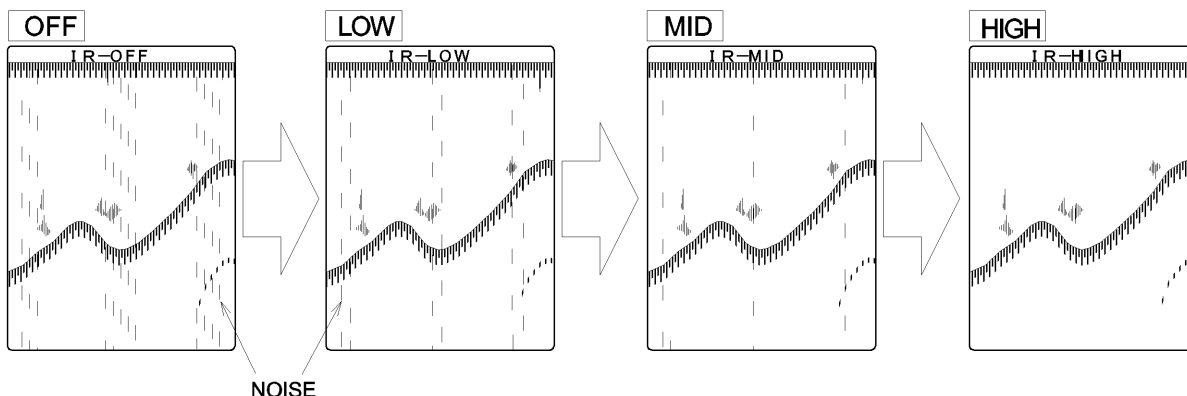

When OFF is selected, Interference reduction function is inactive and when HIGH is selected, it is the highest level of Interference reduction.



Some types of noise intereferency may not be reduced. Do not select excessive level than the one to be needed since the weak echoes may be erased.

4. WHITE LINE

The function of the White line is to help in discriminating the bottom and fish lying on or very close to the bottom.

Each press of the  or  key changes the White line control level.

PHASED RANGE KEY

(OFF...LOW...MID 1...MID 2...HIGH appears on the top screen.)

When OFF is selected, this function is inactive and when the higher level is selected, it blanks out wider just below the line.

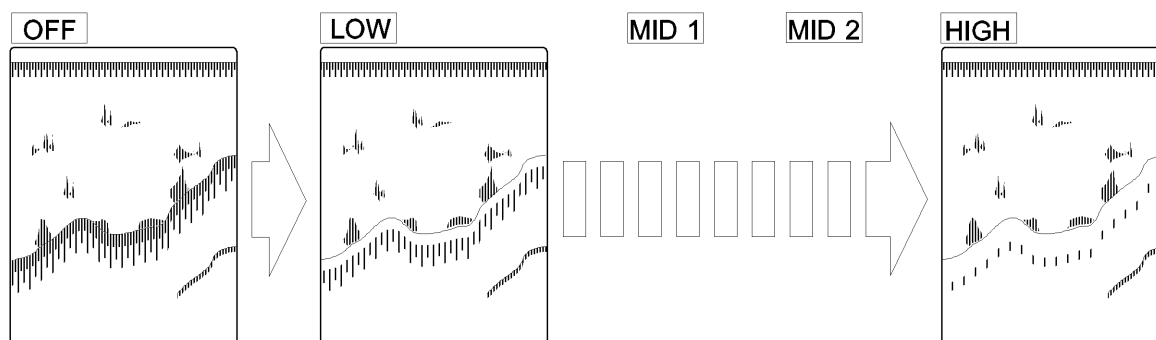

5. EXPANSION MODE

When you activate Normal / Bottom Expansion Mode, as in the drawing in the below, the areas of the bottom contour can be selected by the following shifts and displayed across the screen for close observation of the echoes of interest on or near of the bottom. **cf** PAGE 37/42

Each press of the  or  key changes the setting.
PHASED RANGE KEY

"NORMAL...CONST1...CONST2...CONST3...AUTO"

When the bottom expansion mode is selected, the expansion range line appears on the screen. The amount of expansion can be adjusted by using the expansion key.

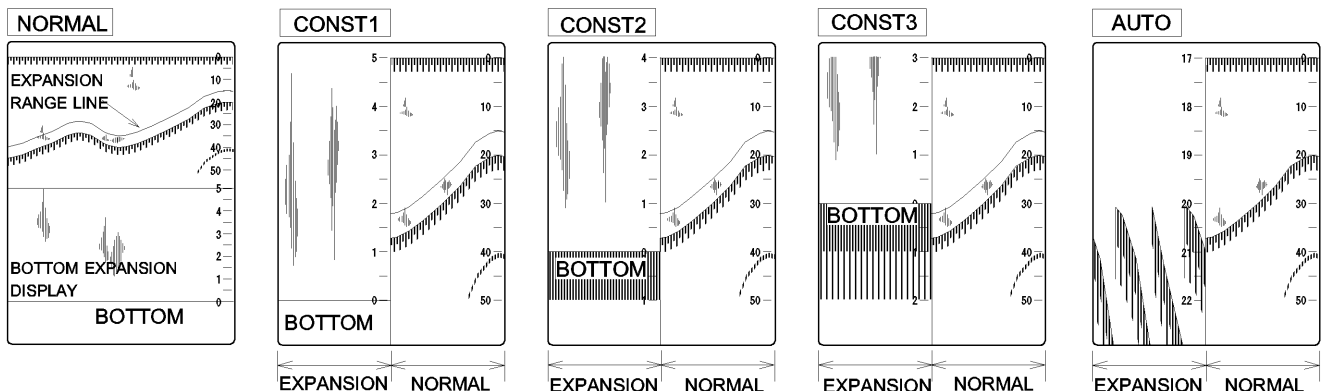

- NORMAL: The expansion area can be displayed in the lower 1/2 of the screen. Being based on the bottom the amount is set by using the expansion key
- CONST1 : The same display as NORMAL is displayed in the left 1/2 of the screen.
- CONST2 : The bottom position shifted 1/5 higher than the one of CONST1 an be displayed in the left 1/2 of the screen.
- CONST3 : The bottom position shifted 2/5 higher than the one of CONST1 an be displayed in the left 1/2 of the screen. The bottom area can be magnified for better separation of echoes.
- AUTO : The expansion area of the bottom can be detected automatically and displayed in the left lower 1/2 of the screen.



Note that this expansion mode settings other than NORMAL are disable in case DUAL FREQUENCY MODE or SMALL TARGET mode is activated.

6. DUAL FREQUENCY (DUAL FREQUENCY UNIT only)

The position of the dual frequency displays can be set.

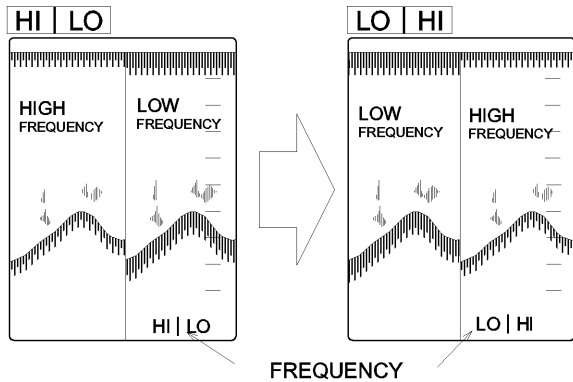

Each press of the  or  key changes the position either "HI | LO" or "LO | HI".
PHASED RANGE KEY



- HI | LO : High frequency display in the left 1/2 of the screen.
Low frequency display in the right 1/2 of the screen.
- LO | HI : Low frequency display in the left 1/2 of the screen.
High frequency display in the right 1/2 of the screen.

7. SCALE

The depth scale can be toggled ON/OFF and its display position can be selected.

Each press of the  or  key changes the displayed position of the depth scale.
PHASED RANGE KEY

"RIGHT...CENTER...OFF...RIGHT".

- RIGHT : The depth scale positions in the right side of the screen
- CENTER : The depth scale positions in the center of the screen.
- OFF : The depth scale is disable.

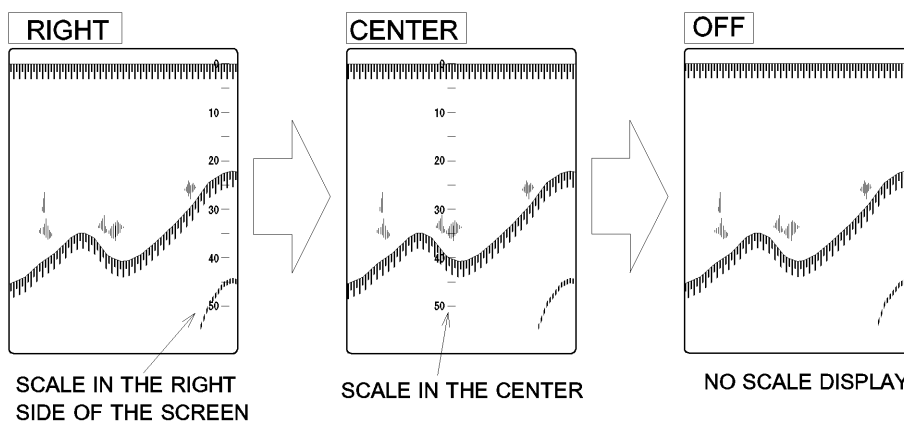

8. DEPTH SCALE GRID (DEPTH GRID)

The depth scale grid can be adjustable with the phased range keys.

Each press of the  or  key change the scale grid,
PHASED RANGE KEY

"1 - 2 - 5 - 10 - 20 - 50 -100 - AUTO".

9. A-SCOPE

The amplitude scope which appears in the right side of the echo display, can be turned on and off.

Each press of the  or  key alternates ON with OFF.
PHASED RANGE KEY

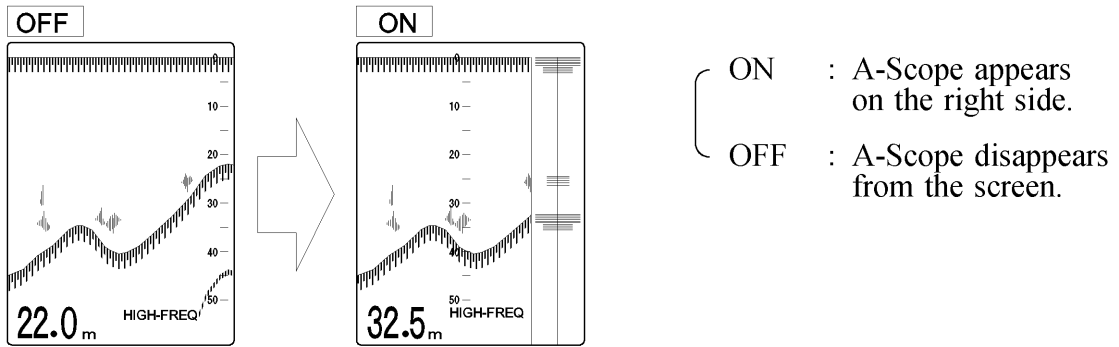

10. NAVIGATIONAL INFORMATION

The navigational information which appears in the left center of the echo display, can be turned on and off.

Each press of the  or  key alternates ON with OFF.
PHASED RANGE KEY

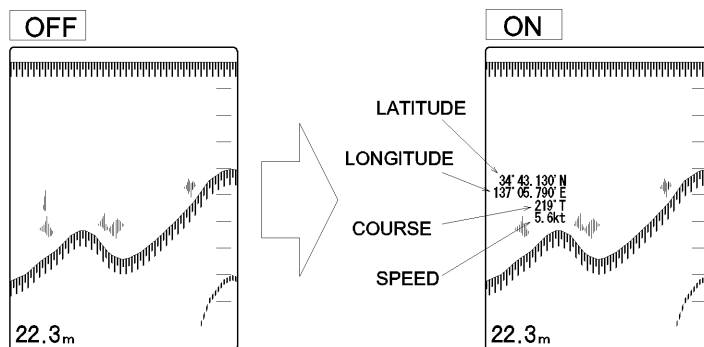

NOTE !

To present the navigational information in the display will require that a navigator is connected via the NMEA (NMEA-0183) input port.

The ship's speed unit can be displayed either "kt" or "km/h". **cf** PAGE 32

11. DEPTH UNIT

The unit of depth may be selected.

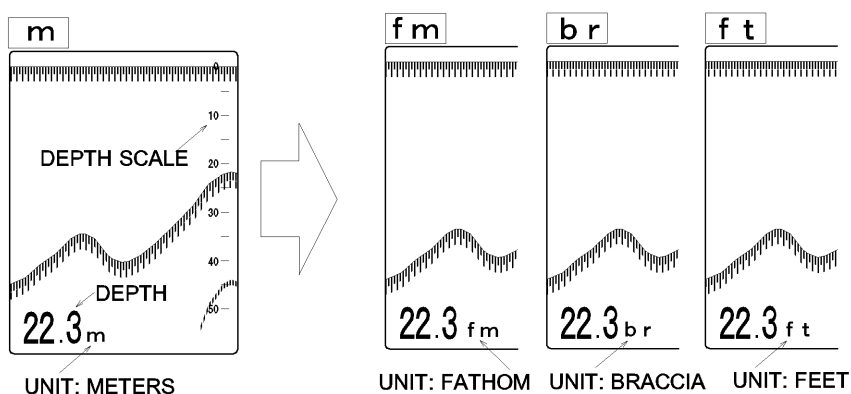

Each press of the  or  key changes the unit.
PHASED RANGE KEY

- m : to display the unit meters.
- fm : to display the unit fathom. (1fm: 1.8288m)
- br : to display the unit braccia. (1br: 1.65m)
- ft : to display the unit feet. (1ft: 0.3048m)



12. DEPTH DISPLAY SIZE

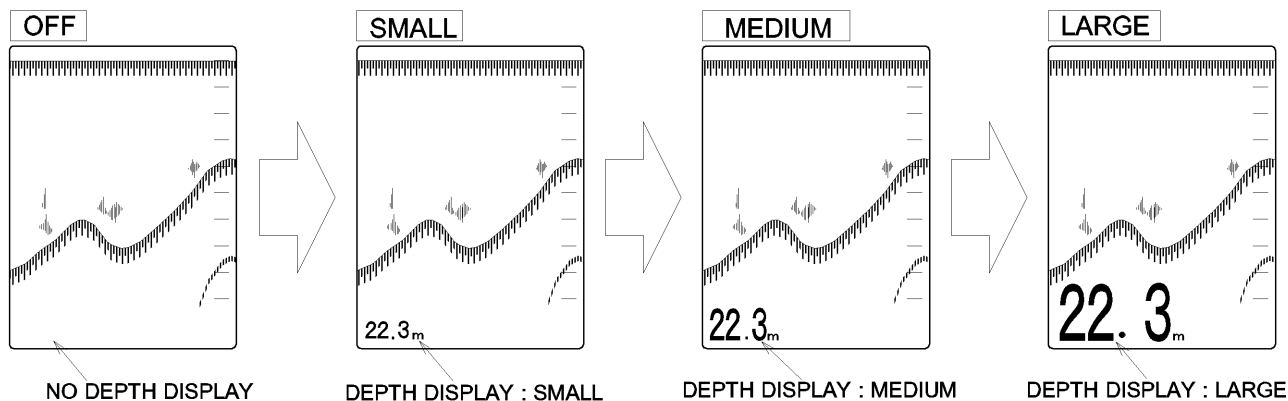

The size of depth display may be selected.

Each press of the  or  key changes the size. (OFF...SMALL...MEDIUM...LARGE)
PHASED RANGE KEY



13. DEPTH DISPLAY POSITION

The position of depth display may be selected.

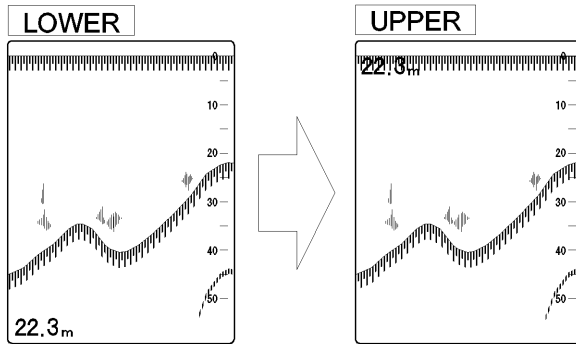

Each press of the  or  key changes the position either "UPPER" or "LOWER".
PHASED RANGE KEY



- LOWER : Current depth values appear in the down left of the screen.
- UPPER : Current depth values appear in the upper left of the screen.

14. TEMPERATURE UNIT

The unit of water temperature display may be selected when an optional water temp. sensor connected.

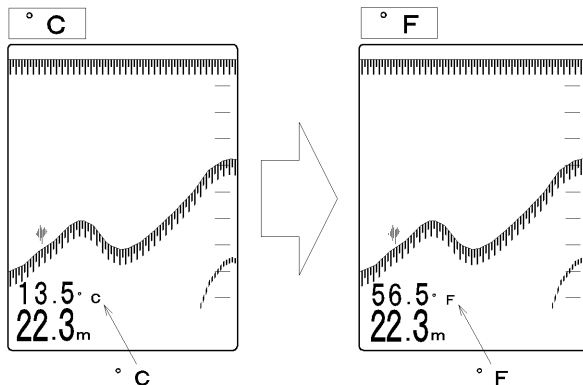

Each press of the  or  key changes the unit either ° C or ° F .
PHASED RANGE KEY



- ° C : Celsius
- ° F : Fahrenheit

15. TEMPERATURE DISPLAY SIZE

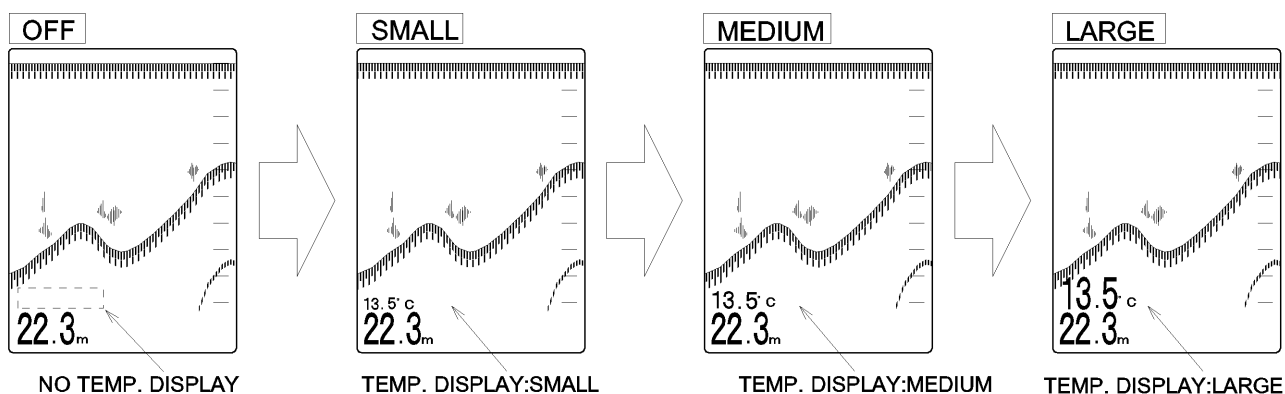

The size of water temperature display may be selected when an optional water temp. sensor connected.

Each press of the  or  key changes the size. "OFF...SMALL...MIDDLE...LARGE"
PHASED RANGE KEY



16. TEMPERATURE DISPLAY POSITION

The position of water temperature display may be selected when an optional water temp. sensor connected.

Each press of the  or  key changes the position either "UPPER" or "LOWER".
PHASED RANGE KEY

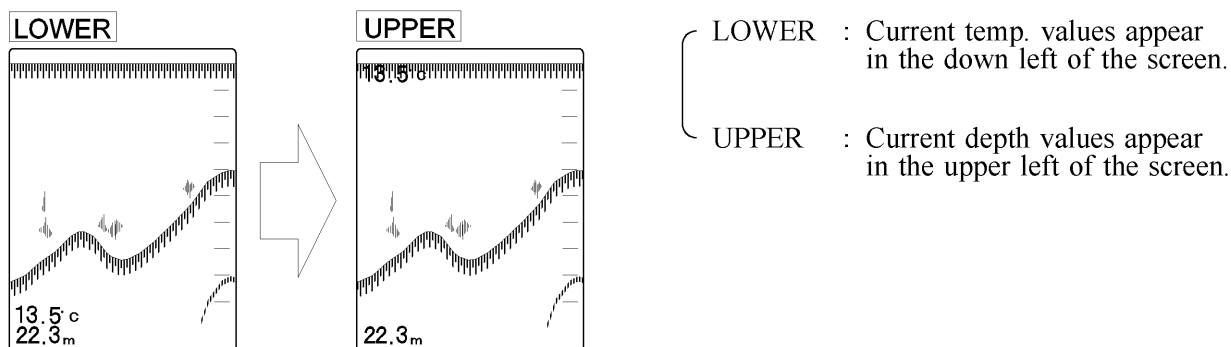



NOTE !

Please select OFF while disconnecting the temp. sensor.

When TEMP DISP "SMALL ~ LARGE" selected, displayed temp. unit sometimes disturb the display on the screen.

17. TEMPERATURE ADJUSTMENT

To adjust the water temperature displayed in the screen with an optional water temp. sensor connected.

Every time the  or  key is pressed, it is adjusted by 0.1° in

PHASED RANGE KEY

the range from - 9.9 to + 9.9.

{	+ 9 . 9	: The maximum temperature adjustment
	0 . 0	↑ : No adjustment
	- 9 . 9	↓ : The minimum temperature adjustment

 : increases the values.

 : decreases the values.

PHASED RANGE KEY

18. TEMPERATURE GRAPH

To select the display of the Temperature Graph either ON or OFF when an optional water temperature sensor is connected.

Each press of the  or  key alternates On with OFF.

PHASED RANGE KEY

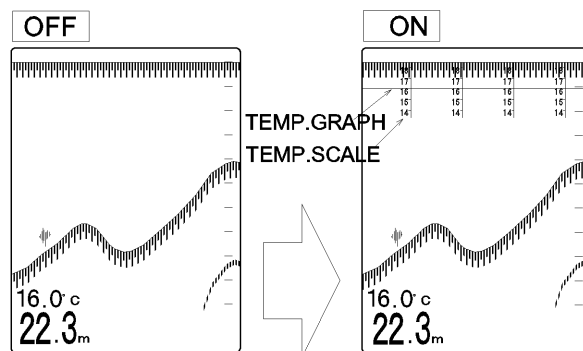

To present a temperature graph and a scale will require that the ES-2035II is connected to an optional temp. sensor (OP-102 or OP-41) or via the NMEA-0183 input port.

Temperature graph and scale are disable when OFF selected.

19. TEMPERATURE SENSOR

To select the connection type of the Temperature sensor when it is connected.

Each press of the  or  key changes, "OP-102...OP-41...NMEA0183...OP-102..." accordingly.

PHASED RANGE KEY



Temperature sensor connections of OP-102 or OP-41 are made to the receptacle on the rear of the cabinet - turn the plug's coupling ring clockwise. Note that this plug is option.

NMEA0183 connections are made to the receptacle on the rear of the cabinet - turn the plug's coupling ring clockwise. Note that this plug is option.

The positions of each port can be shown in the Electrical connection, the page 16.

20. SPEED UNIT

The unit of ship's speed display may be selected when an external navigator connected.

Each press of the  or  key changes the unit either "kt" or "km/h".

PHASED RANGE KEY

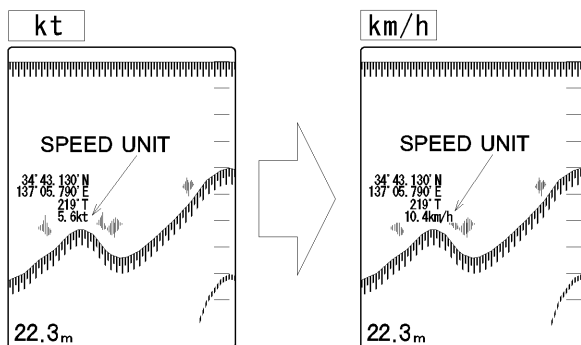

- kt : Speed can be shown in knots.
- 1kt (nm) = 1.852 km/h
- km/h : Speed can be shown in kilometers/hour.

21. COLOR SETUP (COLOR PALETTE FUNCTIONS)



There is a total of 6 palettes, A-1, A-2, B-1, B-2, C-1 and C-2.
A-1, A-2, B-1 and B-2 are fix and therefore not adjustable.

Palette C-1 and C-2 can be customized to suit individual needs and wishes.
The initial settings: C-1=A-1 and C-2=B-1

Each press of the  or  key changes the palette setup.
PHASED RANGE KEY

"A-1...A-2...B-1...B-2...C-1...C-2...A-1...".



{ A-1 · A-2 · B-1 · B-2 : fix and not adjustable
C-1 · C-2 : make your own special palette setup

Press  or  key to select C-1 or C-2 and then press the  Threshold key
PHASED RANGE KEY



to display the menu if you wish to make your own special palette setup,

Use the  Threshold key to move the frame to the level to be set.

Each numeral color intensity (R: red, G: green, B: blue) will be displayed on the menu.



Use the  or  key to highlight the color to be changed and select the color intensity
RANGE KEY

(1 ~ 15) with the  or  key.
PHASED RANGE KEY

Once the color palette has been set, press the  key to return to Menu display and
press the  key to return to sounder display, which will memorize the color setup in
C-1 or C-2.



22. COLOR

The color presentation can be selected either 8-color or 16-color presentation.

Each press of the  or  key changes the color presentation either "8" or "16".
PHASED RANGE KEY

23. ALARM (DUAL FREQUENCY UNIT ONLY)



To set to sound a "beep" whether in the high frequency display or low frequency display.

Each press of the  or  key changes either "LOW" or "HIGH" .
PHASED RANGE KEY

The active zone is indicated by alarm markers (↙ ↘) in the right side of the selected frequency display.

24. MJR FREQ - PRIOR FREQUENCY of DEPTH MEASUREMENT (DUAL FREQUENCY UNIT ONLY)



To select main frequency to measure the depth while performing dual frequency.

Each press of the  or  key changes either "LOW" or "HIGH" .
PHASED RANGE KEY

In case the selected frequency is disabled the other frequency may be activated automatically.



25. SCALE FONT

The size of the depth scale and its value on the screen can be selected.

Each press of the  or  key changes the size either "SMALL" or "LARGE" .
PHASED RANGE KEY

26. PICTURE SPEED

The rate that the picture travels from right to left on the screen can be selected.

Each press of the  or  key changes the speed either "X1" or "X2" .
PHASED RANGE KEY

27. LANGUAGE

To select the display text on the screen.

Each press of the  or  key changes the display language.
PHASED RANGE KEY

The following display languages to choose from: English, Thai, Korean and Chinese.

OPERATION of DIALS and KEYS

This chapter explains how to operate the ES-2035II echo sounder.

KEY OPERATION	RANGE KEYS	36	
	PHASED RANGE KEYS	36	
	EXPANSION RANGE KEYS	37	
	VRM KEYS	37	
	ALARM KEYS	38	
	ALARM/ENTRY KEY	40	
	THRESHOLD KEY	40	
	PICTURE SPEED KEY	41	
	MODE SELECTION KEY (2F)	42	
	INTERFERENCE REDUCTION KEY (2F) ..	44	
	AUTO RANGE	45	
	AUTO SHIFT	45	
	DIAL OPERATION	STC CONTROL DIALS	46
		NOISE SUPPRESSION DIAL	46
GAIN CONTROL DIALS		47	
BRIGHTNESS CONTROL DIAL		47	

KEY OPERATION

RANGE KEYS

RANGE KEYS allow the operator to select a specific range.

The displayed range can be selected 0 to 5 and going to 2000m, fm, br, and 0 to 15 and going to 5000 feet in 17 steps.

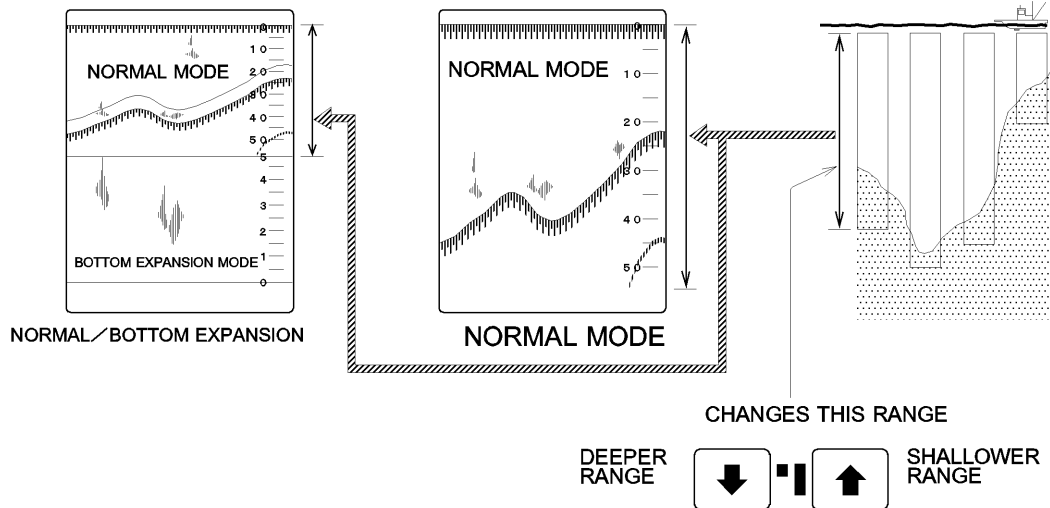

VARIABLE RANGES

m, fm, br : 0 to 5, 10, 15, 20, 30, 40, 50, 60, 80, 100, 150, 200, 300, 500, 1000, 1500, 2000

feet : 0 to 15, 20, 30, 40, 50, 60, 80, 100, 150, 200, 300, 500, 1000, 1500, 2000, 3000, 5000

PHASED RANGE KEYS

PHASED RANGE KEYS allow the user to set the displayed depth range to begin at some point below the surface.

When this key is pressed, the display of start depth will become deeper.



When this key is pressed, the display of start depth will become shallower.



CHANGES THIS RANGE

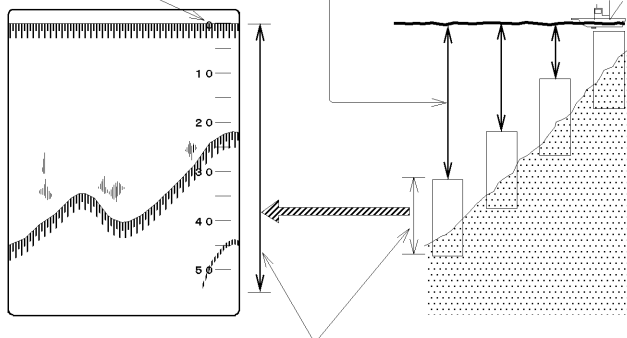

This range is selected with the range keys.

For the selection of the depth start point at the top of the screen.

Phased range value is possible to be changed every 2/5 of the selected range (max. 999m/br/fm, or 2999ft).

This function may be used to show the desired area expanded on the screen.

EXPANSION RANGE KEYS

NORMAL DISPLAY and EXPANSION DISPLAY selected in MENU, EXPN MODE. appears on the screen at the same time.

The amount of expansion can be adjusted with these keys. **cf** page 25

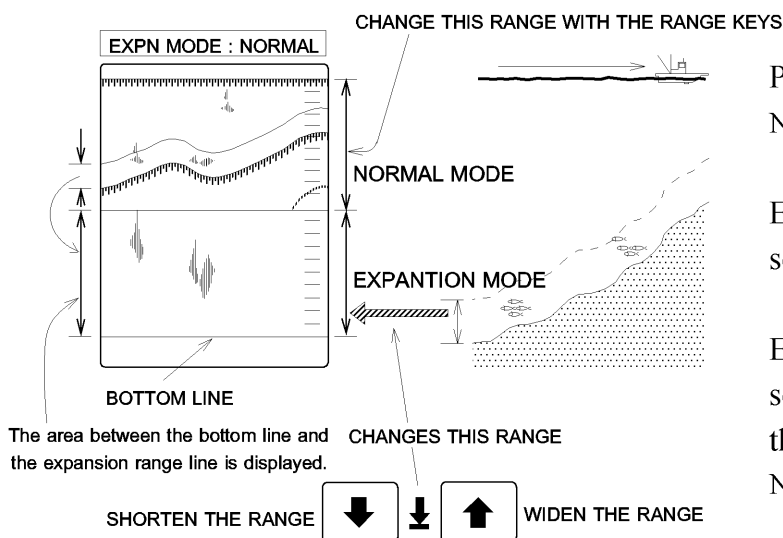

Pressing the key displays the NORMAL/EXPANSION MODE.

Each press of the key changes the setting wider.

Each press of the key changes the setting shallower and at the shallowest end this function will be released and back to NORMAL MODE only.

VARIABLE RANGES

m, fm, br : 0 to 1, 2.5, 5, 10, 20, 50, 100, 250

feet : 0 to 5, 10, 20, 50, 100, 250, 500, 1000

VRM KEYS

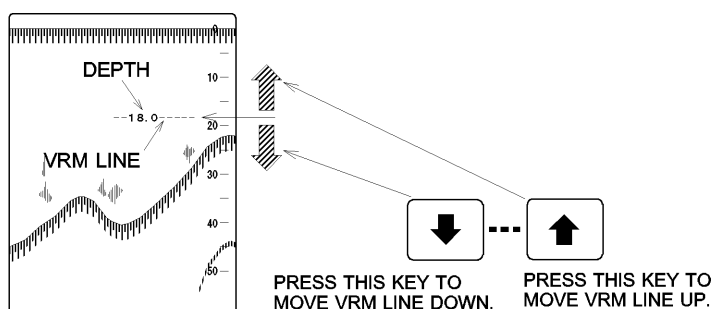

If you want to monitor a particular depth in greater detail then the marker line is a very convenient method.

Press the or key to activate the line on the screen.

NOTE !

The VRM line can be inactivated by pressing the and key at the same time.

However this can be memorized and appears on the screen by pressing the or key again.





ALARM KEYS

Alarms can be set to sound a "beep" if the depth is above (SHALLOW ALARM) or below (DEEP ALARM) the set alarm depth.

It can be also set to sound if any object appears between the two set points (FISH ALARM).

1. SHALLOW ALARM

The shallow alarm will sound if the bottom moves shallower out of a specified zone.



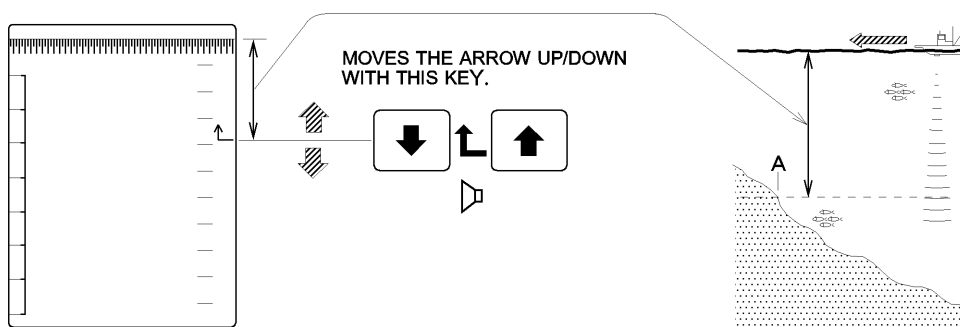

To use the alarm as Shallow alarm only, press  or  key to move the arrow () to the desired position and press  key to set the desired alarm depth.

In case of the below the alarm sounds at the point A.



2. DEEP ALARM

The shallow alarm will sound if the bottom moves deeper out of a specified zone.

To use the alarm as Deep alarm only, press  or  key to move the arrow () to the desired position and press  key to set the desired alarm depth.

In case of the below the alarm sounds at the point B.

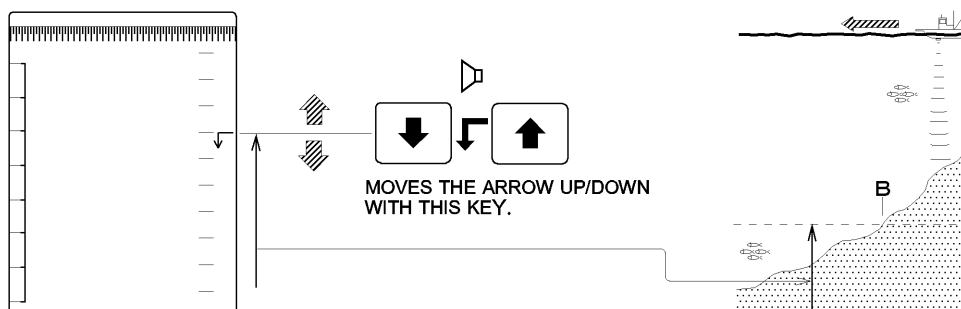

3. FISH ALARM

The Fish alarm mode will alert you if any object appears between the two set points (Deep alarm arrow $\sqrt{\quad}$ and Shallow alarm arrow $\uparrow\quad$).

In case of the below the alarm sounds at the point C.

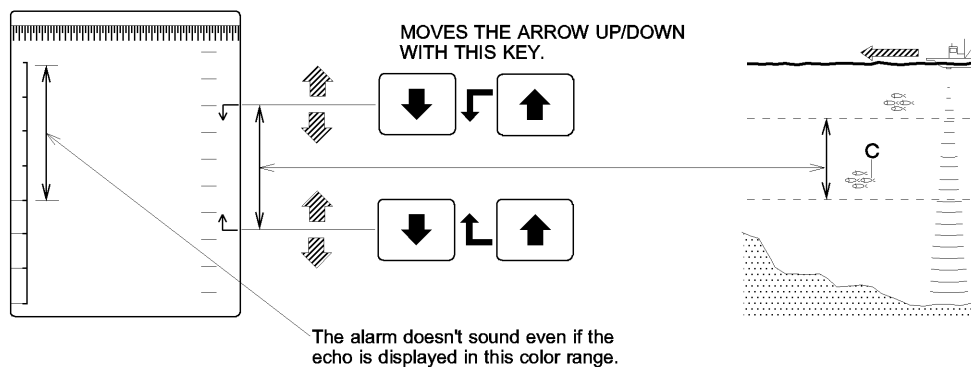

NOTE !

-SHALLOW ALARM : Press the $\downarrow\leftarrow$ key to activate the Shallow alarm arrow ($\uparrow\quad$).

At the top end the arrow disappears from the screen.

-DEEP ALARM : Press the $\rightarrow\uparrow$ key to activate the Deep alarm arrow ($\sqrt{\quad}$).

At the bottom end the arrow disappears from the screen.

-The alarm sounds when the echo sounder reflects the colors of the arrow setting, which can be set by using the Threshold key. **cf** PAGE 40

This function is effective until the arrows are moved.

-Press $\leftarrow\rightarrow$ key to release the alarm settings. **cf** PAGE 40

ALARM / ENTRY KEY

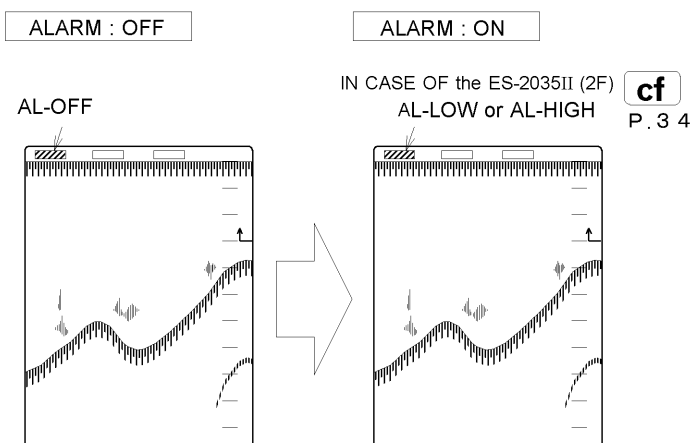

Move the arrow to the desired position and press the  key to set the desired alarm depth.

Pressing the  key again will release the alarm after setting the alarm depth.

Press the  key to inactive MENU display.

THRESHOLD KEY

To remove and recall weaker echoes by color scale from the screen.

Each time this key  is pressed the weakest color will be erased.

WHAT IS "THRESHOLD" ?

~~~~~

The equipment will pick up and display unwanted echoes from small objects in the water. With the threshold function it is possible to eliminate these unwanted echoes from the screen.

~~~~~

PICTURE SPEED KEY

The picture speed rate may be selected from the following.

Each press of the  key changes the setting.

PICTURE SPEED KEY

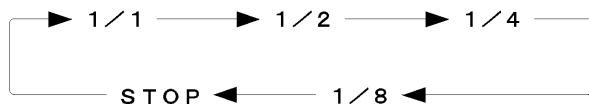

The selected rate can be displayed at the center top of the screen.

PICTURE SPEED DISPLAY
PF-1/1

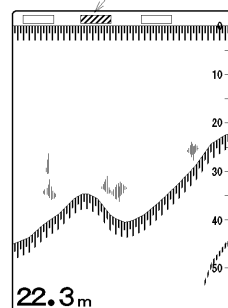

EXAMPLE

As you see in the Fig.1 the ship travels from point A to B. In case of the higher rate of movement of the targets on the display screen, moving from right to left, it will be adjusted like Fig.2. and in case of the lower rate of movement of the targets on the display screen, it will be adjusted like Fig.3.

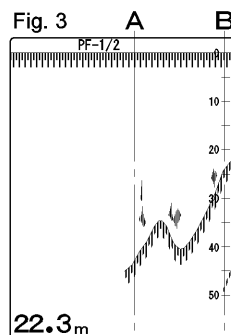
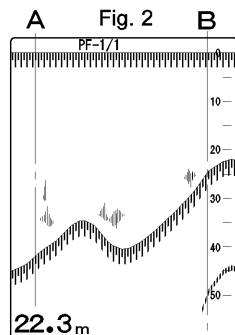
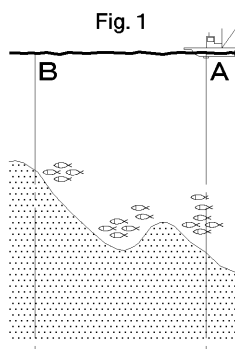

WHAT IS "PICTURE SPEED" ?

Picture speed rate refers to the speed the picture travels from right to left on the screen. 1/1 refers to 1 vertical line of picture per 1 sound transmission, and 1/2 refers to 1 vertical line of picture per 2 sound transmissions. There is no relation to ship speed.

MODE SELECTION KEY (DUAL FREQUENCY UNIT only)

Depending on your requirements you can select one of the following modes.

Each press of the **MODE** key changes the mode as below.

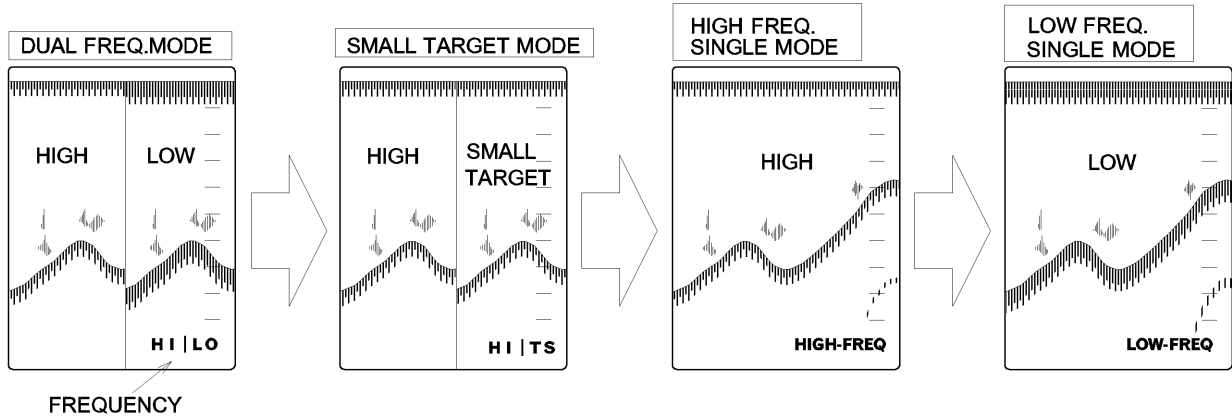
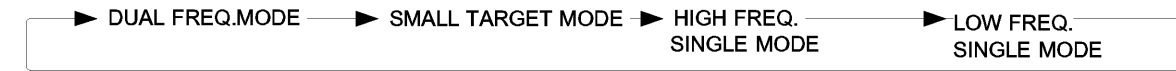

DUAL FREQUENCY MODE : The actual displays are relevant to the settings of the MENU, "DUAL FREQ."

SMALL TARGET : "SMALL TARGET MODE" in the right 1/2 of the split screen and "DUAL FREQ." in the left 1/2 of the split screen. **cf** PAGE 26

1. DUAL FREQUENCY MODE

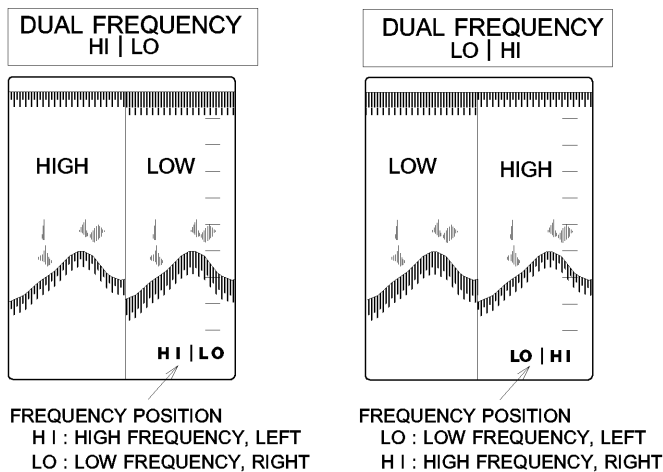

The screen is vertically divided into two and the high frequency display and the low frequency display are presented on the same screen.

The display positions may be relevant to the setting of the MENU, "DUAL FREQ".

cf PAGE 26

2. SMALL TARGET MODE

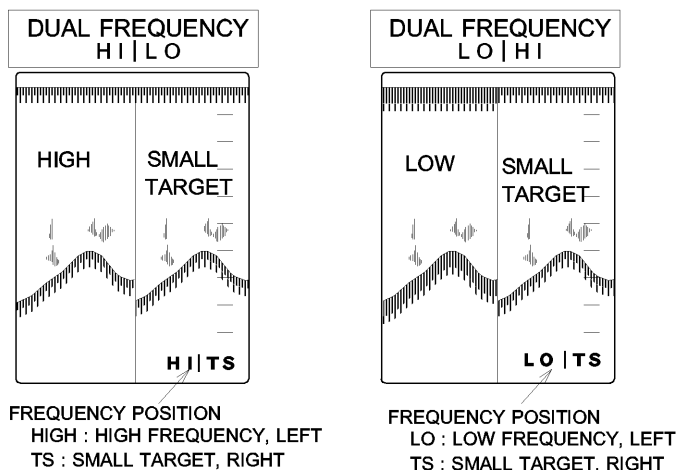

The screen is vertically divided into two and the small target mode, right and the high or low frequency display, left are presented on the same screen.

The displayed mode on the half left display is relevant to the setting of the MENU, "DUAL FREQ".

cf PAGE 26

WHAT IS "SMALL TARGET MODE" ?

The advantage of a high frequency (200kHz) is that smaller objects and fish, SHIRASU (sardine fry etc.) can be pinpointed, which is the disadvantage of a low frequency (50kHz).

In the below high/low frequency display, only the high frequency display is able to distinguish the small fish, SHIRASU. In order to make the small fish targets (SHIRASU) easier to see, SHIRASU can be displayed in the normal color and others can be displayed in a lighter color by selecting the SMALL TARGET MODE.

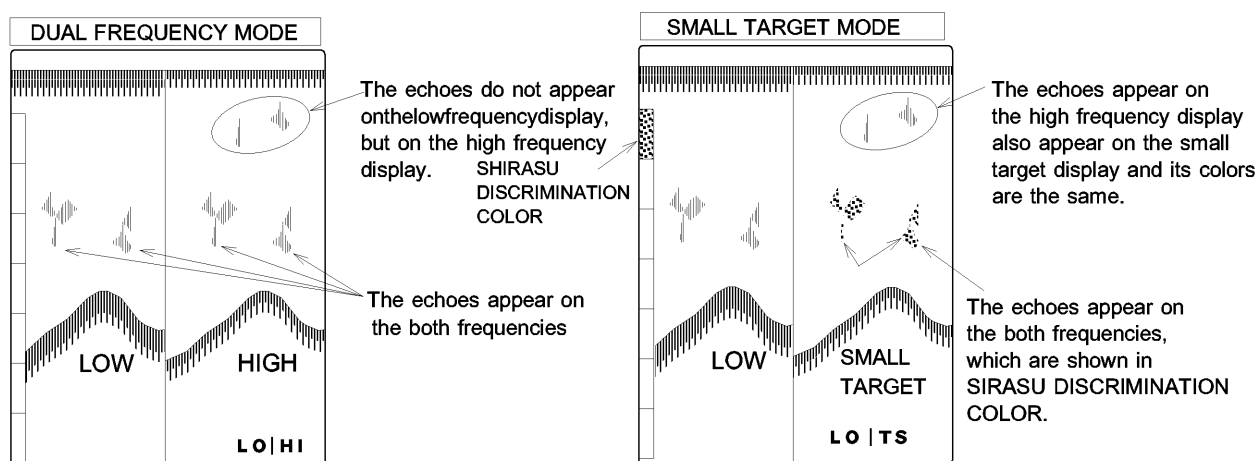

- The small targets can sometimes appear on the both high and low frequency display depending on the Gain control level.
- The SHIRASU discrimination color is shown on the top of Color scale.

3. HIGH or LOW FREQUENCY SINGLE MODE

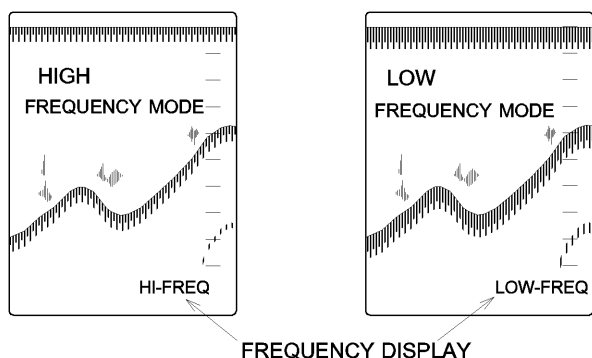

Either HIGH FREQUENCY SINGLE MODE or LOW FREQUENCY SINGLE is displayed on a full screen.

INTERFERENCE REDUCTION KEY (DUAL FREQ. UNIT only)

Interference generated by nearby fishing vessels can be reduced on the screen.

Each press of the  key changes the level of reduction.

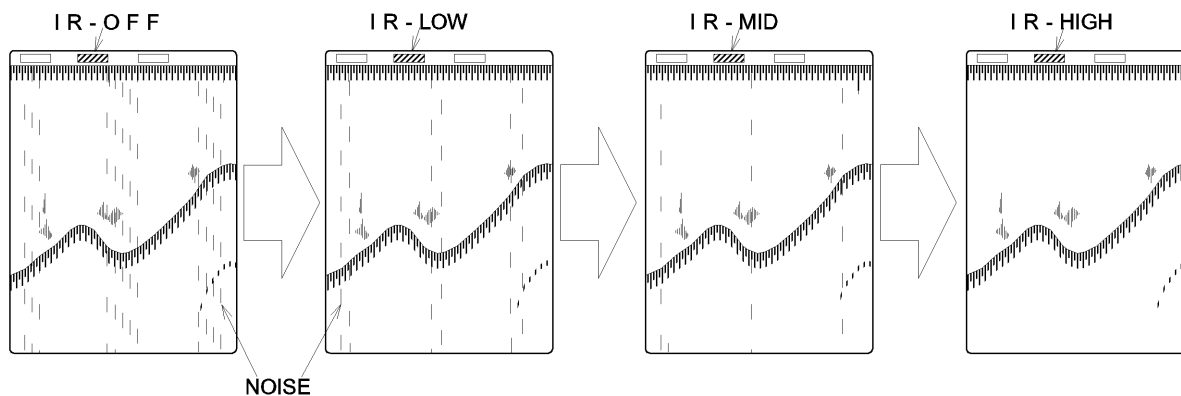
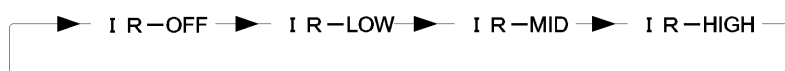

Some types of noise interference may not be reduced. Do not select excessive level than the one to be needed since the weak echoes may be erased.



WHAT IS "INTERFERENCE REDUCTION" ?

By receiving sound waves from a neighboring ship's equipment the noise appears on the screen like sprinkling rain.

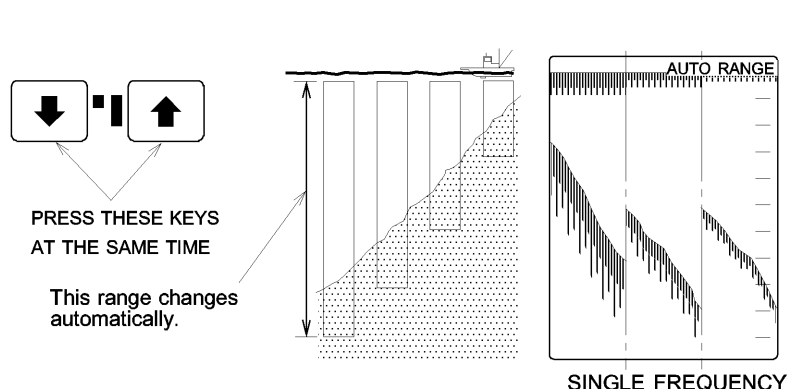

AUTO RANGE FUNCTION

The range will change automatically to always show the full depth from transducer face to sea bottom regardless of changes in depth.



Press both  &  Range keys at the same time to start the auto range function.



When this function is activated, "AUTO RANGE" will be displayed in the right of the top screen.

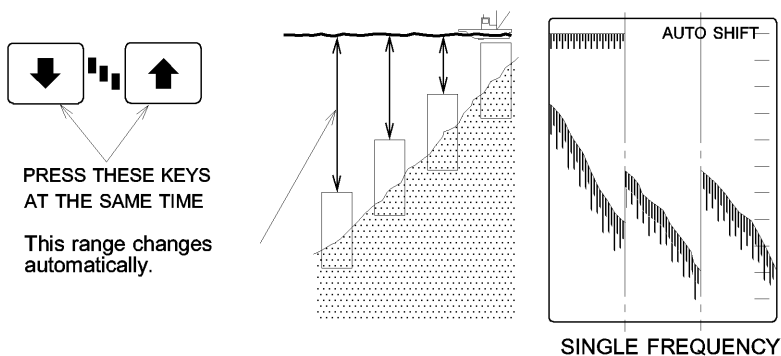

Press either  or  Range key at the same time to release the auto range function.

AUTO SHIFT FUNCTION

The phased range will change automatically to always track the bottom in the specified range.



Press both the  &  Phased range keys at the same time to start the auto shift function. When this function is activated, "AUTO SHIFT" will be displayed in the right of the top screen.

Press either  or  Phased range key at the same time to release the auto shift function.

NOTE !

~~~~~  
For auto range and auto shift functions to work successfully, the sea bottom echo must be in red or orange which are the strongest scale colors.

Even when the sea bottom echo is in red or orange, if there is interference due to bubbles etc., the function may not be able to track the bottom. In this case, if the bottom is not located after 16 transmissions, the depth scale will return to 0 and start searching again. If the function is unable to locate the bottom the scale will continue to fluctuate.  
~~~~~

DIAL OPERATION

STC CONTROL DIALS

To reduce receiver gain for shallow water echoes and restores it with depth in such a manner as to equalize echo strengths at different depths.

The STC control function is at maximum in the fully counterclockwise position.

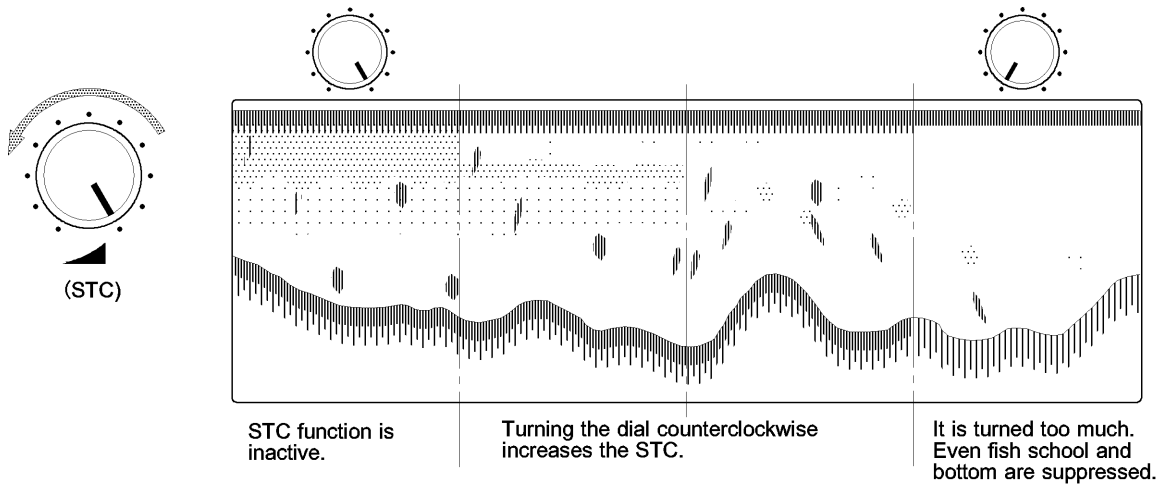

Note that turning too much to counterclockwise suppresses even fish school or bottom signal.

NOISE SUPPRESSION DIAL

The noise cluttering the entire screen can be reduced by adjusting this dial.

The noise suppression dial function is at maximum in the fully clockwise position.

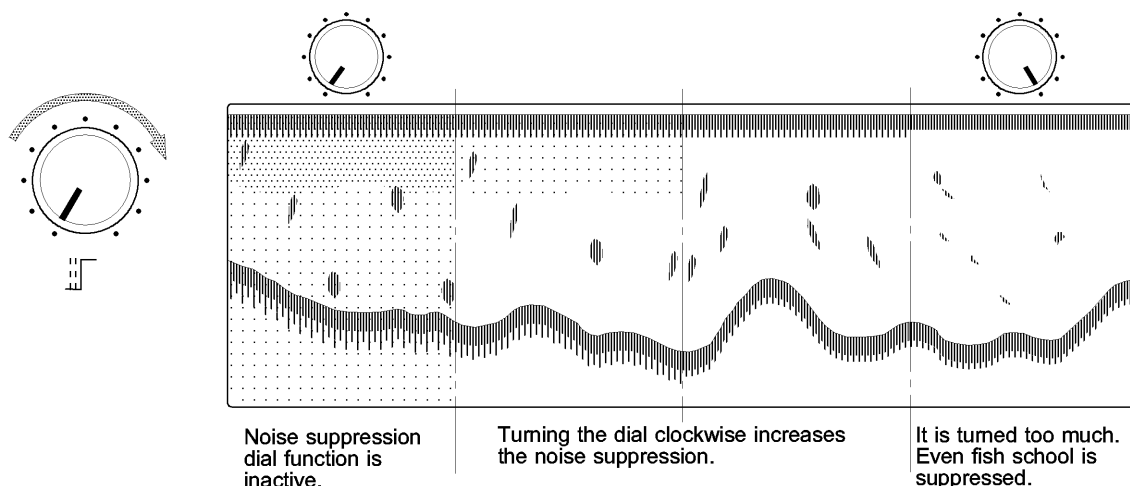

GAIN CONTROL DIALS

The level of sensitivity of the received echo signal.

Turning the dial clockwise increases the gain level, keep turning the dial until the sea bottom is shown in red.

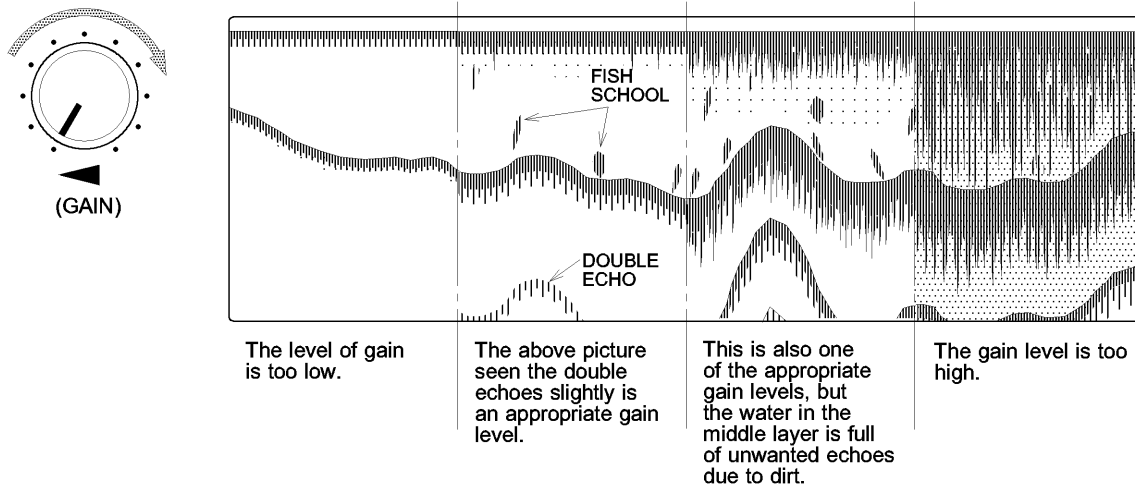

The strongest echoes are displayed in red and as the received echoes get weaker they are indicated as follows; red → orange → yellow → green → light green → blue → light blue (when color scale A1 or A2 is selected).

When the target is the sea bottom the gain level setting can be low because the echo from the sea bottom is very strong. However, when the target is fish the level of gain must be increased to pick up the weaker echo.

Increasing the gain too much will display unwanted echoes from bubbles and plankton etc.

If the sea bottom echo is weak due to seaweed, mud etc. adjust the gain level to pick up the weaker echo.

When passing over the transducer face, bubbles reflect the sound wave and appear as echoes on the screen. In this case, no echoes (fish school) may be displayed even though at a maximum gain level.

BRIGHTNESS CONTROL DIAL

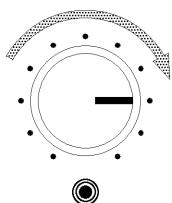

Further turning in a clockwise direction increases screen brightness.

Chapter 4

APPENDIX

This chapter provides you the explanation for the principle behind an echo sounder and the specifications.

WHAT IS AN ECHO SOUNDER ?

PRINCIPLE of ECHO SOUNDER	49
SOUNDER DISPLAY	49
TRANSDUCER CHARACTERISTICS	50
PRINCIPLE behind DISPLAY	51
HOW TO READ ECHO SOUNDER DISPLAY	52

CLEANING & DISPOSAL

53

SPECIFICATIONS

54

WHAT IS AN ECHO SOUNDER ?

PRINCIPLES of ECHO SOUNDER

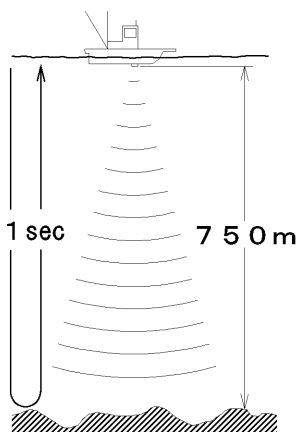

A device for measuring depth of water by sending pressure waves down from the surface and recording the time until the echo returns from the bottom.

By making full use of the properties of ultrasonic waves which travel at about 1500 m/sec, the depth can be measured. For example, when the echo returns in a second, the depth can be measured 750m .

The echo sounder displays this returned signal in some convenient form.

SOUNDER DISPLAY

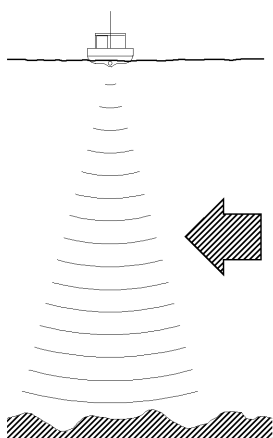

Data from the surface to the bottom is sectionally detected from the arrow side shown in the left drawing.

1) Being based on the principle that water is an excellent medium for the transmission of sound waves and will bounce off a reflecting layer travelling at about 1500m/sec., the reflection is detected by the transducer, amplified and transformed into a picture of a slice of the ocean which can be displayed on a LCD screen. This is a LCD echo sounder.

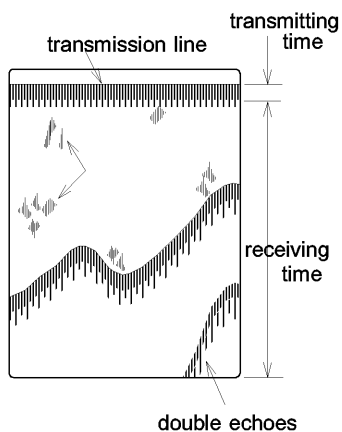

2) The time interval between the initiation of a sound pulse and echo returned from the bottom can be used to determine the depth of the bottom.

Transducer plays a role of receiving sensor and transmitting sensor and its receiving time is related to the depth range. The shallower the range, the less the returned time. The deeper the range, the more the returned time.

3) By making use of transmitting and receiving time to pick up the reflected echoes the display of fish school and the bottom can be seen on the screen.

Transducer (Ultra Sound Waves) Characteristics

1. 200kHz and 50kHz

The echo sounder in general uses either one or two transducers depending on whether it is a single frequency or dual frequency unit and is usually either 50kHz and or 200kHz.

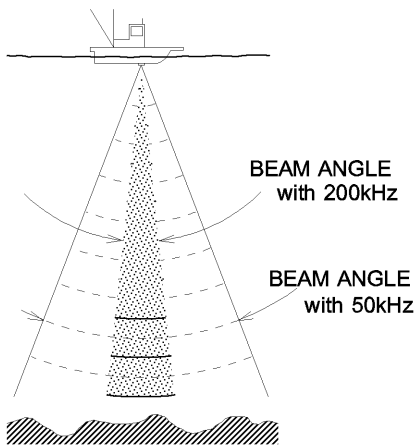

The ultrasonic pulse generated by an echo sounder can be aimed in a specific direction. The higher the frequency of the sound waves, the narrower the angle.

This angle is called beam angle.

	200kHz	50kHz
Beam angle	narrow (12°) *	wide (42°) *
Detection	shallow	deep
Resolution	good	bad
Air bubbles	less	more

Note : * shows the beam angles of the attached transducers for the ES-2035II.

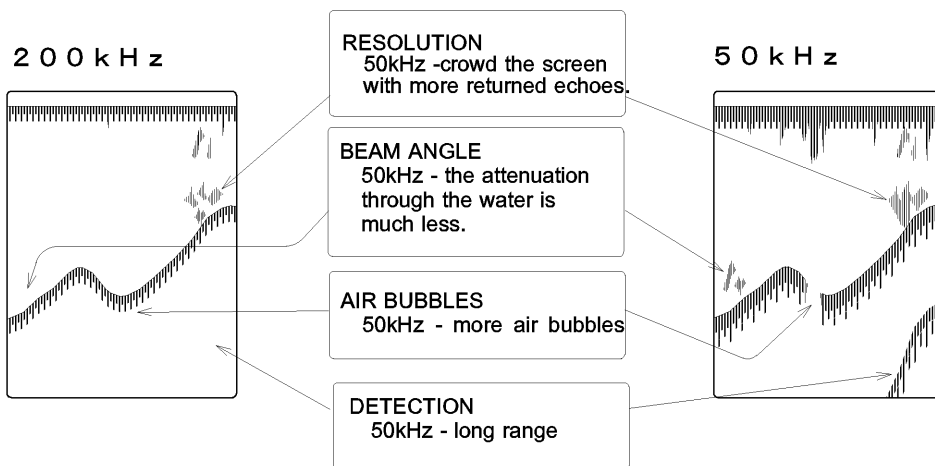

2. DETECTION RANGES

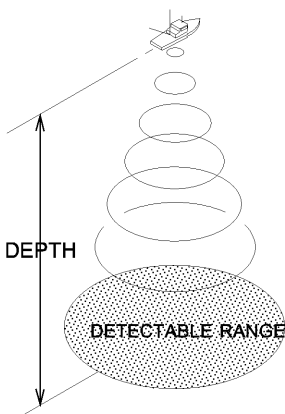

DEPTH	DETECTION RANGE	
	200kHz	50kHz
10m	2m	8m
20m	4m	15m
40m	8m	31m
60m	13m	46m
80m	17m	61m
100m	21m	77m

Lower frequencies tend to penetrate to greater depths than do higher frequencies.

Higher frequencies however tend to have a narrower beam angle than the lower frequency transducers.

The depth range of a 200kHz sounder is limited because the higher frequencies are attenuated by the water more than the lower frequencies, only objects directly beneath the boat can be seen.

The PRINCIPLE behind DISPLAY

This explains briefly by what principle the seabed, a shoal of fish, and a fish itself are served as record of the echo sounder.

1. REFLECTED ECHO FROM A FISH

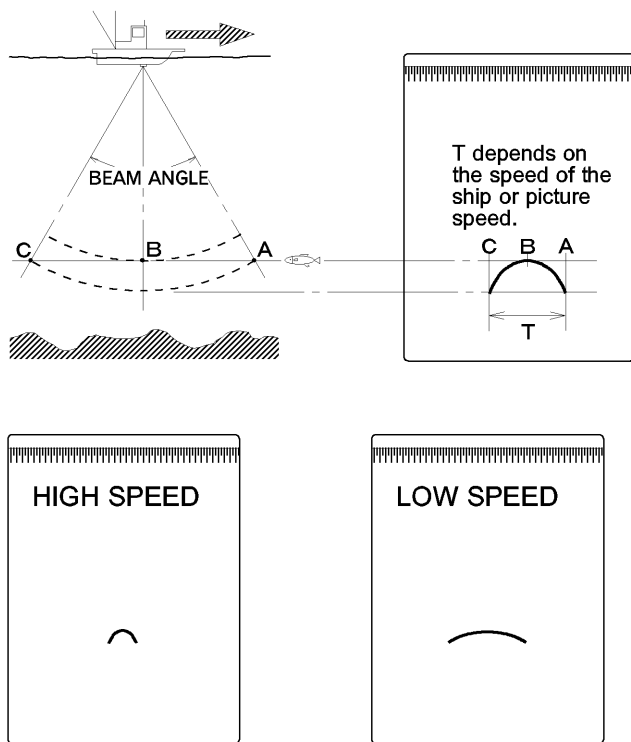

A crescent-like appears on the screen when passing through one fish (simple substance) at the low speed of the ship or in case of the wide beam angle.

For this, as shown in the figure, the displayed T width differs depending on the distance of the point A (C) or B and may become narrower at the high speed of the ship or in case of low picture speed.

The horizontal length of crescent-like displayed on the LCD screen differs depending on the speed of the ship or picture speed.

2. REFLECTED ECHO FROM THE SEABED

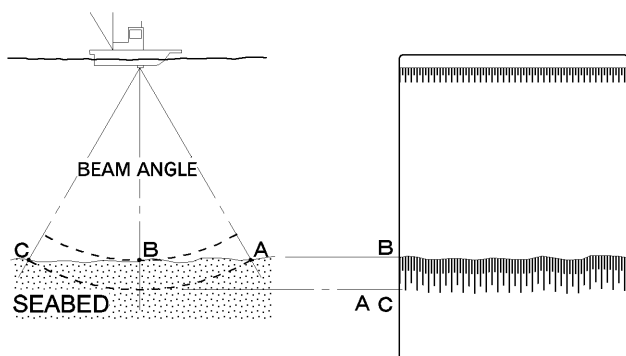

An ultrasonic wave spreads according to the beam angle, and is progress to the seabed.

Due to the longer distance of A and C they are served further than Point B as shown in the figure.

The hardness of the seabed can be loosely related to the depth or thickness of the seabed return sometimes referred to as the tail. The harder the seabed the thicker the seabed return, that is the depth from the top of the seabed echo to the bottom of the seabed echo.

On a very hard seabed there are a lot of strong reflections from the sides.

In areas of soft seabed very little echo returns from the sides and thus the seabed return does not appear as thick. Sometimes the double echoes are seen when the ultrasonic wave was rallied by reflecting the ship bottom or the sea surface again. In the shallow water the triple echoes are sometimes seen.

HOW TO READ ECHO SOUNDER DISPLAY

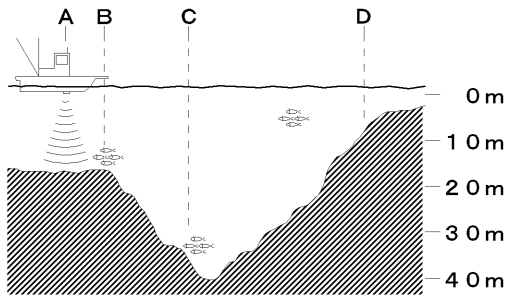

The reading procedure will be explained accordingly.

In a case that a ship advances to the direction of D point from A point, the power supply key is pressed at A point and the range of 0-50m was selected, following is a description of the way to read echo sounder display.

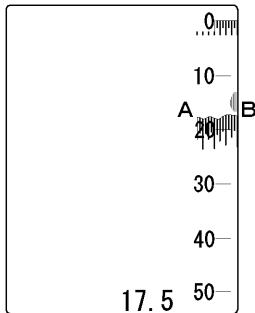

First reflections from the seabed between A and B points show up on the right side of the screen and its information is always a sound beam downward at a 90 degree angle, just below the ship.

The seabed depth is shown at the right bottom of the screen.

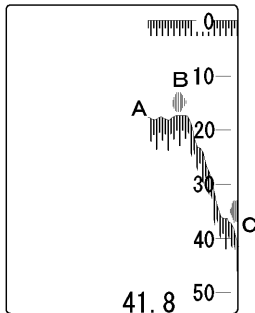

When the ship advanced to C point, the information between A and C points show up.

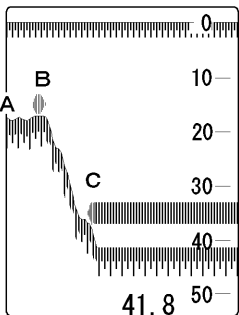

When the ship stops at C point, the flat seabed reflections are repeatedly presented on the screen.

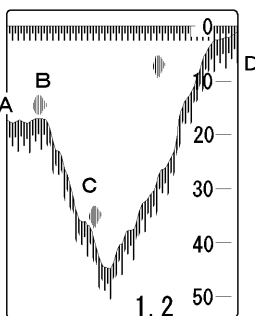

When the ship advanced to D point, the image appears like the left Fig. and the oldest information disappears at the left end of the screen.

CLEANING & DISPOSAL

CLEANING MAIN UNIT

Make sure to turn off the power before cleaning.

Do not use any chemical cleaners to clean the ES-2035II.

Wipe off dust or salt crystals from the filter lightly with a soft wet cloth.

Breathe out on the surface, and wipe off dust lightly with an absorbent cotton or clean soft cloth.

Using a dry or firm cloth may scratch the surface of LCD display. LCD display with many scratches shows the poor visibility of the screen.

If there is dust you cannot wipe away, contact your local dealer or SUZUKI head office.

DISPOSAL OF EQUIPMENT

Dispose of this equipment in accordance with local regulations.

DISPOSAL OF LITHIUM BATTERY

Before disposing of the lithium battery, place a piece of adhesive tape across the plus and minus terminals as non-combustible garbage.

Dispose of the lithium battery in accordance with local regulations.



This equipment contains the lithium battery of high-density energy.

Careless disposal of the lithium battery causes electric shorts, impact, heat, electrical shock, explosion, injury, fire and so on.

SPECIFICATIONS

1. DISPLAY RANGES: 0 ~ 5 · 10 · 15 · 20 · 30 · 40 · 50 · 60 · 80 · 100 · 150 · 200 · 300 · 500 · 1000 · 1500 · 2000 m, fm, br.
0 ~ 15 · 20 · 30 · 40 · 50 · 60 · 80 · 100 · 150 · 200 · 300 · 500 · 1000 · 1500 · 2000 · 3000 · 5000 ft.
2. PHASED RANGES: The upper range limit may be set per 2/5 of the range between 0 ~ 999 m, fm and br. from 0 ~ 2999 ft.
3. PARTIAL EXPANSION Available as a combination of the range and the phased range.
4. BOTTOM EXPANSION 0 ~ 1 · 2.5 · 5 · 10 · 20 · 50 · 100 · 250 m, fm, br.
0 ~ 5 · 10 · 20 · 50 · 100 · 250 · 500 · 1000 ft
5. FREQUENCY Single frequency unit : 50 or 200kHz
Dual frequency unit : 50 and 200kHz
6. DISPLAY MODES Single frequency unit : Normal mode · Bottom expansion mode · +A scope mode · Navigation/sounder display
Dual frequency unit : 50kHz Normal mode · 200kHz Normal mode · 50/200kHz dual frequency mode · small target mode
Bottom expansion mode · +A scope mode · Navigation/sounder display
7. DISPLAY DATA Depth scale · Depth (3 steps) · Water temp. (3 steps) *^{OP} · Water temp. scale *^{OP} · Marker line · Lat/Long *^{OP} · Ship's speed *^{OP} · Course *^{OP}
8. FUNCTION SET DISPLAY Alarm · Interference reduction · Picture speed · Auto range · Auto shift High/Low frequency
9. ADDITIONAL DISPLAY Second Interval Mark · Color scale · Water temp graph *^{OP} · Alarm makers Expansion range line · TX power
10. OTHER FUNCTIONS STC · Threshold · White line · Interference reduction · User setting · Noise suppression · Auto range · Auto shift · Data backup system Scale display position (2 positions) · Depth display position (2 positions) · Temp. display position (2 positions) · Expansion mode (4 modes) · Color selection (4 fixes + Color palette 2 user selection) · Depth scale grid TX power · Alarms (shallow/deep/fish) · Prior frequency of depth measurement · Picture speed (freeze & 4 steps)

Others

1. DISPLAY LCD (TFT) color, 10.4 inch (H640 x V480 pixels)
2. POWER SUPPLY 10.5-30VDC 25 Watts
3. INPUT Temp. sensor : OP-102 or OP-41 *^{OP}
Temp. data : NMEA-0183 (MTW) *^{OP}
Navigation data : NMEA-0183 (VTG · GGA · GLL · RMC) *^{OP}
4. OUTPUT NMEA-0183 (MTW · DBT)
5. WEIGHT 5 kg (bracket included)

NOTE: Functions marked with *^{OP} require optional equipment.